

TOSHIBA Transistor Silicon NPN Epitaxial Type (PCT Process)

# RN1207, RN1208, RN1209

Switching, Inverter Circuit, Interface Circuit  
And Driver Circuit Applications

Unit in mm

- With built-in bias resistors.
- Simplify circuit design
- Reduce a quantity of parts and manufacturing process
- Complementary to RN2207~2209

## Equivalent Circuit and Bias Resistor Values

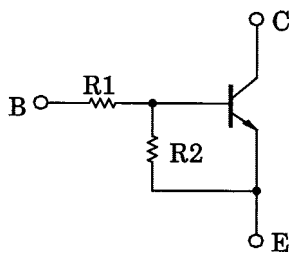

Type No.	R1 (kΩ)	R2 (kΩ)
RN2207	10	47
RN2208	22	47
RN2209	47	22

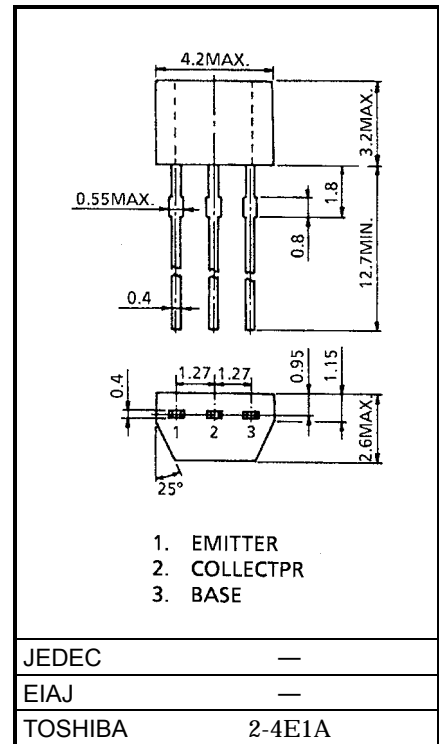

Weight: 0.13g

## Maximum Ratings (Ta = 25°C)

Characteristic	Symbol	Rating	Unit
Collector-base voltage	$V_{CBO}$	50	V
Collector-emitter voltage	$V_{CEO}$	50	V
Emitter-base voltage	$V_{EBO}$	RN1207	6
		RN1208	7
		RN1209	15
Collector current	$I_c$	100	mA
Collector power dissipation	$P_c$	300	mW
Junction temperature	$T_j$	150	°C
Storage temperature range	$T_{stg}$	-55~150	°C

961001EAA1

- TOSHIBA is continually working to improve the quality and the reliability of its products. Nevertheless, semiconductor devices in general can malfunction or fail due to their inherent electrical sensitivity and vulnerability to physical stress. It is the responsibility of the buyer, when utilizing TOSHIBA products, to observe standards of safety, and to avoid situations in which a malfunction or failure of a TOSHIBA product could cause loss of human life, bodily injury or damage to property. In developing your designs, please ensure that TOSHIBA products are used within specified operating ranges as set forth in the most recent products specifications. Also, please keep in mind the precautions and conditions set forth in the TOSHIBA Semiconductor Reliability Handbook.
- The information contained herein is presented only as a guide for the applications of our products. No responsibility is assumed by TOSHIBA CORPORATION for any infringements of intellectual property or other rights of the third parties which may result from its use. No license is granted by implication or otherwise under any intellectual property or other rights of TOSHIBA CORPORATION or others.
- The information contained herein is subject to change without notice.

**Electrical Characteristics (Ta = 25°C)**

Characteristic		Symbol	Test Circuit	Test Condition	Min	Typ.	Max	Unit
Collector cut-off current		$I_{CBO}$	—	$V_{CB} = 50V, I_E = 0$	—	—	100	nA
		$I_{CEO}$	—	$V_{CE} = 50V, I_B = 0$	—	—	500	nA
Emitter cut-off current	RN1207	$I_{EBO}$	—	$V_{EB} = 6V, I_C = 0$	0.081	—	0.15	mA
	RN1208		—	$V_{EB} = 7V, I_C = 0$	0.078	—	0.145	
	RN1209		—	$V_{EB} = 15V, I_C = 0$	0.167	—	0.311	
DC current gain	RN1207	$h_{FE}$	—	$V_{CE} = 5V, I_C = 10mA$	80	—	—	—
	RN1208		—		80	—	—	
	RN1209		—		70	—	—	
Collector-emitter saturation voltage		$V_{CE(sat)}$	—	$I_C = 5mA, I_B = 0.25mA$	—	0.1	0.3	V
Input voltage (ON)	RN1207	$V_{I(ON)}$	—	$V_{CE} = 0.2V, I_C = 5mA$	0.7	—	1.8	V
	RN1208		—		1.0	—	2.6	
	RN1209		—		2.2	—	5.8	
Input voltage (OFF)	RN1207	$V_{I(OFF)}$	—	$V_{CE} = 5V, I_C = 0.1mA$	0.5	—	1.0	V
	RN1208		—		0.6	—	1.16	
	RN1209		—		1.5	—	2.6	
Translation frequency		$f_T$	—	$V_{CE} = 10V, I_C = 5mA$	—	250	—	MHz
Collector output capacitance		$C_{ob}$	—	$V_{CB} = 10V, I_E = 0, f = 1MHz$	—	3	6	pF
Input resistor	RN1207	R1	—	—	7	10	13	kΩ
	RN1208		—		15.4	22	28.6	
	RN1209		—		32.9	47	61.1	
Resistor Ratio	RN1207	R1/R2	—	—	0.191	0.213	0.232	—
	RN1208		—		0.421	0.468	0.515	
	RN1209		—		1.92	2.14	2.35	

