

# TOSHIBA RN1221,RN1222,RN1223,RN1224,RN1225,RN1226,RN1227

TOSHIBA Transistor Silicon NPN Epitaxial Type (PCT Process)

## RN1221,RN1222,RN1223,RN1224 RN1225,RN1226,RN1227

Switching, Inverter Circuit, Interface Circuit  
And Driver Circuit Applications

Unit in mm

- High current type ( $I_{C(MAX)} = 800\text{mA}$ )
- With built-in bias resistors.
- Simplify circuit design
- Reduce a quantity of parts and manufacturing process
- Low  $V_{CE(sat)}$
- Complementary to RN2221~2227

### Equivalent Circuit

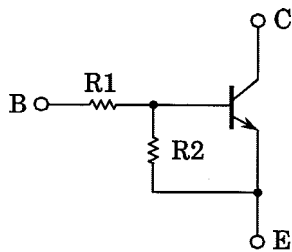

| Type No. | R1 (k $\Omega$ ) | R2 (k $\Omega$ ) |
|----------|------------------|------------------|
| RN1221   | 1                | 1                |
| RN1222   | 2.2              | 2.2              |
| RN1223   | 4.7              | 4.7              |
| RN1224   | 10               | 10               |
| RN1225   | 0.47             | 10               |
| RN1226   | 1                | 10               |
| RN1227   | 2.2              | 10               |

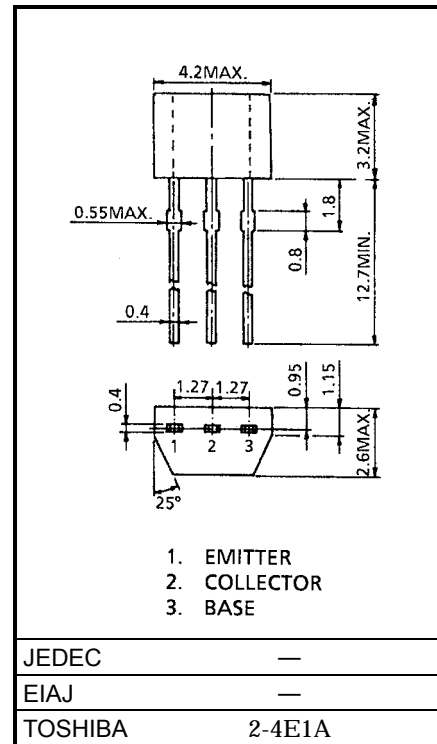

Weight: 0.13g

### Maximum Ratings ( $T_a = 25^\circ\text{C}$ )

| Characteristic              |              | Symbol    | Rating  | Unit             |
|-----------------------------|--------------|-----------|---------|------------------|
| Collector-base voltage      | RN1221~1227  | $V_{CBO}$ | 50      | V                |
| Collector-emitter voltage   |              | $V_{CEO}$ | 50      | V                |
| Emitter-base voltage        | RN1221~1224  | $V_{EBO}$ | 10      | V                |
|                             | RN1225, 1226 |           | 5       |                  |
|                             | RN1227       |           | 6       |                  |
| Collector current           | RN1221~1227  | $I_c$     | 800     | mA               |
| Collector power dissipation |              | $P_C$     | 300     | mW               |
| Junction temperature        |              | $T_j$     | 150     | $^\circ\text{C}$ |
| Storage temperature range   |              | $T_{stg}$ | -55~150 | $^\circ\text{C}$ |

961001EAA2

- TOSHIBA is continually working to improve the quality and the reliability of its products. Nevertheless, semiconductor devices in general can malfunction or fail due to their inherent electrical sensitivity and vulnerability to physical stress. It is the responsibility of the buyer, when utilizing TOSHIBA products, to observe standards of safety, and to avoid situations in which a malfunction or failure of a TOSHIBA product could cause loss of human life, bodily injury or damage to property. In developing your designs, please ensure that TOSHIBA products are used within specified operating ranges as set forth in the most recent products specifications. Also, please keep in mind the precautions and conditions set forth in the TOSHIBA Semiconductor Reliability Handbook.
- The information contained herein is presented only as a guide for the applications of our products. No responsibility is assumed by TOSHIBA CORPORATION for any infringements of intellectual property or other rights of the third parties which may result from its use. No license is granted by implication or otherwise under any intellectual property or other rights of TOSHIBA CORPORATION or others.
- The information contained herein is subject to change without notice.

**Electrical Characteristics (Ta = 25°C)**

| Characteristic                       |              | Symbol        | Test Circuit | Test Condition                    | Min                    | Typ.  | Max   | Unit |
|--------------------------------------|--------------|---------------|--------------|-----------------------------------|------------------------|-------|-------|------|
| Collector cut-off current            | RN1221~1227  | $I_{CBO}$     | —            | $V_{CB} = 50V, I_E = 0$           | —                      | —     | 100   | nA   |
|                                      |              | $I_{CEO}$     | —            | $V_{CE} = 50V, I_B = 0$           | —                      | —     | 500   |      |
| Emitter cut-off current              | RN1221       | $I_{EBO}$     | —            | $V_{EB} = 10V, I_C = 0$           | 3.85                   | —     | 7.14  | mA   |
|                                      | RN1222       |               | —            |                                   | 1.75                   | —     | 3.25  |      |
|                                      | RN1223       |               | —            |                                   | 0.82                   | —     | 1.52  |      |
|                                      | RN1224       |               | —            | $V_{EB} = 5V, I_C = 0$            | 0.38                   | —     | 0.71  |      |
|                                      | RN1225       |               | —            |                                   | 0.365                  | —     | 0.682 |      |
|                                      | RN1226       |               | —            |                                   | 0.35                   | —     | 0.65  |      |
|                                      | RN1227       |               | —            |                                   | $V_{EB} = 6V, I_C = 0$ | 0.378 | —     |      |
| DC current gain                      | RN1221       | $h_{FE}$      | —            | $V_{CE} = 5V, I_C = 100mA$        | 60                     | —     | —     | —    |
|                                      | RN1222       |               | —            |                                   | 65                     | —     | —     |      |
|                                      | RN1223       |               | —            |                                   | 70                     | —     | —     |      |
|                                      | RN1224       |               | —            |                                   | 90                     | —     | —     |      |
|                                      | RN1225       |               | —            |                                   | 90                     | —     | —     |      |
|                                      | RN1226       |               | —            |                                   | 90                     | —     | —     |      |
|                                      | RN1227       |               | —            |                                   | 90                     | —     | —     |      |
| Collector-emitter saturation voltage | RN1221       | $V_{CE(sat)}$ | —            | $I_C = 50mA, I_B = 2mA$           | —                      | —     | 0.25  | V    |
|                                      | RN1222~1227  |               | —            | $I_C = 50mA, I_B = 1mA$           | —                      | —     |       |      |
| Input voltage (ON)                   | RN1221       | $V_I(ON)$     | —            | $V_{CE} = 0.2V, I_C = 100mA$      | 1.0                    | —     | 3.5   | V    |
|                                      | RN1222       |               | —            |                                   | 1.4                    | —     | 4.5   |      |
|                                      | RN1223       |               | —            |                                   | 2.0                    | —     | 6.5   |      |
|                                      | RN1224       |               | —            |                                   | 3.0                    | —     | 12.0  |      |
|                                      | RN1225       |               | —            |                                   | 0.6                    | —     | 2.0   |      |
|                                      | RN1226       |               | —            |                                   | 0.7                    | —     | 2.5   |      |
|                                      | RN1227       |               | —            |                                   | 1.0                    | —     | 3.0   |      |
| Input voltage (OFF)                  | RN1221~1224  | $V_I(OFF)$    | —            | $V_{CE} = 5V, I_C = 0.1mA$        | 0.8                    | —     | 1.3   | V    |
|                                      | RN1225, 1226 |               | —            |                                   | 0.4                    | —     | 0.8   |      |
|                                      | RN1227       |               | —            |                                   | 0.5                    | —     | 1.0   |      |
| Transition frequency                 | RN1221~1227  | $f_T$         | —            | $V_{CE} = 5V, I_C = 20mA$         | —                      | 300   | —     | MHz  |
| Collector output capacitance         | RN1221~1227  | $C_{ob}$      | —            | $V_{CB} = 10V, I_E = 0, f = 1MHz$ | —                      | 7     | —     | pF   |

**Electrical Characteristics (Ta = 25°C)**

| Characteristic |             | Symbol | Test Circuit | Test Condition | Min    | Typ.  | Max    | Unit |
|----------------|-------------|--------|--------------|----------------|--------|-------|--------|------|
| Input resistor | RN1221      | R1     | —            | —              | 0.7    | 1.0   | 1.3    | kΩ   |
|                | RN1222      |        | —            |                | 1.54   | 2.2   | 2.86   |      |
|                | RN1223      |        | —            |                | 3.29   | 4.7   | 6.11   |      |
|                | RN1224      |        | —            |                | 7      | 10    | 13     |      |
|                | RN1225      |        | —            |                | 0.329  | 0.47  | 0.61   |      |
|                | RN1226      |        | —            |                | 0.7    | 1.0   | 1.3    |      |
|                | RN1227      |        | —            |                | 1.54   | 2.2   | 2.86   |      |
| Resistor ratio | RN1221~1224 | R1/R2  | —            | —              | 0.9    | 1.0   | 1.1    | —    |
|                | RN1225      |        | —            |                | 0.0423 | 0.047 | 0.0517 |      |
|                | RN1226      |        | —            |                | 0.09   | 0.1   | 0.11   |      |
|                | RN1227      |        | —            |                | 0.2    | 0.22  | 0.24   |      |

