

TOSHIBA Transistor Silicon NPN Epitaxial Type (PCT Process)

RN1307, RN1308, RN1309

Switching, Inverter Circuit, Interface Circuit
And Driver Circuit Applications

Unit in mm

- With built-in bias resistors.
- Simplify circuit design
- Reduce a quantity of parts and manufacturing process
- Complementary to RN2307~RN2309

Equivalent Circuit and Bias Resistor Values

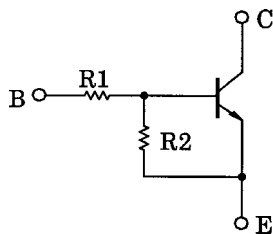

Type No.	R1 (kΩ)	R2 (kΩ)
RN2207	10	47
RN2208	22	47
RN2209	47	22

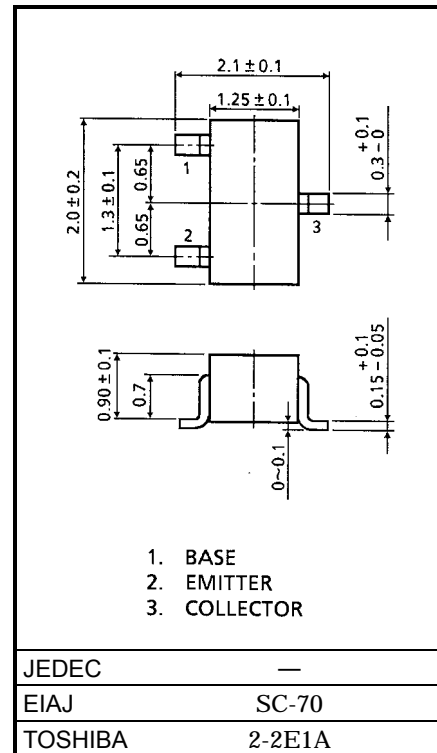

Weight: 0.006g

Maximum Ratings (Ta = 25°C)

Characteristic	Symbol	Rating	Unit
Collector-base voltage	V_{CBO}	50	V
Collector-emitter voltage	V_{CEO}	50	V
Emitter-base voltage	V_{EBO}	6	V
		7	
		15	
Collector current	I_c	100	mA
Collector power dissipation	P_c	100	mW
Junction temperature	T_j	150	°C
Storage temperature range	T_{stg}	-55~150	°C

961001EAA1

- TOSHIBA is continually working to improve the quality and the reliability of its products. Nevertheless, semiconductor devices in general can malfunction or fail due to their inherent electrical sensitivity and vulnerability to physical stress. It is the responsibility of the buyer, when utilizing TOSHIBA products, to observe standards of safety, and to avoid situations in which a malfunction or failure of a TOSHIBA product could cause loss of human life, bodily injury or damage to property. In developing your designs, please ensure that TOSHIBA products are used within specified operating ranges as set forth in the most recent products specifications. Also, please keep in mind the precautions and conditions set forth in the TOSHIBA Semiconductor Reliability Handbook.
- The information contained herein is presented only as a guide for the applications of our products. No responsibility is assumed by TOSHIBA CORPORATION for any infringements of intellectual property or other rights of the third parties which may result from its use. No license is granted by implication or otherwise under any intellectual property or other rights of TOSHIBA CORPORATION or others.
- The information contained herein is subject to change without notice.

Electrical Characteristics (Ta = 25°C)

Characteristic		Symbol	Test Circuit	Test Condition	Min	Typ.	Max	Unit
Collector cut-off current		I_{CBO}	—	$V_{CB} = 50V, I_E = 0$	—	—	100	nA
		I_{CEO}	—	$V_{CE} = 50V, I_B = 0$	—	—	500	
Emitter cut-off current	RN1307	I_{EBO}	—	$V_{EB} = 6V, I_C = 0$	0.081	—	0.15	mA
	RN1308		—	$V_{EB} = 7V, I_C = 0$	0.078	—	0.145	
	RN1309		—	$V_{EB} = 15V, I_C = 0$	0.167	—	0.311	
DC current gain	RN1307	h_{FE}	—	$V_{CE} = 5V, I_C = 10mA$	80	—	—	—
	RN1308		—		80	—	—	
	RN1309		—		70	—	—	
Collector-emitter saturation voltage		$V_{CE(sat)}$	—	$I_C = 5mA, I_B = 0.25mA$	—	0.1	0.3	V
Input voltage (ON)	RN1307	$V_{I(ON)}$	—	$V_{CE} = 0.2V, I_C = 5mA$	0.7	—	1.8	V
	RN1308		—		1.0	—	2.6	
	RN1309		—		2.2	—	5.8	
Input voltage (OFF)	RN1307	$V_{I(OFF)}$	—	$V_{CE} = 5V, I_C = 0.1mA$	0.5	—	1.0	V
	RN1308		—		0.6	—	1.16	
	RN1309		—		1.5	—	2.6	
Translation frequency		f_T	—	$V_{CE} = 10V, I_C = 5mA$	—	250	—	MHz
Collector output capacitance		C_{ob}	—	$V_{CB} = 10V, I_E = 0, f = 1MHz$	—	3	6	pF
Input resistor	RN1307	R1	—	—	7	10	13	kΩ
	RN1308		—		15.4	22	28.6	
	RN1309		—		32.9	47	61.1	
Resistor ratio	RN1307	R1/R2	—	—	0.191	0.213	0.232	—
	RN1308		—		0.421	0.468	0.515	
	RN1309		—		1.92	2.14	2.35	

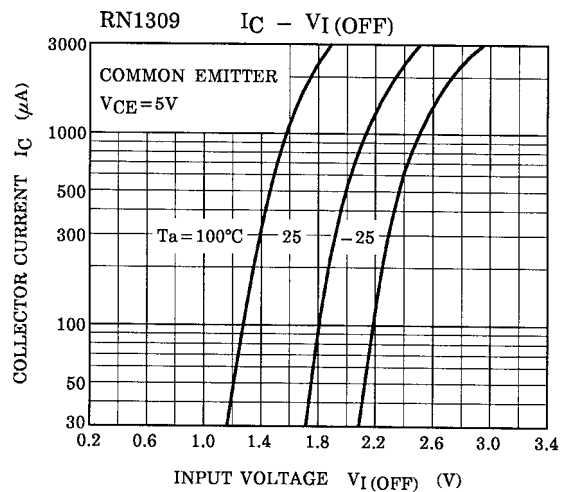
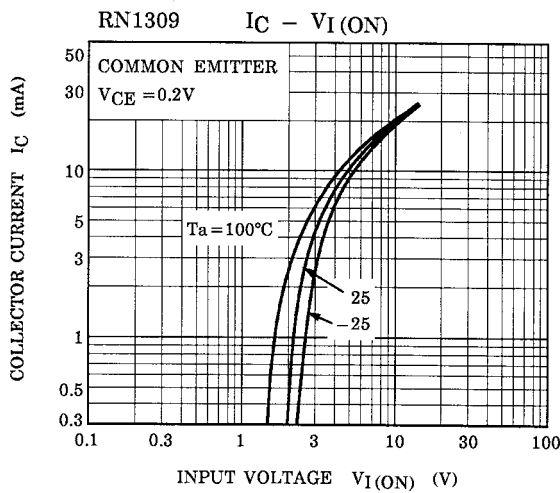
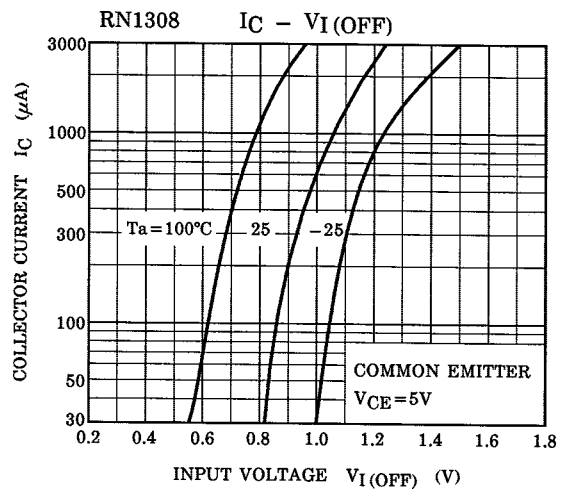
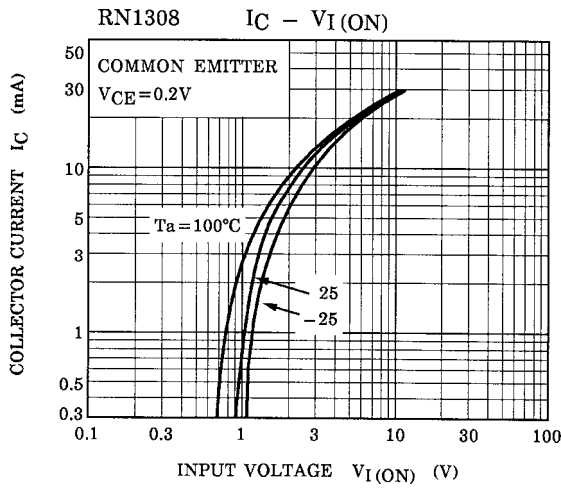
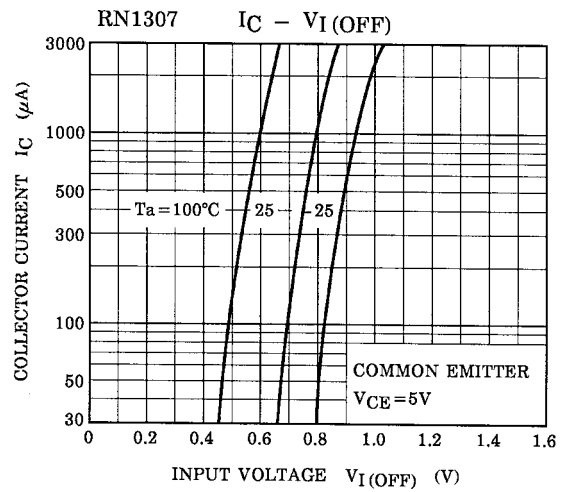
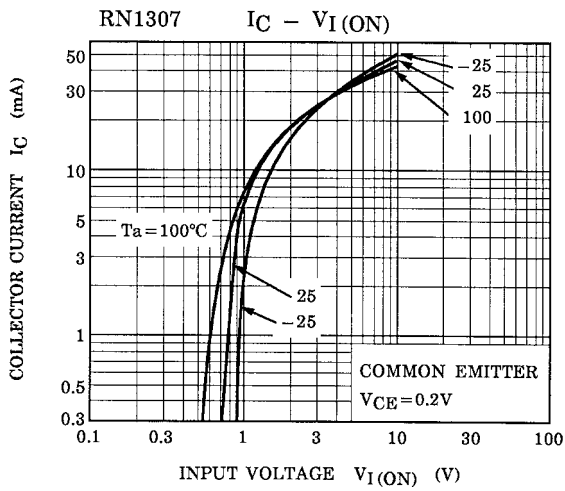

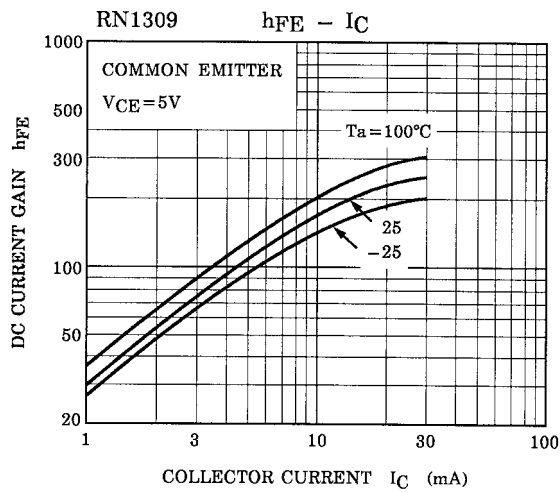
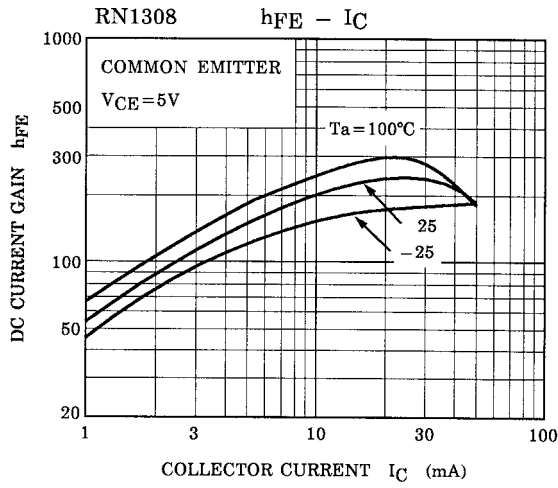
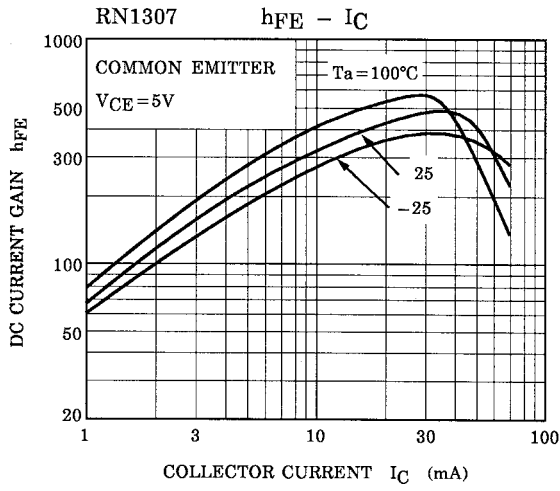

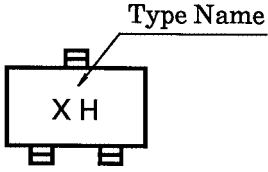
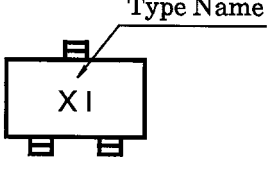
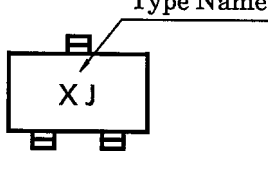
Type Name	Marking
RN1307	 <p>The diagram shows a rectangular component with a small square protrusion on top and two small rectangular protrusions at the bottom. The letters 'X H' are printed in the center. A line points from the text 'Type Name' to the top protrusion.</p>
RN1308	 <p>The diagram shows a rectangular component with a small square protrusion on top and two small rectangular protrusions at the bottom. The letters 'X I' are printed in the center. A line points from the text 'Type Name' to the top protrusion.</p>
Rn1309	 <p>The diagram shows a rectangular component with a small square protrusion on top and two small rectangular protrusions at the bottom. The letters 'X J' are printed in the center. A line points from the text 'Type Name' to the top protrusion.</p>