

TOSHIBA Transistor Silicon NPN Epitaxial Type (PCT Process)

RN1314, RN1315, RN1316 RN1317, RN1318

Switching, Inverter Circuit, Interface Circuit
And Driver Circuit Applications

- With built-in bias resistors
- Simplify circuit design
- Reduce a quantity of parts and manufacturing process
- Complementary to RN2314~RN2318

Equivalent Circuit and Bias Resister Values

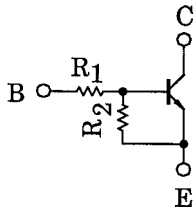

Type No.	R1 (kΩ)	R2 (kΩ)
RN1314	1	10
RN1315	2.2	10
RN1316	4.7	10
RN1317	10	4.7
RN1318	47	10

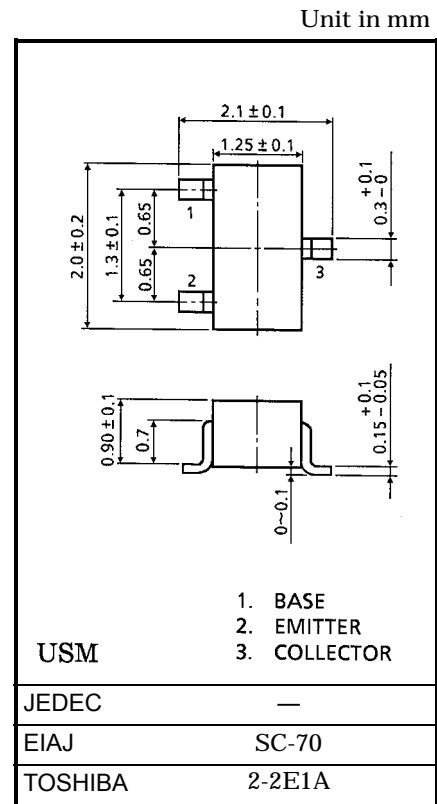

Weight: 0.006g

Maximum Ratings (Ta = 25°C)

Characteristic	Symbol	Rating	Unit	
Collector-base voltage	RN1314~1318	V _{CB0}	50	V
Collector-emitter voltage		V _{CEO}	50	V
Emitter-base voltage	RN1314~1318	V _{EBO}	5	V
			6	
			7	
			15	
			25	
Collector current	I _C	100	mA	
Collector power dissipation	P _C	100	mW	
Junction temperature	T _j	150	°C	
Storage temperature range	T _{stg}	-55~150	°C	

961001EAA2

- TOSHIBA is continually working to improve the quality and the reliability of its products. Nevertheless, semiconductor devices in general can malfunction or fail due to their inherent electrical sensitivity and vulnerability to physical stress. It is the responsibility of the buyer, when utilizing TOSHIBA products, to observe standards of safety, and to avoid situations in which a malfunction or failure of a TOSHIBA product could cause loss of human life, bodily injury or damage to property. In developing your designs, please ensure that TOSHIBA products are used within specified operating ranges as set forth in the most recent products specifications. Also, please keep in mind the precautions and conditions set forth in the TOSHIBA Semiconductor Reliability Handbook.
- The information contained herein is presented only as a guide for the applications of our products. No responsibility is assumed by TOSHIBA CORPORATION for any infringements of intellectual property or other rights of the third parties which may result from its use. No license is granted by implication or otherwise under any intellectual property or other rights of TOSHIBA CORPORATION or others.
- The information contained herein is subject to change without notice.

Electrical Characteristics (Ta = 25°C)

Characteristic		Symbol	Test Circuit	Test Condition	Min	Typ.	Max	Unit
Collector cut-off current	RN1314~1318	I_{CBO}	—	$V_{CB} = 50V, I_E = 0$	—	—	100	nA
	RN1314~1318	I_{CEO}		$V_{CE} = 50V, I_B = 0$	—	—	500	nA
Emitter cut-off current	RN1314	I_{EBO}	—	$V_{EB} = 5V, I_C = 0$	0.35	—	0.65	mA
	RN1315			$V_{EB} = 6V, I_C = 0$	0.37	—	0.71	
	RN1316			$V_{EB} = 7V, I_C = 0$	0.36	—	0.68	
	RN1317			$V_{EB} = 15V, I_C = 0$	0.78	—	1.46	
	RN1318			$V_{EB} = 25V, I_C = 0$	0.33	—	0.63	
DC current gain	RN1314~16,18	h_{FE}	—	$V_{CE} = 5V, I_C = 10mA$	50	—	—	
	RN1317				30	—	—	
Collector-emitter saturation voltage	RN1314~1318	$V_{CE(sat)}$	—	$I_C = 5mA, I_B = 0.25mA$	—	0.1	0.3	V
Input voltage (ON)	RN1314	$V_{I(ON)}$	—	$V_{CE} = 0.2V, I_C = 5mA$	0.6	—	2.0	V
	RN1315				0.7	—	2.5	
	RN1316				0.8	—	2.5	
	RN1317				1.5	—	3.5	
	RN1318				2.5	—	10.0	
Input voltage (OFF)	RN1314	$V_{I(OFF)}$	—	$V_{CE} = 5V, I_C = 0.1mA$	0.3	—	0.9	V
	RN1315				0.3	—	1.0	
	RN1316				0.3	—	1.1	
	RN1317				0.3	—	2.3	
	RN1318				0.5	—	5.7	
Transition frequency	RN1314~1318	f_T	—	$V_{CE} = 10V, I_C = 5mA$	—	250	—	MHz
Collector Output capacitance	RN1314~1318	C_{ob}	—	$V_{CB} = 10V, I_E = 0, f = 1MHz$	—	3.0	6.0	pF
Input resistor	RN1314	R_1	—	—	0.7	1.0	1.3	kΩ
	RN1315				1.54	2.2	2.86	
	RN1316				3.29	4.7	6.11	
	RN1317				7.0	10.0	13.0	
	RN1318				32.9	47.0	61.1	
Resistor ratio	RN1314	R_1/R_2	—	—	—	0.1	—	
	RN1315				—	0.22	—	
	RN1316				—	0.47	—	
	RN1317				—	2.13	—	
	RN1318				—	4.7	—	

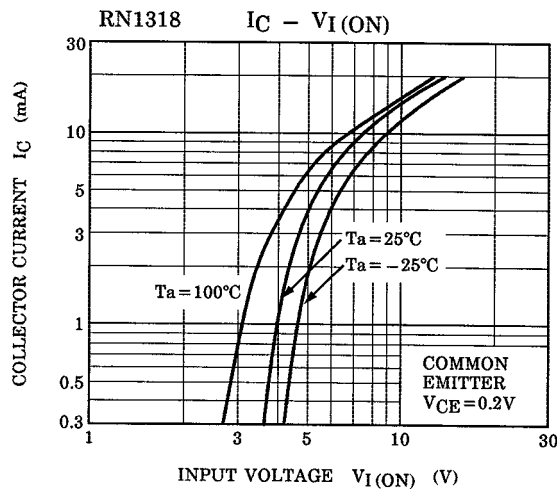
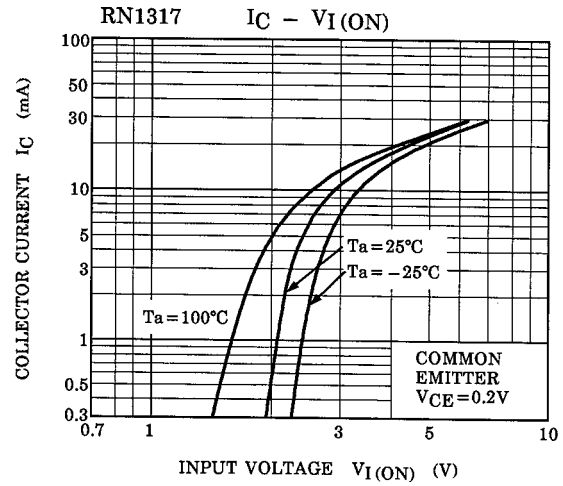
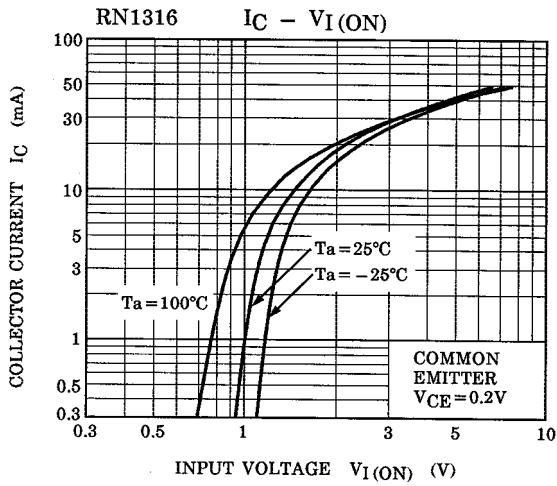
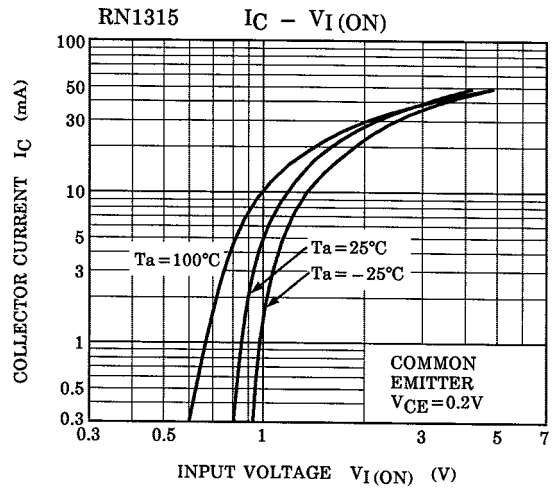
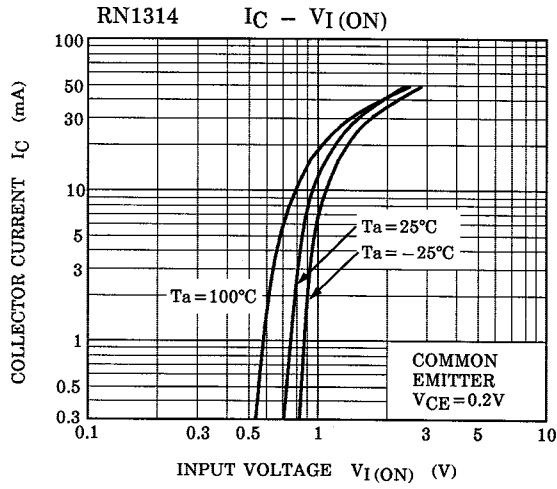

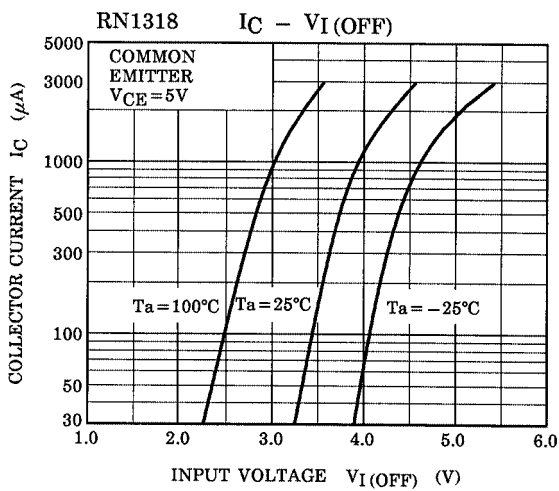
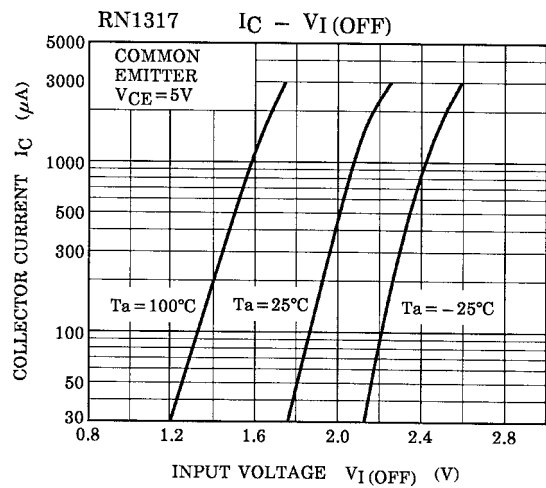
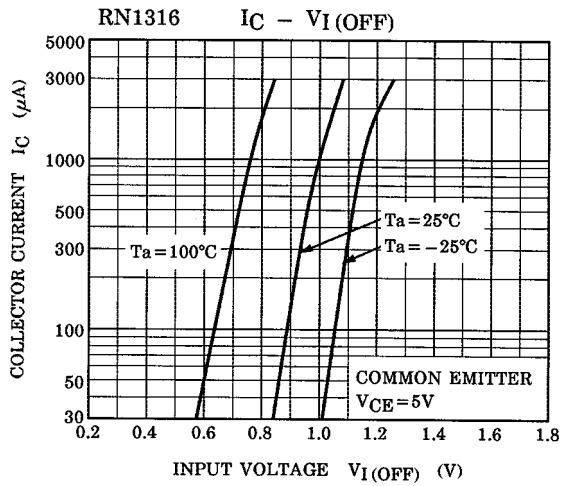
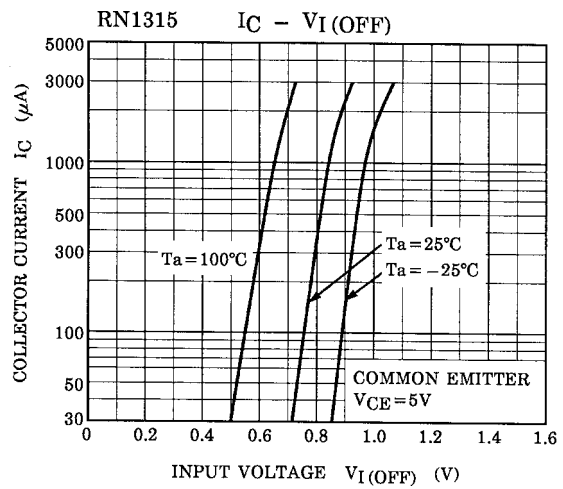
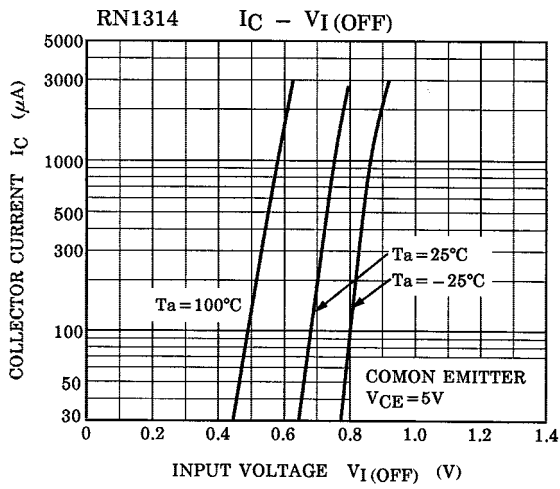

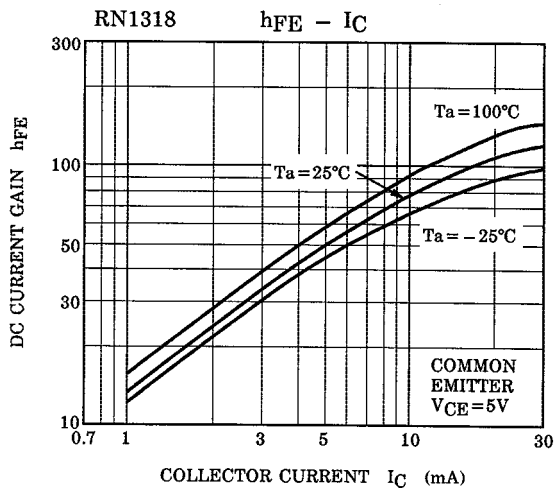
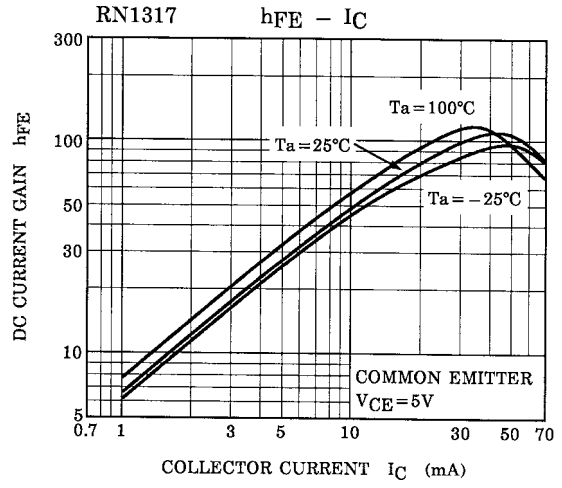
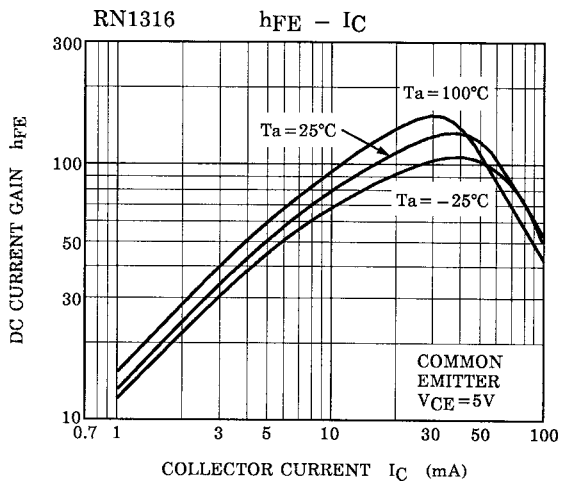
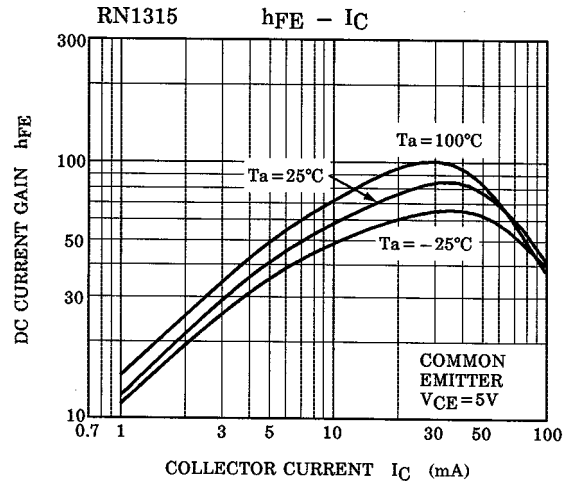
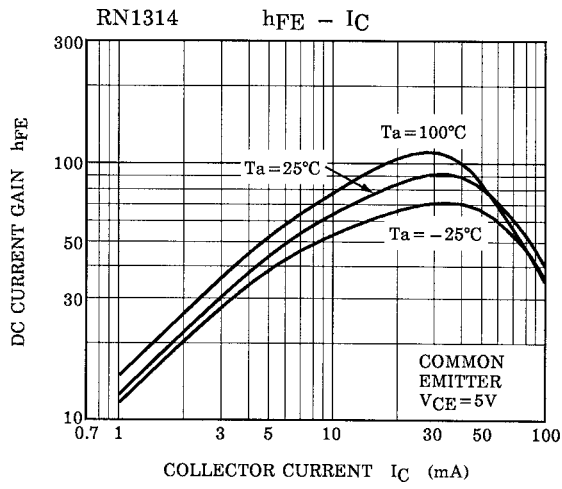

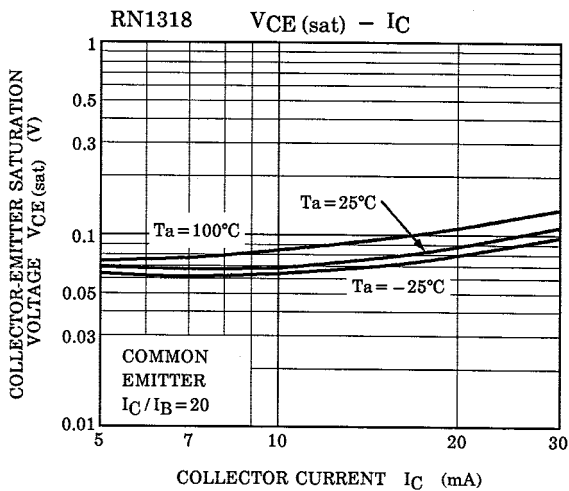
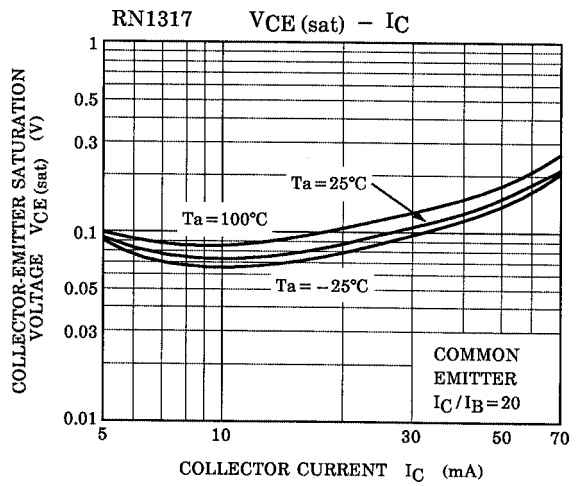
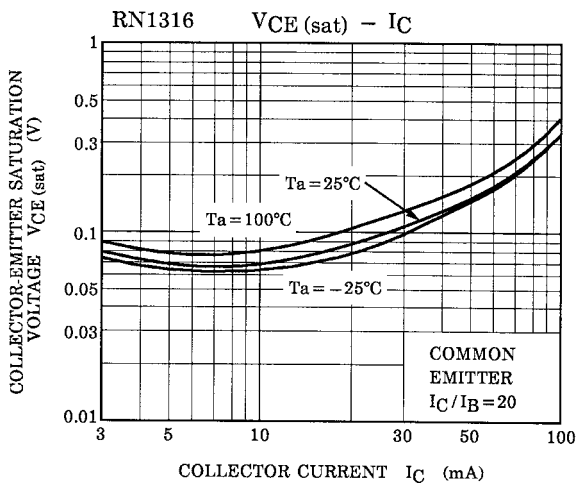
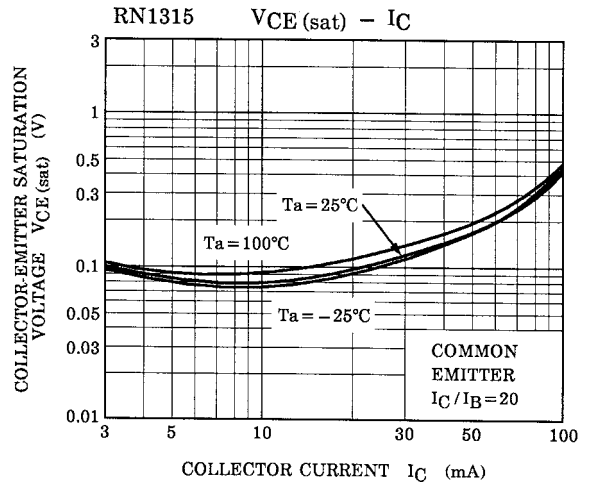
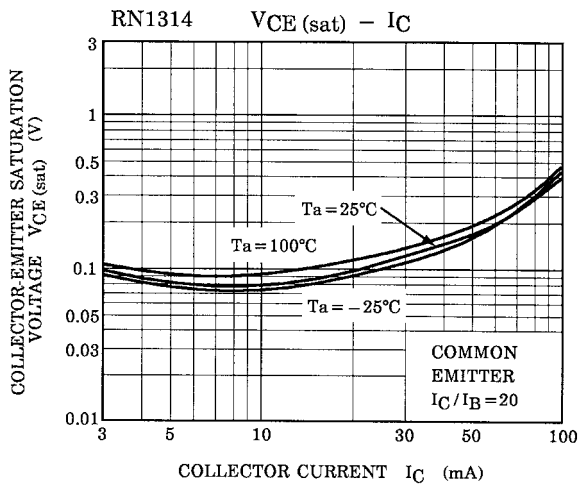

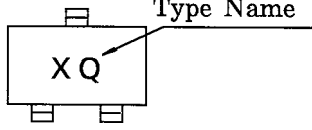
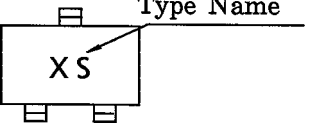
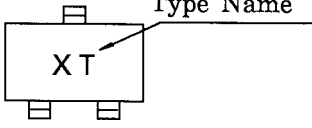
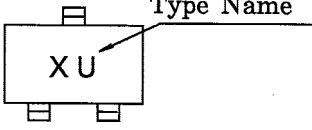
Type Name	Marking
RN1314	
RN1315	
RN1316	
RN1317	
RN1318	