

TOSHIBA Transistor Silicon NPN Epitaxial Type (PCT Process)

### RN1401, RN1402, RN1403 RN1404, RN1405, RN1406

Switching, Inverter Circuit, Interface Circuit  
And Driver Circuit Applications

- With built-in bias resistors
- Simplify circuit design
- Reduce a quantity of parts and manufacturing process
- Complementary to RN2401~RN2406

### Equivalent Circuit and Bias Resister Values

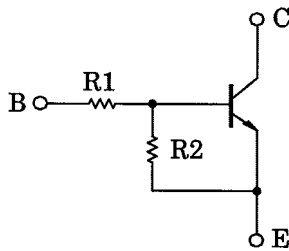

Type No.	R1 (kΩ)	R2 (kΩ)
RN1401	4.7	4.7
RN1402	10	10
RN1403	22	22
RN1404	47	47
RN1405	2.2	47
RN1406	4.7	47

Unit in mm

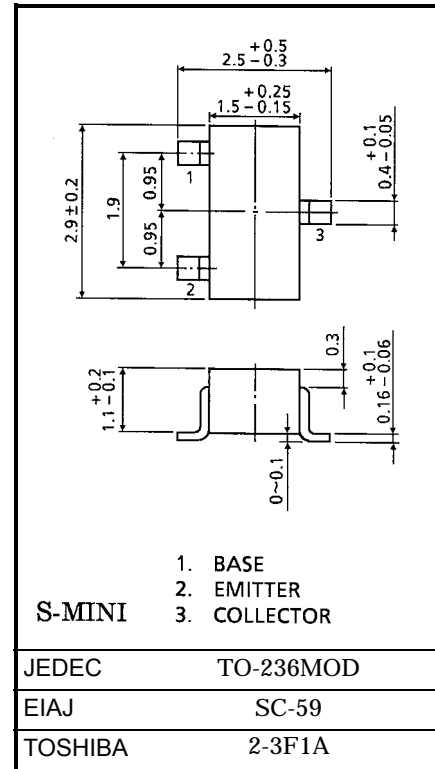

Weight: 0.012g

### Maximum Ratings (Ta = 25°C)

Characteristic	Symbol	Rating	Unit	
Collector-base voltage	RN1401~1406	$V_{CB0}$	50	V
Collector-emitter voltage		$V_{CEO}$	50	V
Emitter-base voltage	RN1401~1404	$V_{EBO}$	10	V
	RN1405, 1406		5	
Collector current	RN1401~1406	$I_C$	100	mA
Collector power dissipation		$P_C$	200	mW
Junction temperature		$T_j$	150	°C
Storage temperature range		$T_{stg}$	-55~150	°C

961001EAA2

- TOSHIBA is continually working to improve the quality and the reliability of its products. Nevertheless, semiconductor devices in general can malfunction or fail due to their inherent electrical sensitivity and vulnerability to physical stress. It is the responsibility of the buyer, when utilizing TOSHIBA products, to observe standards of safety, and to avoid situations in which a malfunction or failure of a TOSHIBA product could cause loss of human life, bodily injury or damage to property. In developing your designs, please ensure that TOSHIBA products are used within specified operating ranges as set forth in the most recent products specifications. Also, please keep in mind the precautions and conditions set forth in the TOSHIBA Semiconductor Reliability Handbook.
- The information contained herein is presented only as a guide for the applications of our products. No responsibility is assumed by TOSHIBA CORPORATION for any infringements of intellectual property or other rights of the third parties which may result from its use. No license is granted by implication or otherwise under any intellectual property or other rights of TOSHIBA CORPORATION or others.
- The information contained herein is subject to change without notice.

**Electrical Characteristics (Ta = 25°C)**

Characteristic		Symbol	Test Circuit	Test Condition	Min	Typ.	Max	Unit
Collector cut-off current	RN1401~1406	$I_{CBO}$	—	$V_{CB} = 50V, I_E = 0$	—	—	100	nA
		$I_{CEO}$		$V_{CE} = 50V, I_B = 0$	—	—	500	
Emitter cut-off current	RN1401	$I_{EBO}$	—	$V_{EB} = 10V, I_C = 0$	0.82	—	1.52	mA
	RN1402				0.38	—	0.71	
	RN1403				0.17	—	0.33	
	RN1404			0.082	—	0.15		
	RN1405			$V_{EB} = 5V, I_C = 0$	0.078	—	0.145	
	RN1406				0.074	—	0.138	
DC current gain	RN1401	$h_{FE}$	—	$V_{CE} = 5V, I_C = 10mA$	30	—	—	—
	RN1402				50	—	—	
	RN1403				70	—	—	
	RN1404				80	—	—	
	RN1405				80	—	—	
	RN1406				80	—	—	
Collector-emitter saturation voltage	RN1401~1406	$V_{CE(sat)}$	—	$I_C = 5mA, I_B = 0.25mA$	—	0.1	0.3	V
Input voltage (ON)	RN1401	$V_{I(ON)}$	—	$V_{CE} = 0.2V, I_C = 5mA$	1.1	—	2.0	V
	RN1402				1.2	—	2.4	
	RN1403				1.3	—	3.0	
	RN1404				1.5	—	5.0	
	RN1405				0.6	—	1.1	
	RN1406				0.7	—	1.3	
Input voltage (OFF)	RN1401~1404	$V_{I(OFF)}$	—	$V_{CE} = 5V, I_C = 0.1mA$	1.0	—	1.5	V
	RN1405, 1406				0.5	—	0.8	
Transition frequency	RN1401~1406	$f_T$	—	$V_{CE} = 10V, I_C = 5mA$	—	250	—	MHz
Collector Output capacitance	RN1401~1406	$C_{ob}$	—	$V_{CB} = 10V, I_E = 0, f = 1MHz$	—	3	6	pF
Input resistor	RN1401	R1	—	—	3.29	4.7	6.11	kΩ
	RN1402				7	10	13	
	RN1403				15.4	22	28.6	
	RN1404				32.9	47	61.1	
	RN1405				1.54	2.2	2.86	
	RN1406				3.29	4.7	6.11	
Resistor ratio	RN1401~1404	R1/R2	—	—	0.9	1.0	1.1	—
	RN1405				0.0421	0.0468	0.0515	
	RN1406				0.09	0.1	0.11	

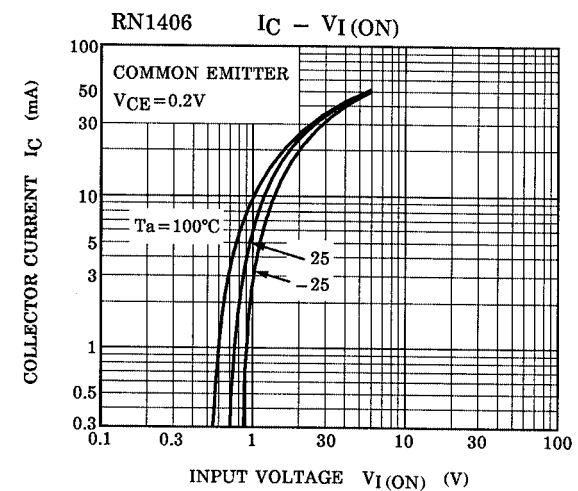
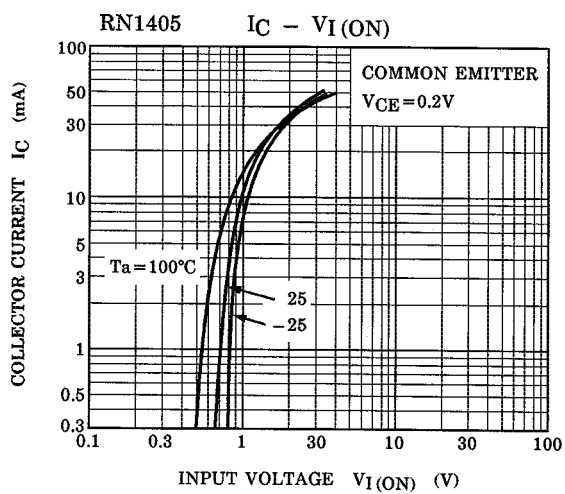
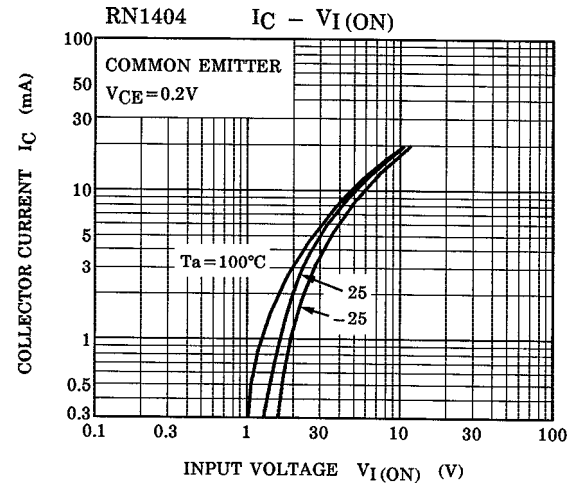
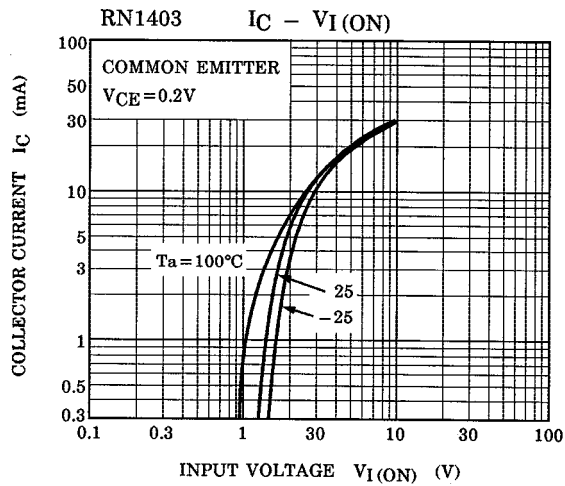
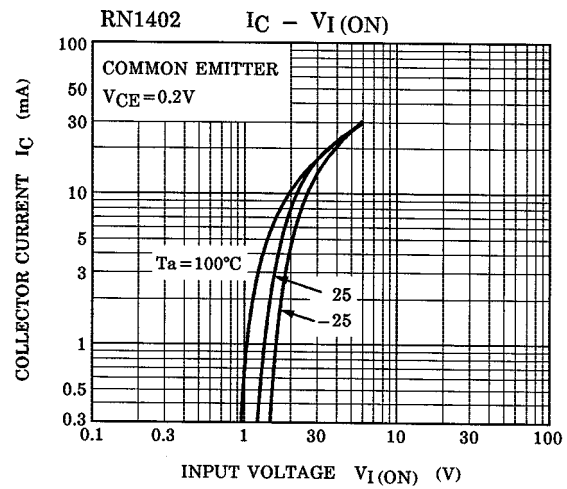
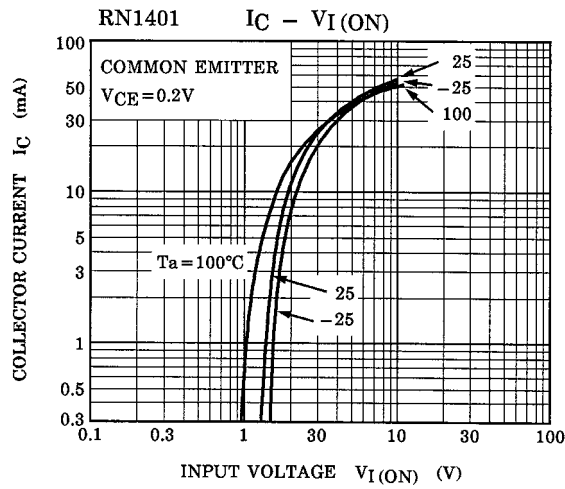

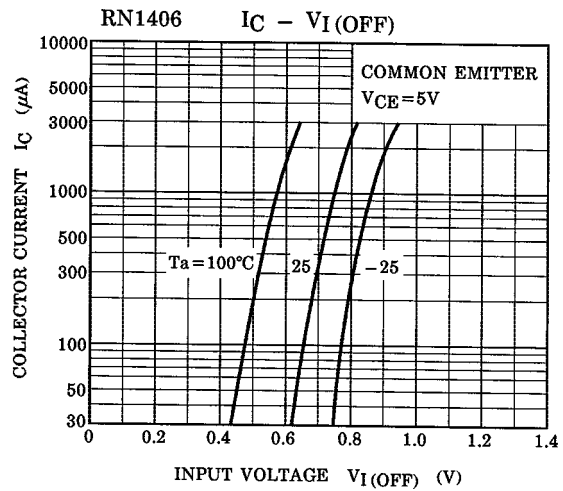
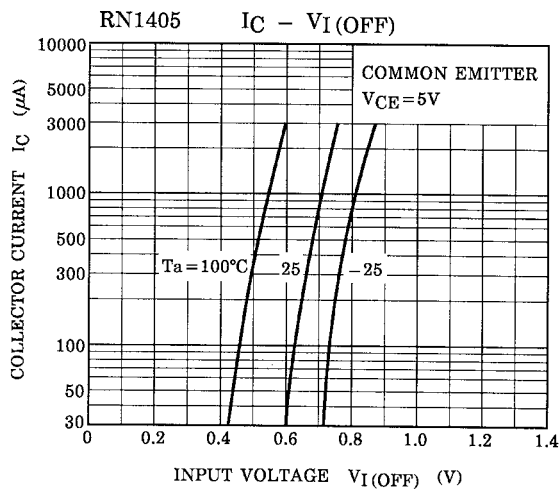
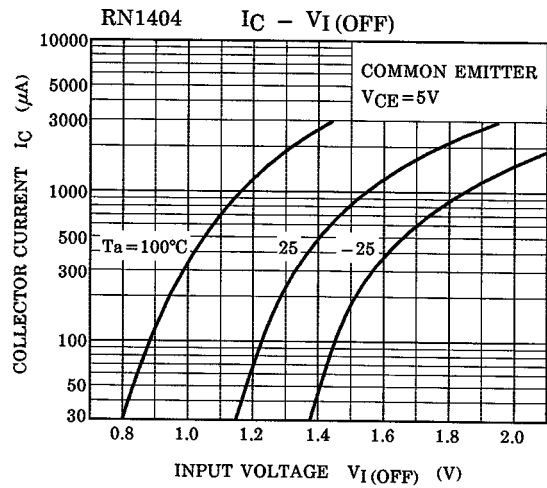
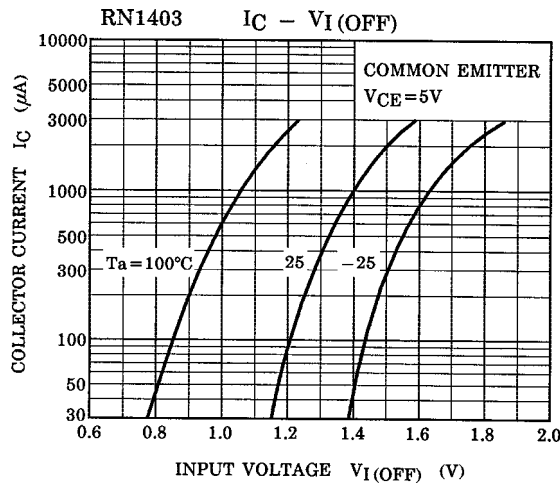
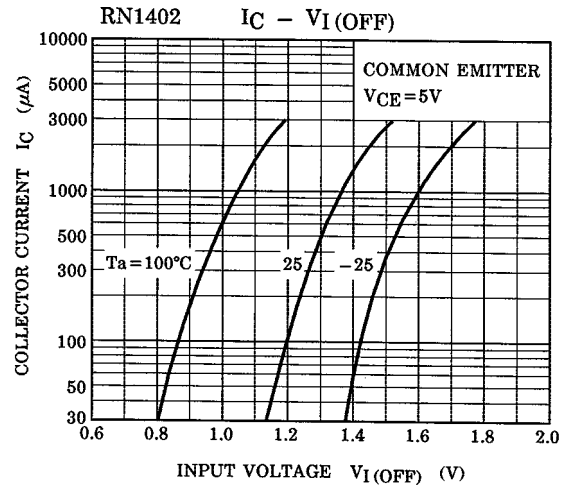
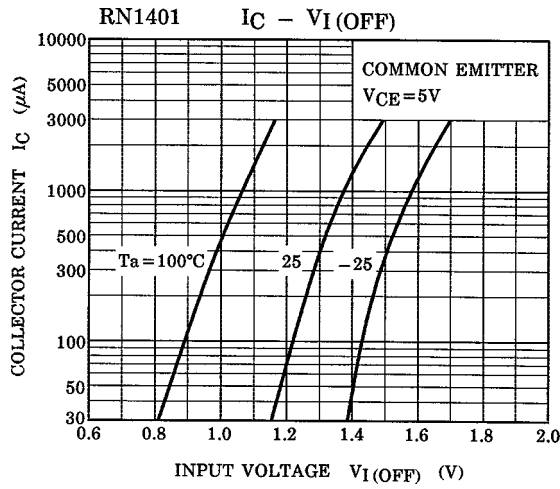

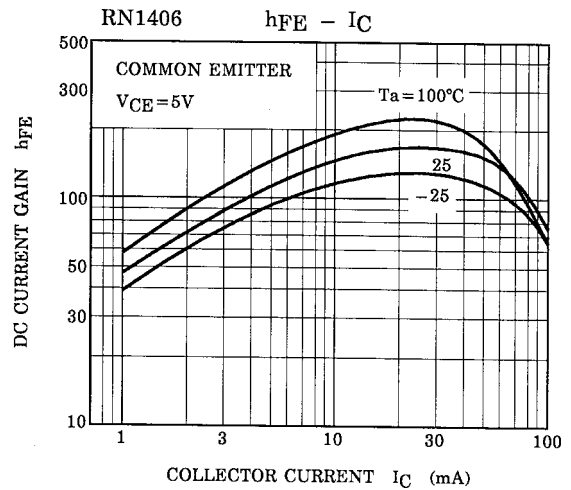
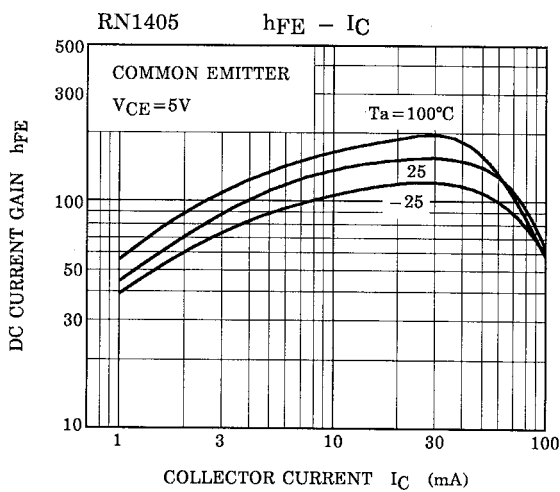
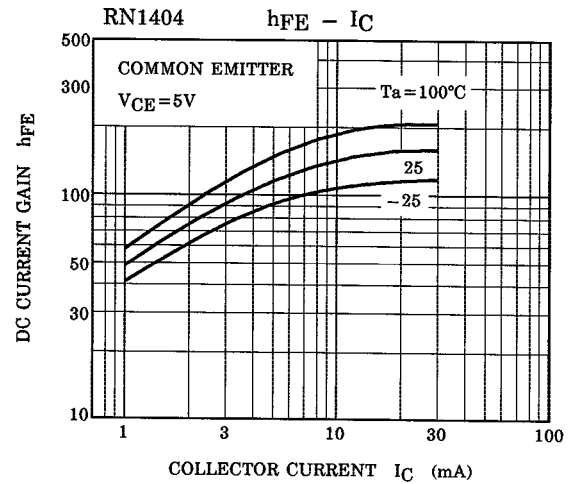
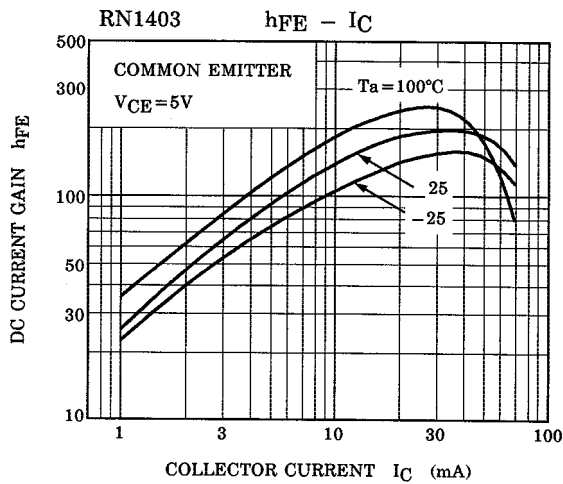
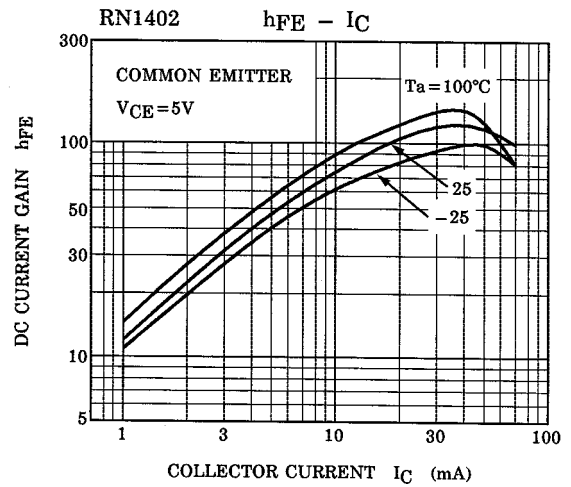
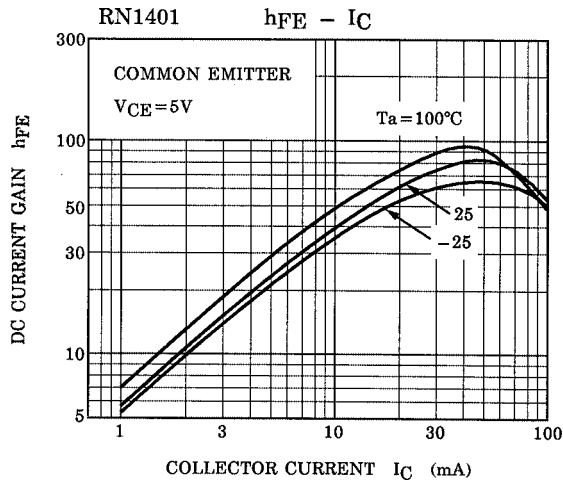

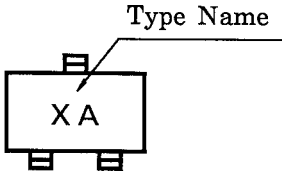
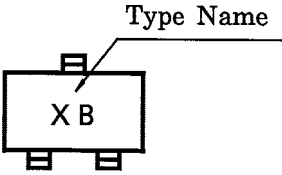
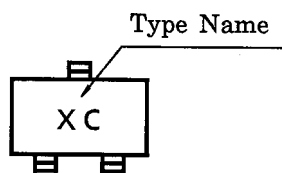
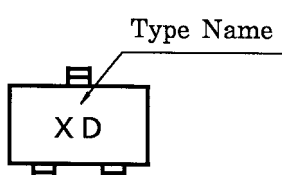
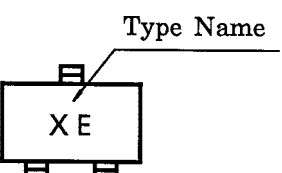
Type Name	Marking
RN1401	
RN1402	
RN1403	
RN1404	
RN1405	
RN1406	