

TOSHIBA Transistor Silicon NPN Epitaxial Type (PCT Process)

# RN1407,RN1408,RN1409

Switching, Inverter Circuit, Interface Circuit  
And Driver Circuit Applications

- With built-in bias resistors
- Simplify circuit design
- Reduce a quantity of parts and manufacturing process
- Complementary to RN2407~RN2409

## Equivalent Circuit and Bias Resister Values

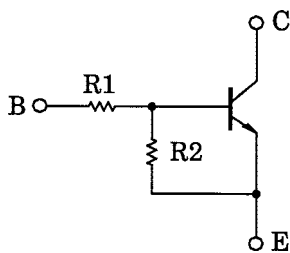

Type No.	R1 (kΩ)	R2 (kΩ)
RN1407	10	47
RN1408	22	47
RN1409	47	22

Unit in mm

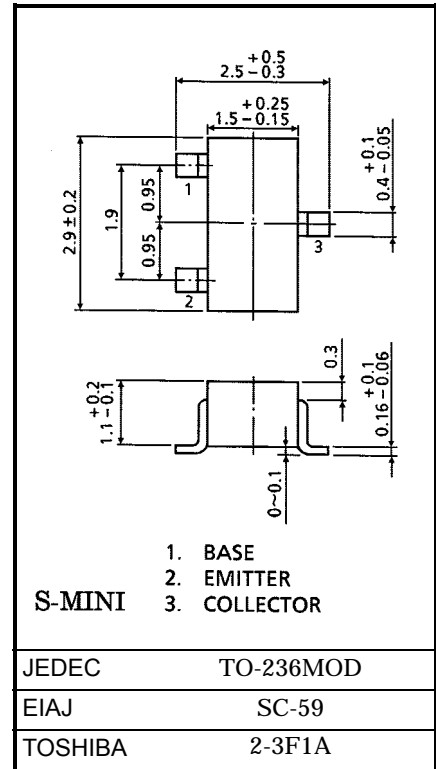

Weight: 0.012g

## Maximum Ratings (Ta = 25°C)

Characteristic	Symbol	Rating	Unit
Collector-base voltage	$V_{CBO}$	50	V
Collector-emitter voltage	$V_{CEO}$	50	V
Emitter-base voltage	$V_{EBO}$	6	V
		7	
		15	
Collector current	$I_C$	100	mA
Collector power dissipation	$P_C$	200	mW
Junction temperature	$T_j$	150	°C
Storage temperature range	$T_{stg}$	-55~150	°C

961001EAA2

- TOSHIBA is continually working to improve the quality and the reliability of its products. Nevertheless, semiconductor devices in general can malfunction or fail due to their inherent electrical sensitivity and vulnerability to physical stress. It is the responsibility of the buyer, when utilizing TOSHIBA products, to observe standards of safety, and to avoid situations in which a malfunction or failure of a TOSHIBA product could cause loss of human life, bodily injury or damage to property. In developing your designs, please ensure that TOSHIBA products are used within specified operating ranges as set forth in the most recent products specifications. Also, please keep in mind the precautions and conditions set forth in the TOSHIBA Semiconductor Reliability Handbook.
- The information contained herein is presented only as a guide for the applications of our products. No responsibility is assumed by TOSHIBA CORPORATION for any infringements of intellectual property or other rights of the third parties which may result from its use. No license is granted by implication or otherwise under any intellectual property or other rights of TOSHIBA CORPORATION or others.
- The information contained herein is subject to change without notice.

**Electrical Characteristics (Ta = 25°C)**

Characteristic		Symbol	Test Circuit	Test Condition	Min	Typ.	Max	Unit
Collector cut-off current	RN1407~1409	$I_{CBO}$	—	$V_{CB} = 50V, I_E = 0$	—	—	100	nA
		$I_{CEO}$		$V_{CE} = 50V, I_B = 0$	—	—	500	
Emitter cut-off current	RN1407	$I_{EBO}$	—	$V_{EB} = 6V, I_C = 0$	0.081	—	0.15	mA
	RN1408			$V_{EB} = 7V, I_C = 0$	0.078	—	0.145	
	RN1409			$V_{EB} = 15V, I_C = 0$	0.167	—	0.311	
DC current gain	RN1407	$h_{FE}$	—	$V_{CE} = 5V, I_C = 10mA$	80	—	—	—
	RN1408				80	—	—	
	RN1409				70	—	—	
Collector-emitter saturation voltage	RN1407~1409	$V_{CE(sat)}$	—	$I_C = 5mA, I_B = 0.25mA$	—	0.1	0.3	V
Input voltage (ON)	RN1407	$V_{I(ON)}$	—	$V_{CE} = 0.2V, I_C = 5mA$	0.7	—	1.8	V
	RN1408				1.0	—	2.6	
	RN1409				2.2	—	5.8	
Input voltage (OFF)	RN1407	$V_{I(OFF)}$	—	$V_{CE} = 5V, I_C = 0.1mA$	0.5	—	1.0	V
	RN1408				0.6	—	1.16	
	RN1409				1.5	—	2.6	
Transition frequency	RN1407~1409	$f_T$	—	$V_{CE} = 10V, I_C = 5mA$	—	250	—	MHz
Collector Output capacitance	RN1407~1409	$C_{ob}$	—	$V_{CB} = 10V, I_E = 0, f = 1MHz$	—	3	6	pF
Input resistor	RN1407	R1	—	—	7	10	13	kΩ
	RN1408				15.4	22	28.6	
	RN1409				32.9	47	61.1	
Resistor ratio	RN1407	R1/R2	—	—	0.191	0.213	0.232	—
	RN1408				0.421	0.468	0.515	
	RN1409				1.92	2.14	2.35	

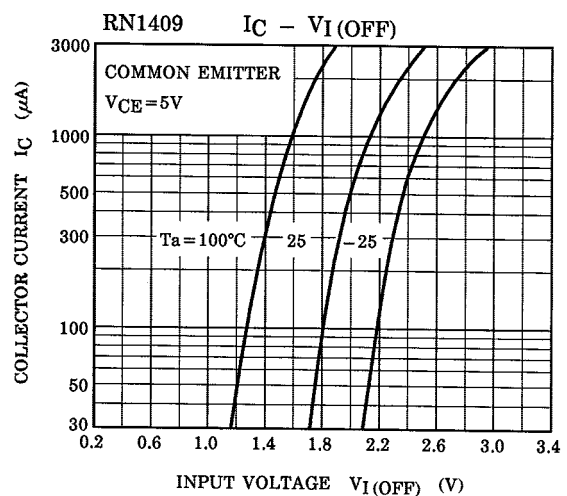
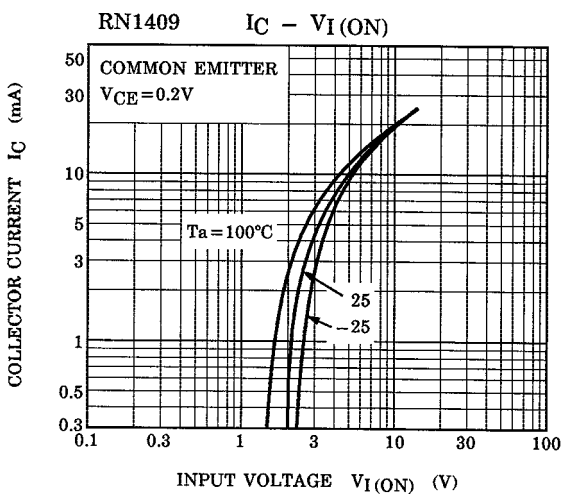
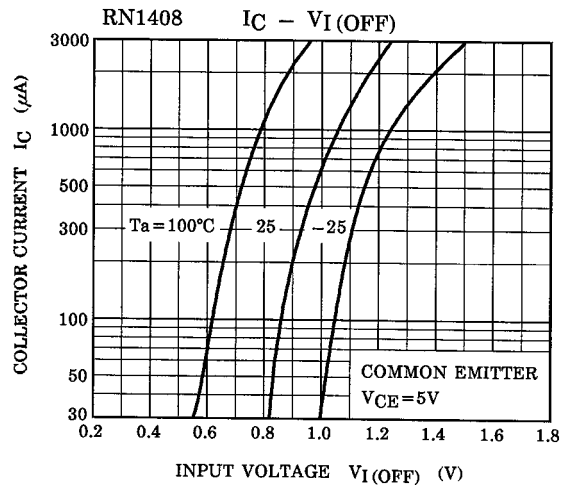
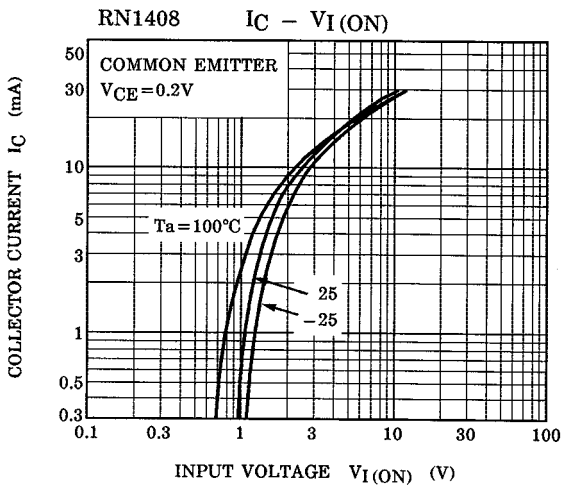
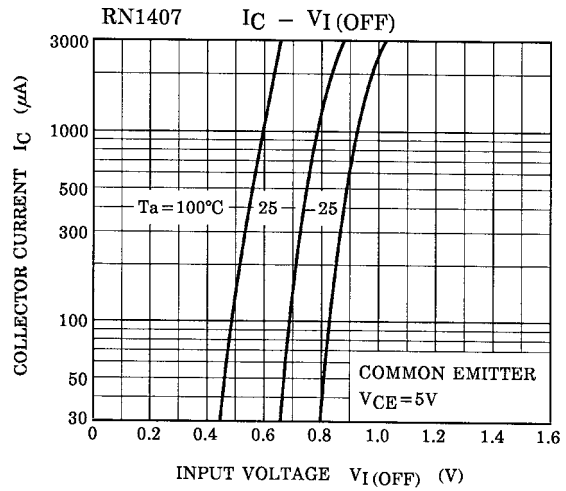
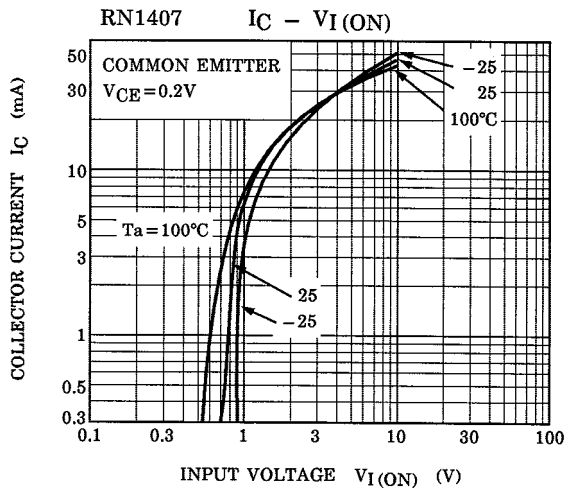

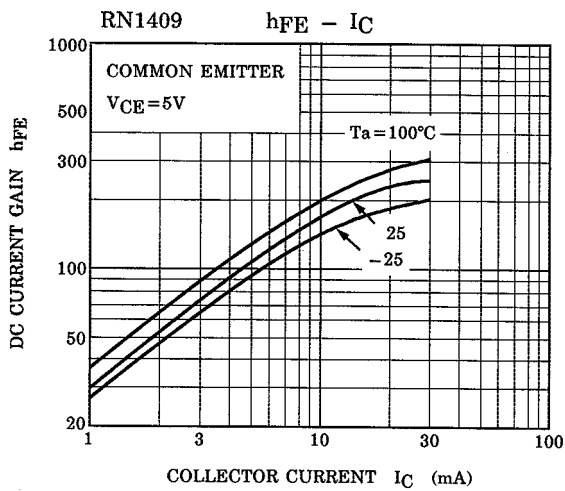
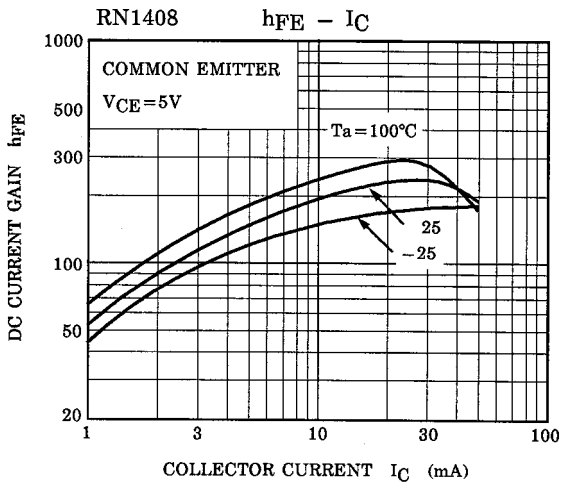
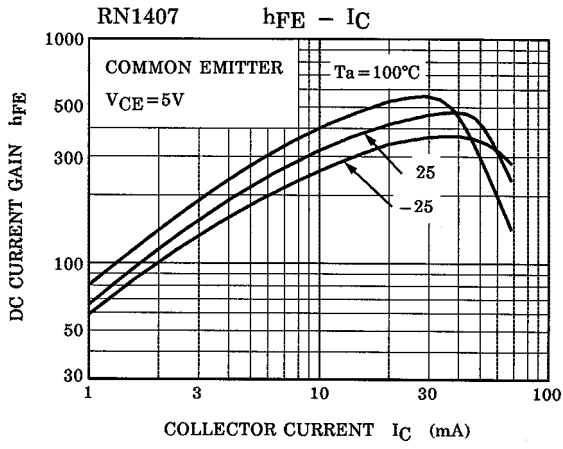

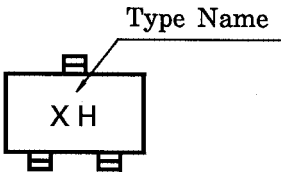
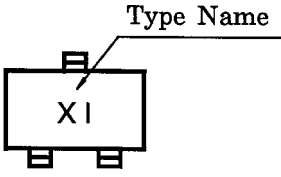
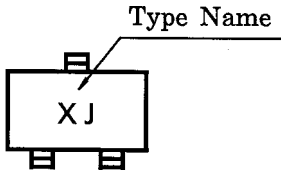
Type No.	Marking
RN1407	 <p>The diagram shows a rectangular component with a top terminal and two bottom terminals. The marking 'X H' is centered on the component. A line points from the text 'Type Name' to the 'X' in the marking.</p>
RN1408	 <p>The diagram shows a rectangular component with a top terminal and two bottom terminals. The marking 'X I' is centered on the component. A line points from the text 'Type Name' to the 'X' in the marking.</p>
RN1409	 <p>The diagram shows a rectangular component with a top terminal and two bottom terminals. The marking 'X J' is centered on the component. A line points from the text 'Type Name' to the 'X' in the marking.</p>