

TOSHIBA Transistor Silicon NPN Epitaxial Type (PCT Process)

RN1501,RN1502,RN1503 RN1504,RN1505,RN1506

Switching, Inverter Circuit, Interface Circuit
And Driver Circuit Applications

- Including two devices in SMV (super mini type with 5 leads)
- With built-in bias resistors
- Simplify circuit design
- Reduce a quantity of parts and manufacturing process
- Complementary to RN2501~RN2506

Equivalent Circuit and Bias Resistor Values

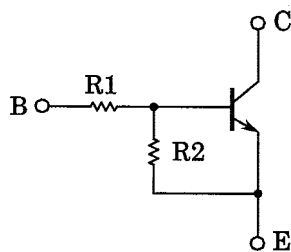

Type No.	R1 (kΩ)	R2 (kΩ)
RN1501	4.7	4.7
RN1502	10	10
RN1503	22	22
RN1504	47	47
RN1505	2.2	47
RN1506	4.7	47

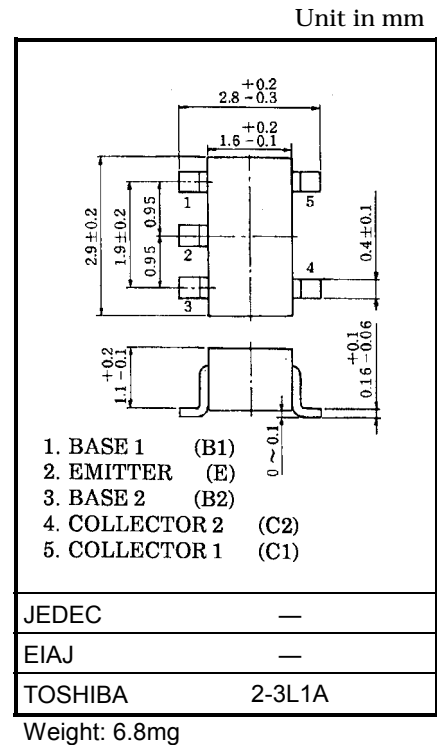

Equivalent Circuit (Top View)

Maximum Ratings (Ta = 25°C) (Q1, Q2 Common)

Characteristic	Symbol	Rating	Unit	
Collector-base voltage	RN1501~1506	V_{CBO}	50	V
Collector-emitter voltage		V_{CEO}	50	V
Emitter-base voltage	RN1501~1504	V_{EBO}	10	V
	RN1505, 1506		5	
Collector current	RN1501~1506	I_C	100	mA
Collector power dissipation		P_C *	300	mW
Junction temperature		T_j	150	°C
Storage temperature range		T_{stg}	-55~150	°C

* Total rating

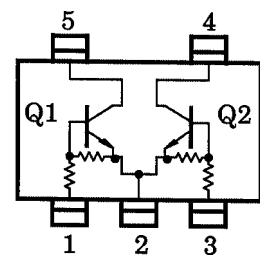

961001EAA2

- TOSHIBA is continually working to improve the quality and the reliability of its products. Nevertheless, semiconductor devices in general can malfunction or fail due to their inherent electrical sensitivity and vulnerability to physical stress. It is the responsibility of the buyer, when utilizing TOSHIBA products, to observe standards of safety, and to avoid situations in which a malfunction or failure of a TOSHIBA product could cause loss of human life, bodily injury or damage to property. In developing your designs, please ensure that TOSHIBA products are used within specified operating ranges as set forth in the most recent products specifications. Also, please keep in mind the precautions and conditions set forth in the TOSHIBA Semiconductor Reliability Handbook.
- The information contained herein is presented only as a guide for the applications of our products. No responsibility is assumed by TOSHIBA CORPORATION for any infringements of intellectual property or other rights of the third parties which may result from its use. No license is granted by implication or otherwise under any intellectual property or other rights of TOSHIBA CORPORATION or others.
- The information contained herein is subject to change without notice.

Electrical Characteristics (Ta = 25°C) (Q1, Q2 Common)

Characteristic		Symbol	Test Circuit	Test Condition	Min	Typ.	Max	Unit
Collector cut-off current	RN1501~1506	I_{CBO}	—	$V_{CB} = 50V, I_E = 0$	—	—	100	nA
		I_{CEO}		$V_{CE} = 50V, I_B = 0$	—	—	500	
Emitter cut-off current	RN1501	I_{EBO}	—	$V_{EB} = 10V, I_C = 0$	0.82	—	1.52	mA
	RN1502				0.38	—	0.71	
	RN1503				0.17	—	0.33	
	RN1504			0.082	—	0.15		
	RN1505			$V_{EB} = 5V, I_C = 0$	0.078	—	0.145	
	RN1506				0.074	—	0.138	
DC current gain	RN1501	h_{FE}	—	$V_{CE} = 5V, I_C = 10mA$	30	—	—	
	RN1502				50	—	—	
	RN1503				70	—	—	
	RN1504				80	—	—	
	RN1505				80	—	—	
	RN1506				80	—	—	
Collector-emitter saturation voltage	RN1501~1506	$V_{CE(sat)}$	—	$I_C = 5mA, I_B = 0.25mA$	—	0.1	0.3	V
Input voltage (ON)	RN1501	$V_{I(ON)}$	—	$V_{CE} = 0.2V, I_C = 5mA$	1.1	—	2.0	V
	RN1502				1.2	—	2.4	
	RN1503				1.3	—	3.0	
	RN1504				1.5	—	5.0	
	RN1505				0.6	—	1.1	
	RN1506				0.7	—	1.3	
Input voltage (OFF)	RN1501~1504	$V_{I(OFF)}$	—	$V_{CE} = 5V, I_C = 0.1mA$	1.0	—	1.5	V
	RN1505, 1506				0.5	—	0.8	
Transition frequency	RN1501~1506	f_T	—	$V_{CE} = 10V, I_C = 5mA$	—	250	—	MHz
Collector Output capacitance	RN1501~1506	C_{ob}	—	$V_{CB} = 10V, I_E = 0, f = 1MHz$	—	3	6	pF
Input resistor	RN1501	R1	—		3.29	4.7	6.11	kΩ
	RN1502				7	10	13	
	RN1503				15.4	22	28.6	
	RN1504				32.9	47	61.1	
	RN1505				1.54	2.2	2.86	
	RN1506				3.29	4.7	6.11	
Resistor ratio	RN1501~1504	R1/R2	—		0.9	1.0	1.1	
	RN1505				0.0421	0.0468	0.0515	
	RN1506				0.09	0.1	0.11	

(Q1, Q2 COMMON)

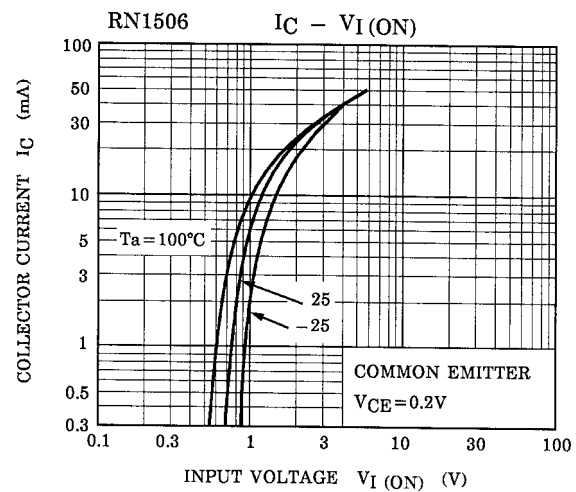
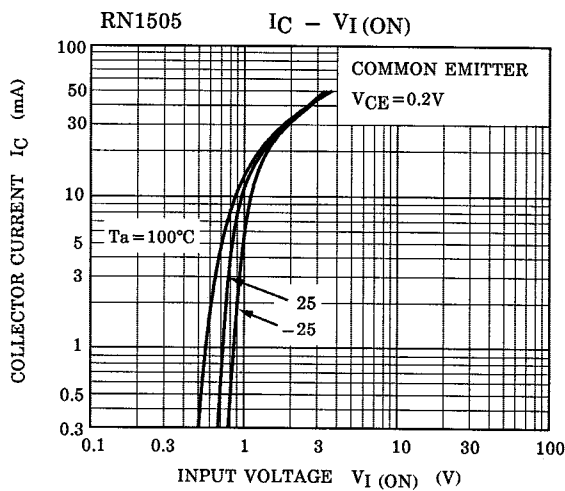
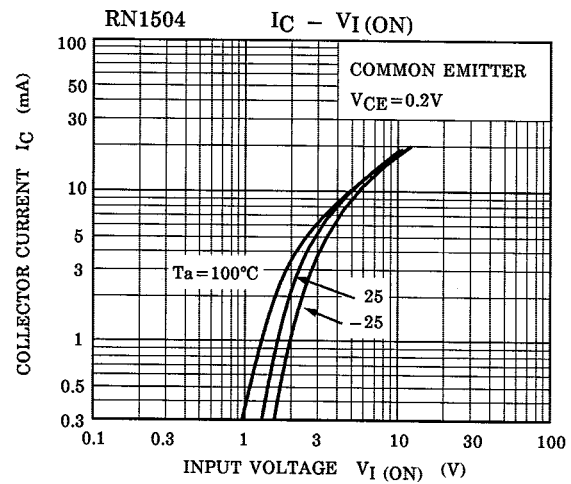
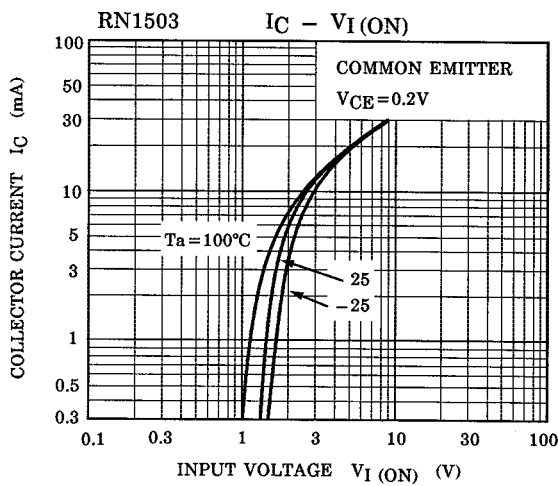
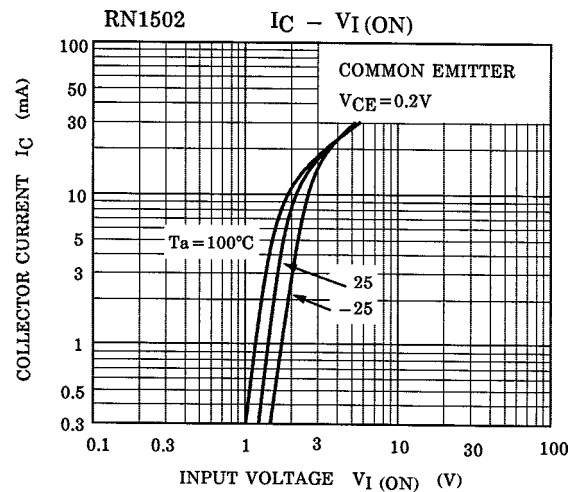
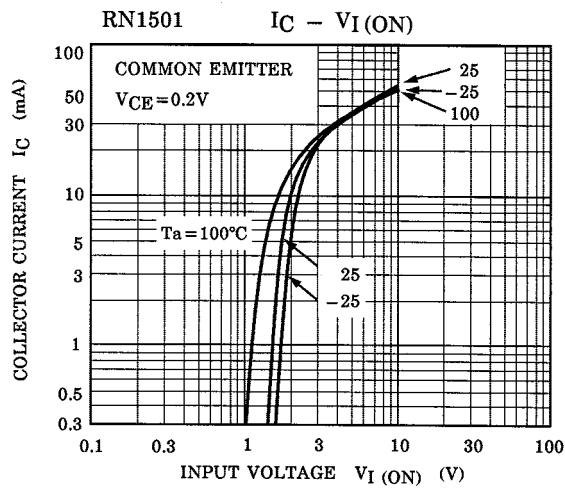

(Q1, Q2 COMMON)

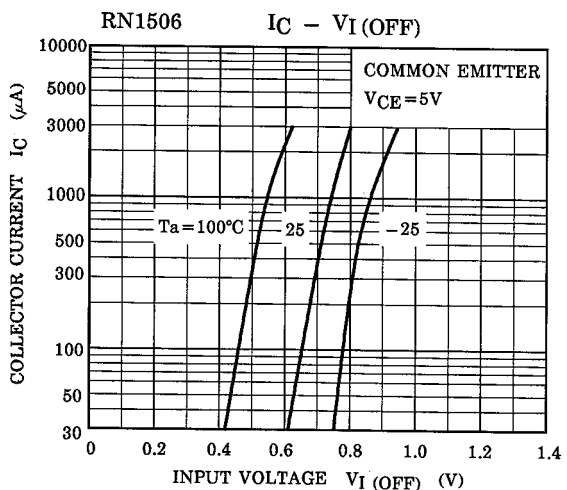
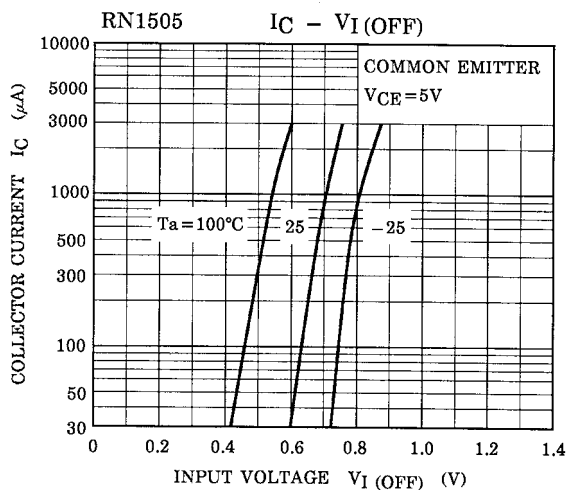
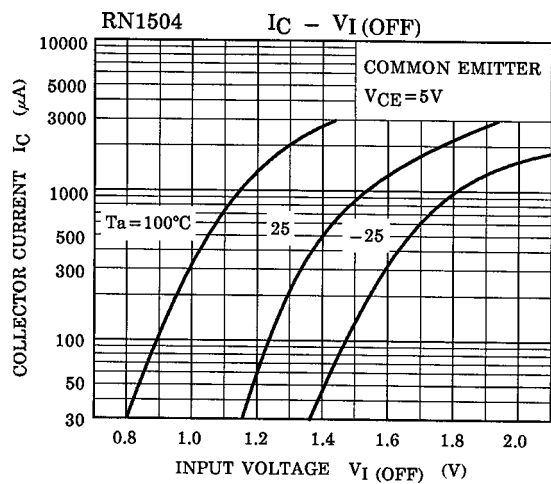
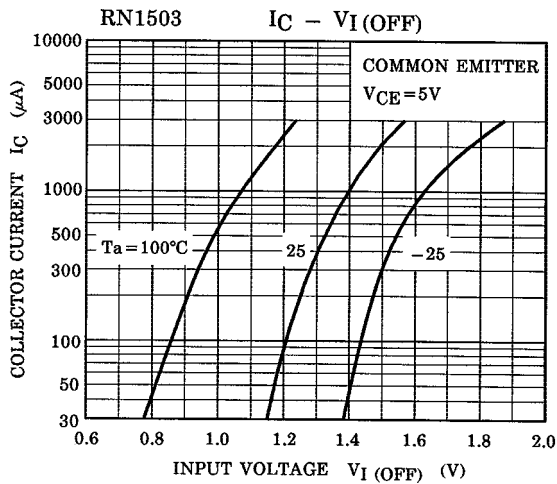
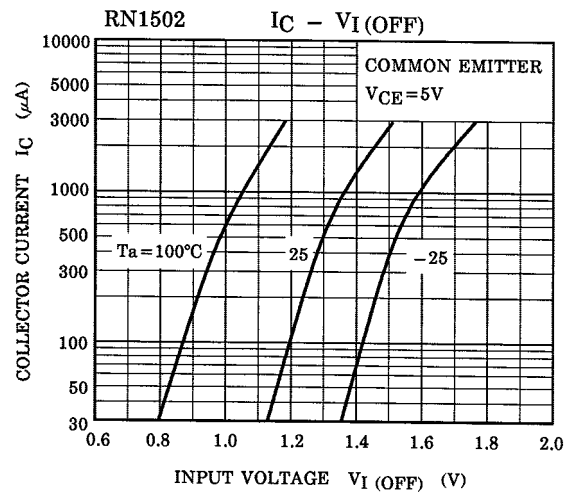
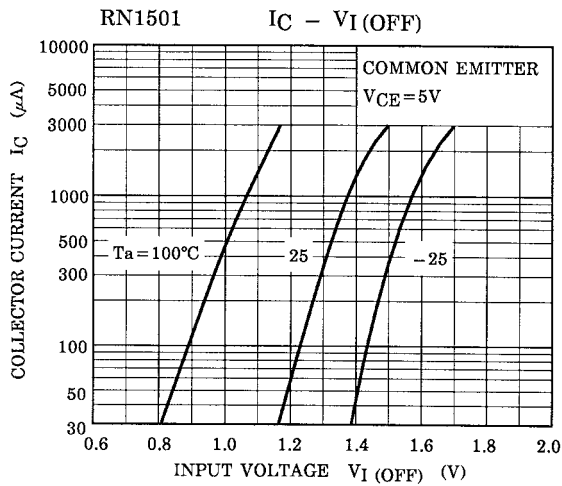

(Q1, Q2 COMMON)

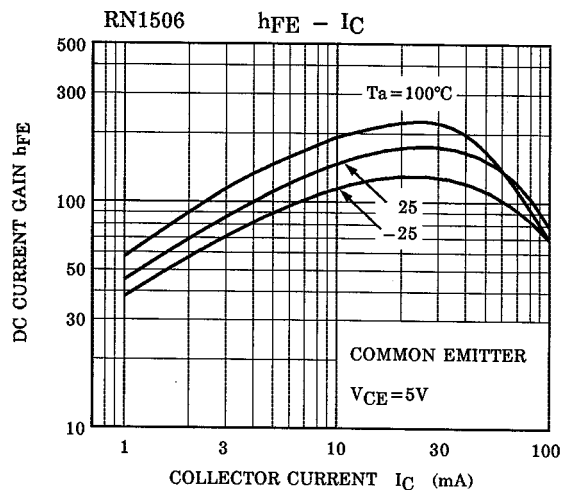
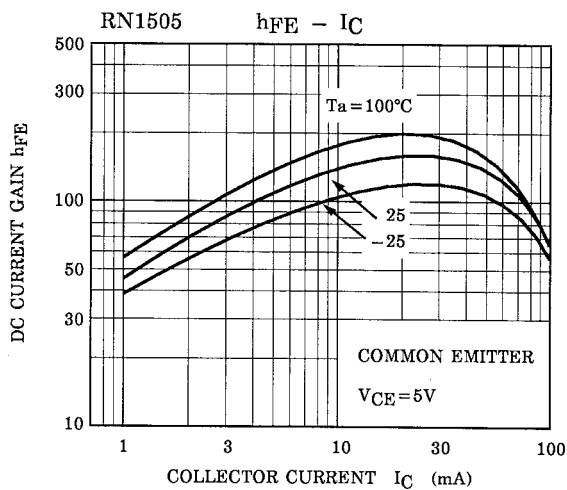
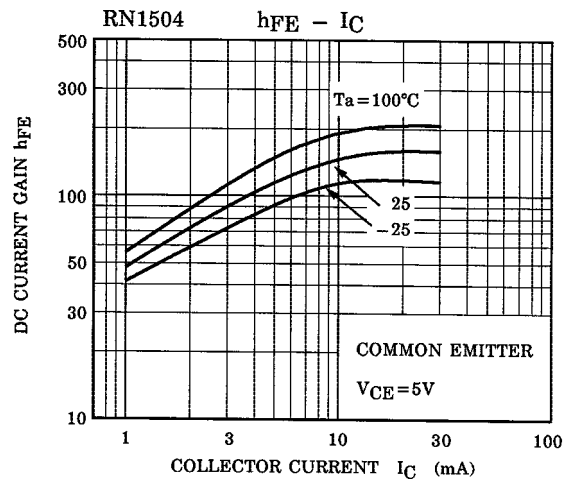
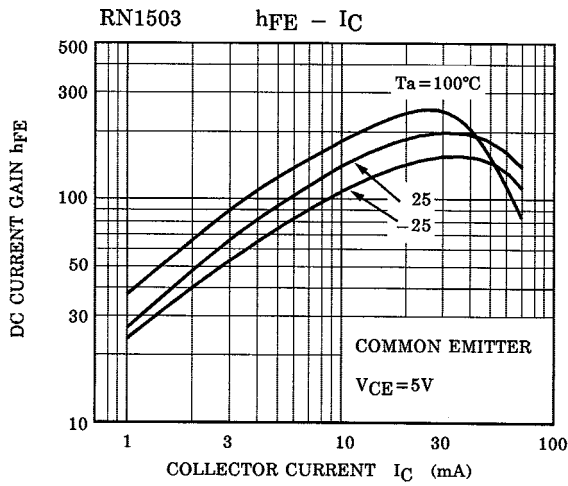
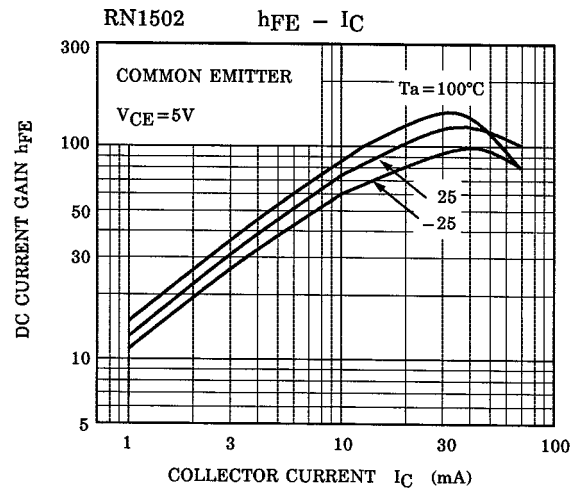
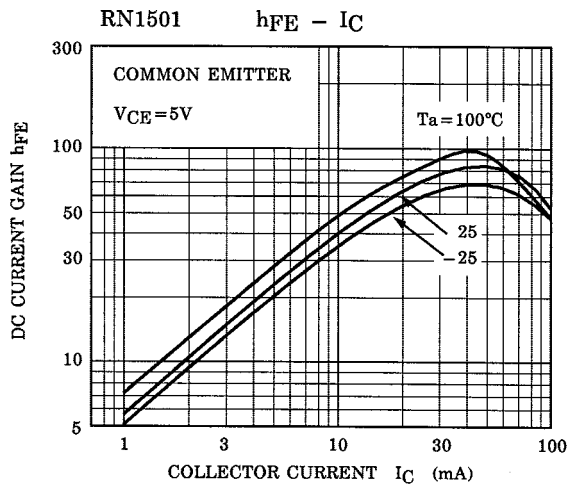

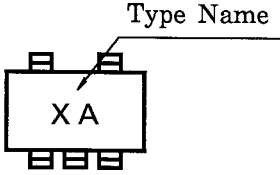
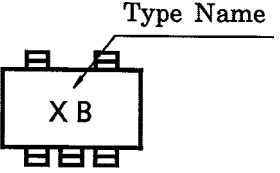
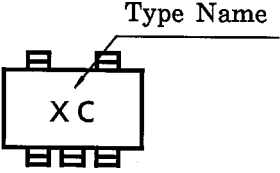
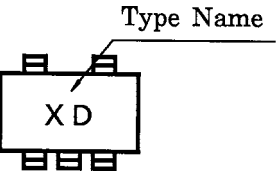
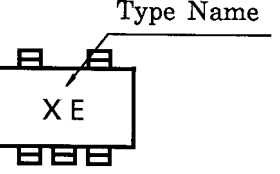
Type Name	Marking
RN1501	
RN1502	
RN1503	
RN1504	
RN1505	
RN1506	