

TOSHIBA Transistor Silicon NPN Epitaxial Type (PCT Process)

# RN1507, RN1508, RN1509

Switching, Inverter Circuit, Interface Circuit  
And Driver Circuit Applications

Unit in mm

- Including two devices in SMV (super mini type with 5 leads) With built-in bias resistors
- Simplify circuit design
- Reduce a quantity of parts and manufacturing process
- Complementary to RN2507~RN2509

## Equivalent Circuit and Bias Resistor Values

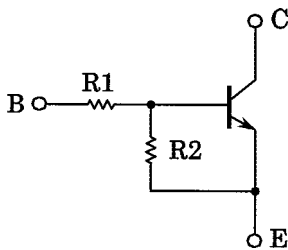

Type No.	R1 (kΩ)	R2 (kΩ)
RN1907	10	47
RN1908	22	47
RN1909	47	22

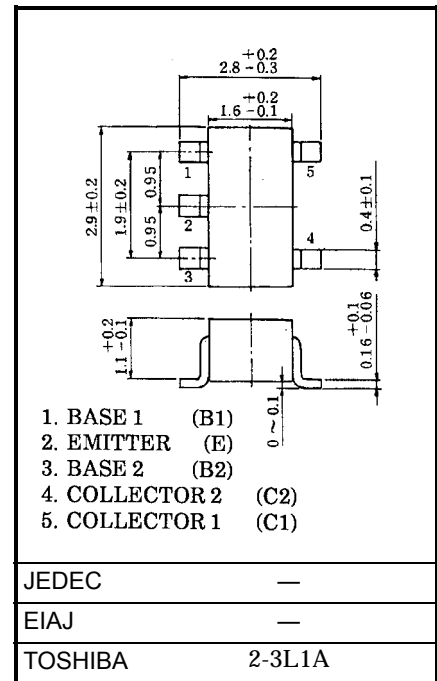

Weight: 0.014g

## Equivalent Circuit (Top View)

## Maximum Ratings (Ta = 25°C) (Q1, Q2 Common)

Characteristic	Symbol	Rating	Unit	
Collector-base voltage	RN1507~1509	$V_{CBO}$	50	V
Collector-emitter voltage		$V_{CEO}$	50	V
Emitter-base voltage	$V_{EBO}$	RN1507	6	V
		RN1508	7	
		RN1509	15	
Collector current	RN1507~1509	$I_C$	100	mA
Collector power dissipation		$P_C^*$	300	mW
Junction temperature		$T_j$	150	°C
Storage temperature range		$T_{stg}$	-55~150	°C

\* : Total rating

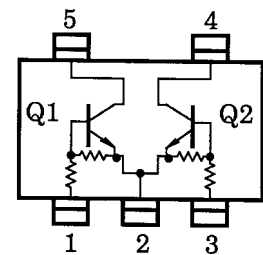

961001EAA2

- TOSHIBA is continually working to improve the quality and the reliability of its products. Nevertheless, semiconductor devices in general can malfunction or fail due to their inherent electrical sensitivity and vulnerability to physical stress. It is the responsibility of the buyer, when utilizing TOSHIBA products, to observe standards of safety, and to avoid situations in which a malfunction or failure of a TOSHIBA product could cause loss of human life, bodily injury or damage to property. In developing your designs, please ensure that TOSHIBA products are used within specified operating ranges as set forth in the most recent products specifications. Also, please keep in mind the precautions and conditions set forth in the TOSHIBA Semiconductor Reliability Handbook.
- The information contained herein is presented only as a guide for the applications of our products. No responsibility is assumed by TOSHIBA CORPORATION for any infringements of intellectual property or other rights of the third parties which may result from its use. No license is granted by implication or otherwise under any intellectual property or other rights of TOSHIBA CORPORATION or others.
- The information contained herein is subject to change without notice.

**Electrical Characteristics (Ta = 25°C) (Q1, Q2 Common)**

Characteristic		Symbol	Test Circuit	Test Condition	Min	Typ.	Max	Unit
Collector cut-off current	RN1507~1509	$I_{CBO}$	—	$V_{CB} = 50V, I_E = 0$	—	—	100	nA
		$I_{CEO}$		$V_{CE} = 50V, I_B = 0$	—	—	500	nA
Emitter cut-off current	RN1507	$I_{EBO}$	—	$V_{EB} = 6V, I_C = 0$	0.081	—	0.15	mA
	RN1508			$V_{EB} = 7V, I_C = 0$	0.078	—	0.145	
	RN1509			$V_{EB} = 15V, I_C = 0$	0.167	—	0.311	
DC current gain	RN1507	$h_{FE}$	—	$V_{CE} = 5V, I_C = 10mA$	80	—	—	
	RN1508				80	—	—	
	RN1509				70	—	—	
Collector-emitter saturation voltage	RN1507~1509	$V_{CE(sat)}$	—	$I_C = 5mA, I_B = 0.25mA$	—	0.1	0.3	V
Input voltage (ON)	RN1507	$V_{I(ON)}$	—	$V_{CE} = 0.2V, I_C = 5mA$	0.7	—	1.8	V
	RN1508				1.0	—	2.6	
	RN1509				2.2	—	5.8	
Input voltage (OFF)	RN1507	$V_{I(OFF)}$	—	$V_{CE} = 5V, I_C = 0.1mA$	0.5	—	1.0	V
	RN1508				0.6	—	1.16	
	RN1509				1.5	—	2.6	
Transition frequency	RN1507~1509	$f_T$	—	$V_{CE} = 10V, I_C = 5mA$	—	250	—	MHz
Collector Output capacitance	RN1507~1509	$C_{ob}$	—	$V_{CB} = 10V, I_E = 0, f = 1MHz$	—	3	6	pF
Input resistor	RN1507	R1	—		7	10	13	kΩ
	RN1508				15.4	22	28.6	
	RN1509				32.9	47	61.1	
Resistor ratio	RN1507	R1/R2	—		0.191	0.213	0.232	
	RN1508				0.421	0.468	0.515	
	RN1509				1.92	2.14	2.35	

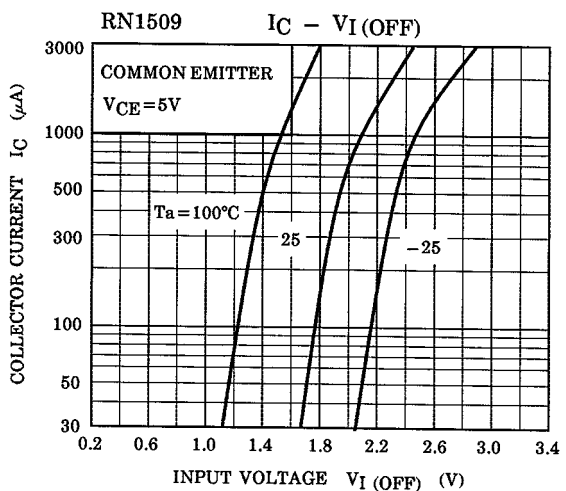
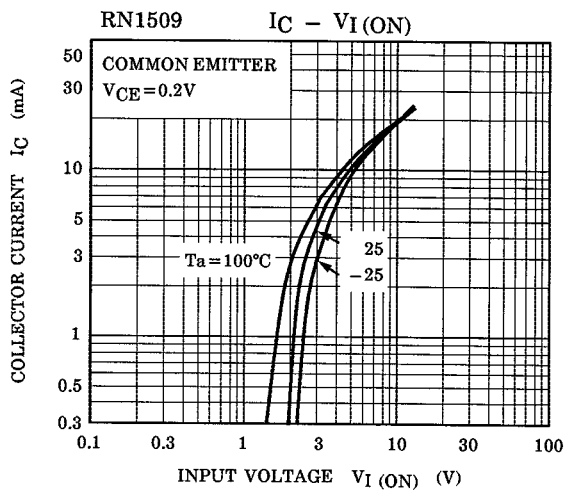
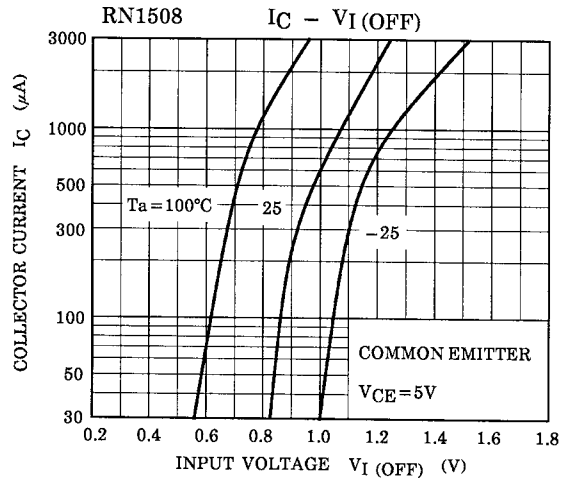
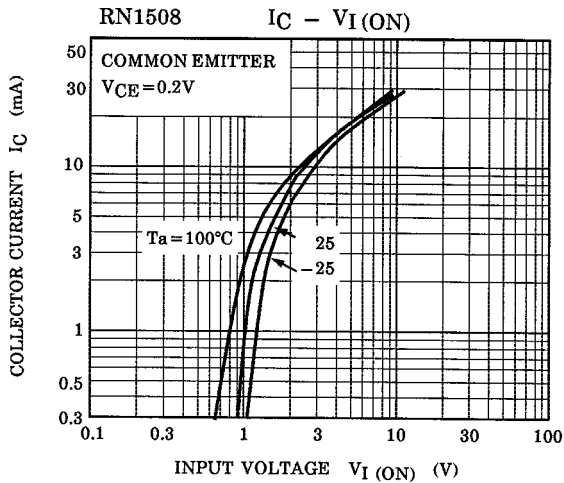
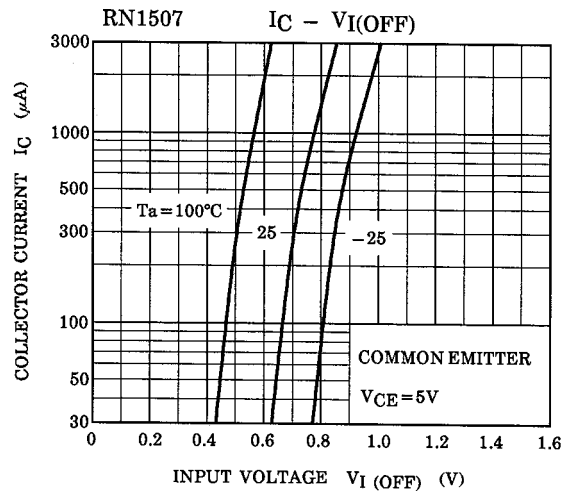
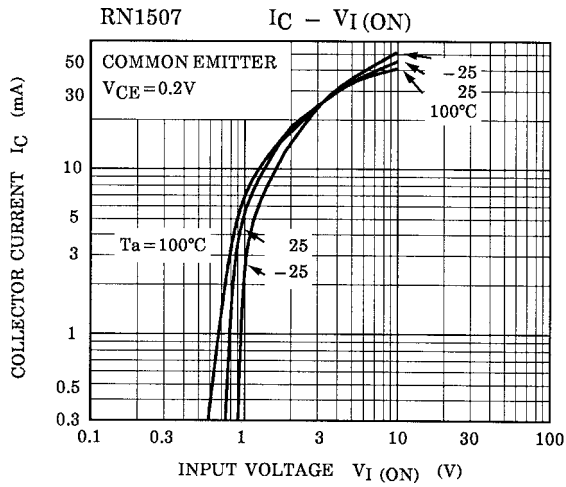

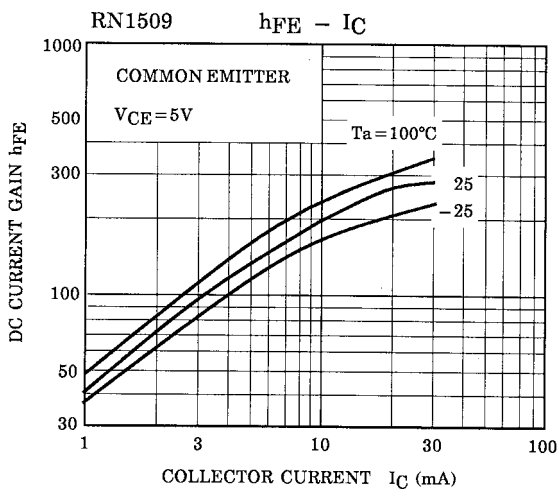
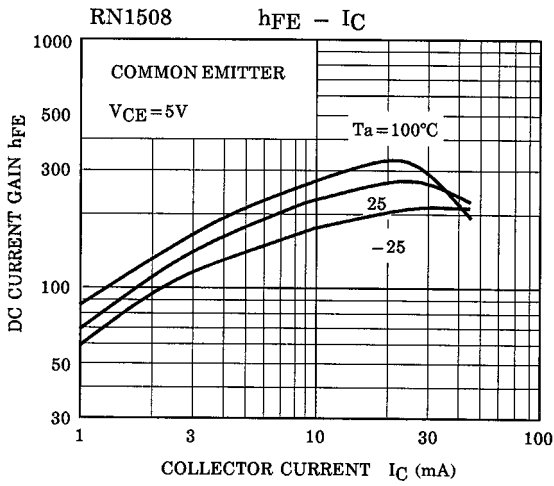
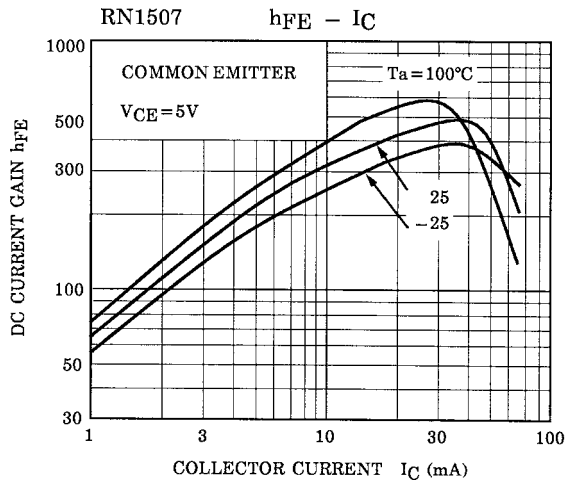

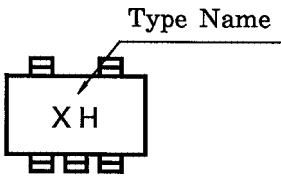
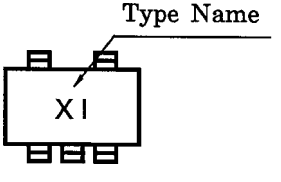
Type Name	Marking
RN1507	
RN1508	
RN1509	