

TOSHIBA Transistor Silicon NPN Epitaxial Type (PCT Process)

## RN1701,RN1702,RN1703 RN1704,RN1705,RN1706

Switching, Inverter Circuit, Interface Circuit  
And Driver Circuit Applications

- Including two devices in USV (ultra super mini type with 5 leads)
- With built-in bias resistors
- Simplify circuit design
- Reduce a quantity of parts and manufacturing process
- Complementary to RN2701~RN2706

### Equivalent Circuit and Bias Resistor Values

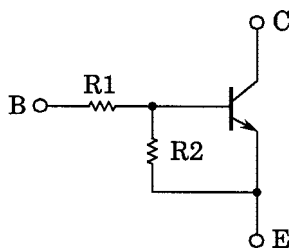

Type No.	R1 (kΩ)	R2 (kΩ)
RN1701	4.7	4.7
RN1702	10	10
RN1703	22	22
RN1704	47	47
RN1705	2.2	47
RN1706	4.7	47

Unit in mm

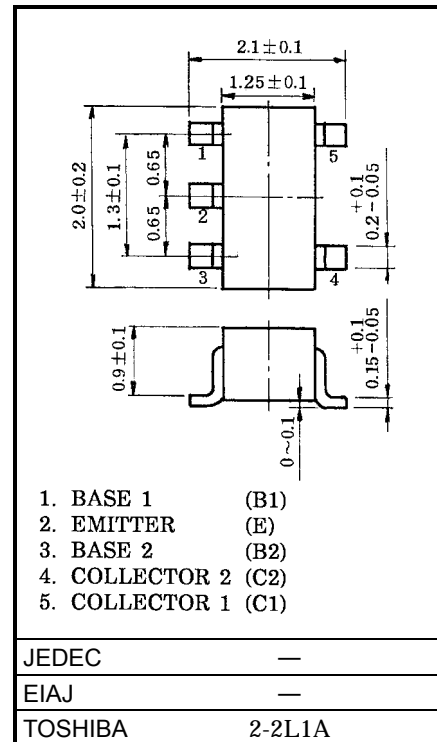

Weight: 6.2mg

### Equivalent Circuit (Top View)

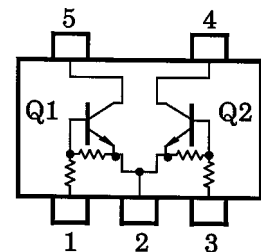

### Maximum Ratings (Ta = 25°C) (Q1, Q2 Common)

Characteristic		Symbol	Rating	Unit
Collector-base voltage	RN1701~1706	$V_{CBO}$	50	V
Collector-emitter voltage		$V_{CEO}$	50	V
Emitter-base voltage	RN1701~1704	$V_{EBO}$	10	V
	RN1705, 1706		5	
Collector current	RN1701~1706	$I_c$	100	mA
Collector power dissipation		$P_c^*$	200	mW
Junction temperature		$T_j$	150	°C
Storage temperature range		$T_{stg}$	-55~150	°C

\*: Total rating

961001EAA2

● TOSHIBA is continually working to improve the quality and the reliability of its products. Nevertheless, semiconductor devices in general can malfunction or fail due to their inherent electrical sensitivity and vulnerability to physical stress. It is the responsibility of the buyer, when utilizing TOSHIBA products, to observe standards of safety, and to avoid situations in which a malfunction or failure of a TOSHIBA product could cause loss of human life, bodily injury or damage to property. In developing your designs, please ensure that TOSHIBA products are used within specified operating ranges as set forth in the most recent products specifications. Also, please keep in mind the precautions and conditions set forth in the TOSHIBA Semiconductor Reliability Handbook.

## Electrical Characteristics (Ta = 25°C) (Q1, Q2 Common)

Characteristic		Symbol	Test Circuit	Test Condition	Min	Typ.	Max	Unit
Collector cut-off current	RN1701~1706	$I_{CBO}$	—	$V_{CB} = 50V, I_E = 0$	—	—	100	nA
		$I_{CEO}$	—	$V_{CE} = 50V, I_B = 0$	—	—	500	
Emitter cut-off current	RN1701	$I_{EBO}$	—	$V_{EB} = 10V, I_C = 0$	0.82	—	1.52	mA
	RN1702		—		0.38	—	0.71	
	RN1703		—		0.17	—	0.33	
	RN1704		—	0.082	—	0.15		
	RN1705		$V_{EB} = 5V, I_C = 0$	—	0.078	—	0.145	
	RN1706			—	0.074	—	0.138	
DC current gain	RN1701	$h_{FE}$	—	$V_{CE} = 5V, I_C = 10mA$	30	—	—	—
	RN1702		—		50	—	—	
	RN1703		—		70	—	—	
	RN1704		—		80	—	—	
	RN1705		—		80	—	—	
	RN1706		—		80	—	—	
Collector-emitter saturation voltage	RN1701~1706	$V_{CE(sat)}$	—	$I_C = 5mA, I_B = 0.25mA$	—	0.1	0.3	V
Input voltage (ON)	RN1701	$V_{I(ON)}$	—	$V_{CE} = 0.2V, I_C = 5mA$	1.1	—	2.0	V
	RN1702		—		1.2	—	2.4	
	RN1703		—		1.3	—	3.0	
	RN1704		—		1.5	—	5.0	
	RN1705		—		0.6	—	1.1	
	RN1706		—		0.7	—	1.3	
Input voltage (OFF)	RN1701~1704	$V_{I(OFF)}$	—	$V_{CE} = 5V, I_C = 0.1mA$	1.0	—	1.5	V
	RN1705, 1706		—		0.5	—	0.8	
Transition frequency	RN1701~1706	$f_T$	—	$V_{CE} = 10V, I_C = 5mA$	—	250	—	MHz
Collector output capacitance	RN1701~1706	$C_{ob}$	—	$V_{CB} = 10V, I_E = 0, f = 1MHz$	—	3	6	pF
Input resistor	RN1701	R1	—	—	3.29	4.7	6.11	kΩ
	RN1702		—		7	10	13	
	RN1703		—		15.4	22	28.6	
	RN1704		—		32.9	47	61.1	
	RN1705		—		1.54	2.2	2.86	
	RN1706		—		3.29	4.7	6.11	
Resistor ratio	RN1701~1705	R1/R2	—	—	0.9	1.0	1.1	—
	RN1705		—		0.0421	0.0468	0.0515	
	RN1706		—		0.09	0.1	0.11	

961001EAA2

- The information contained herein is presented only as a guide for the applications of our products. No responsibility is assumed by TOSHIBA CORPORATION for any infringements of intellectual property or other rights of the third parties which may result from its use. No license is granted by implication or otherwise under any intellectual property or other rights of TOSHIBA CORPORATION or others.
- The information contained herein is subject to change without notice.

(Q1, Q2 Common)

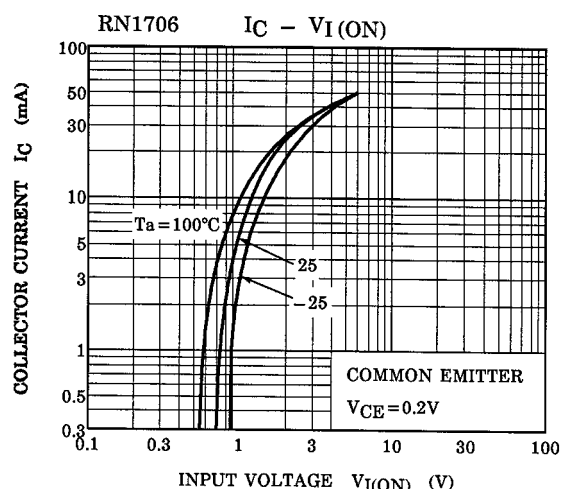
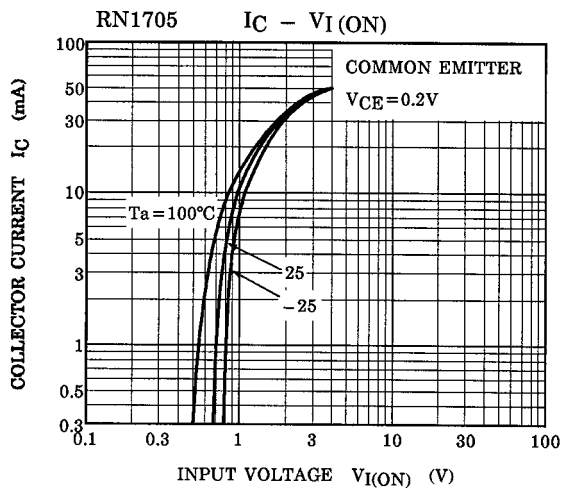
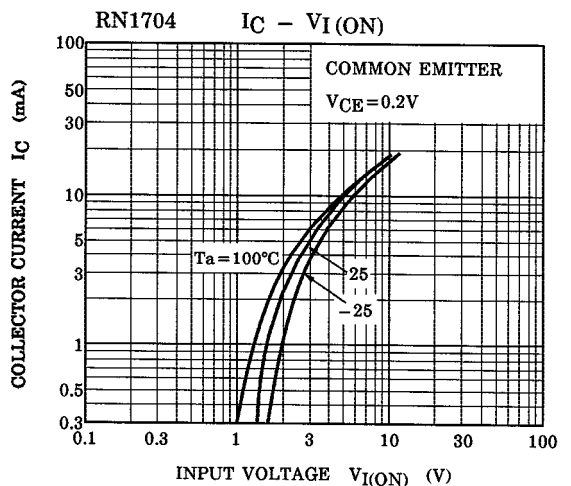
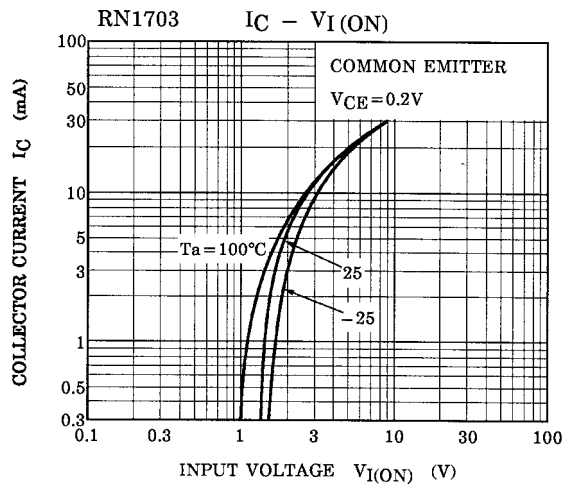
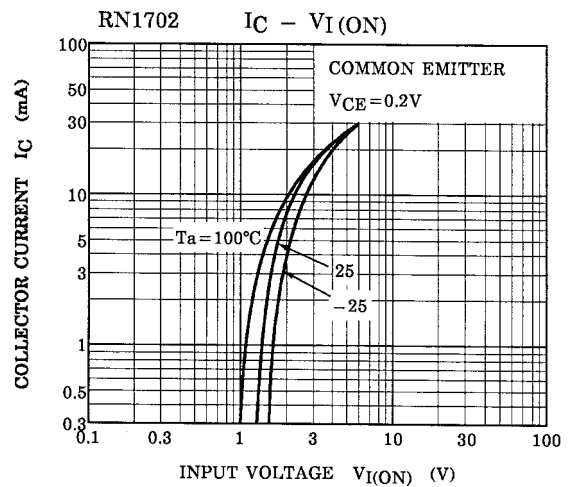
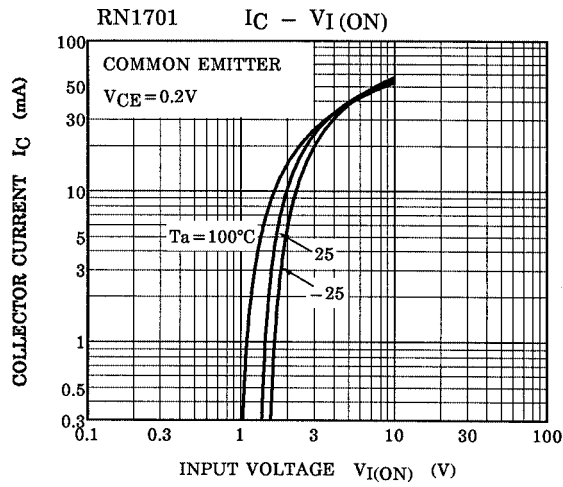

(Q1, Q2 Common)

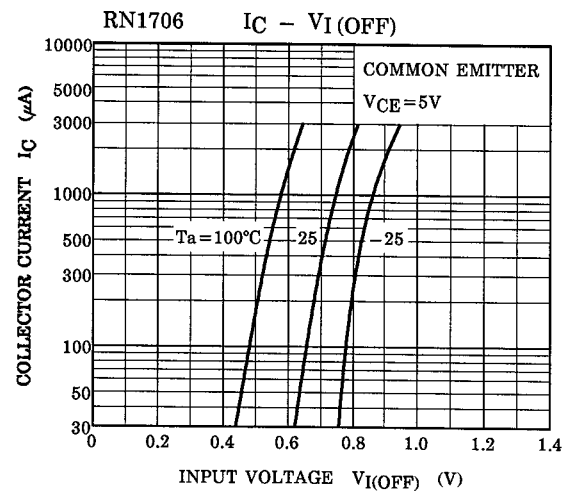
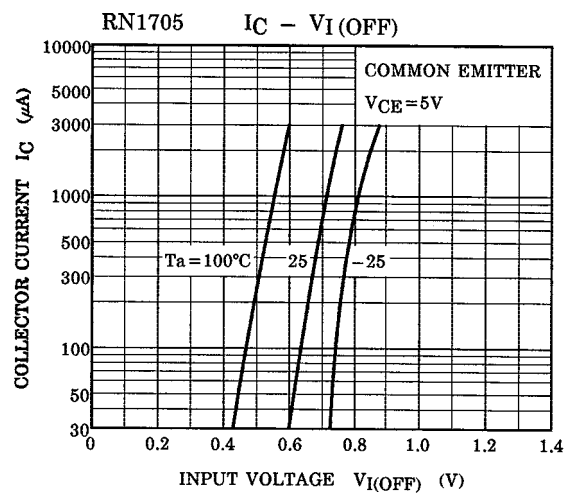
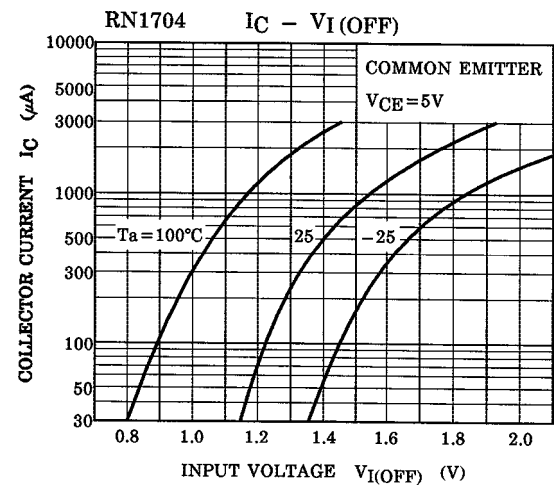
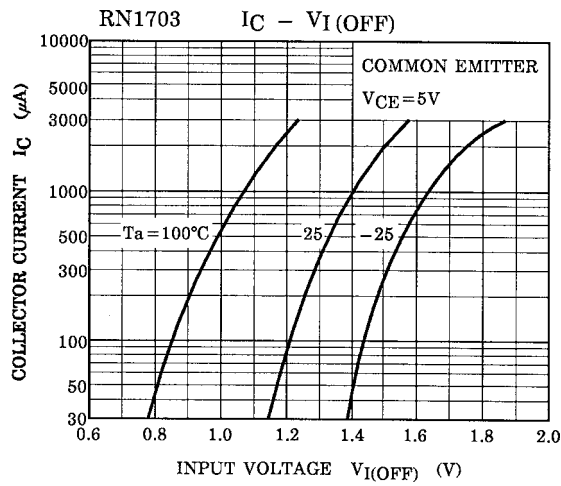
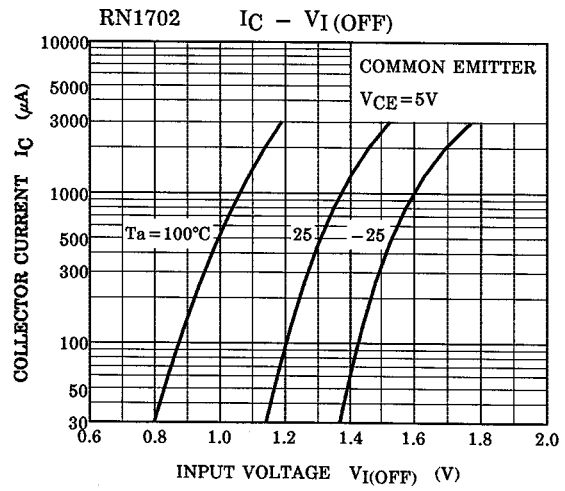
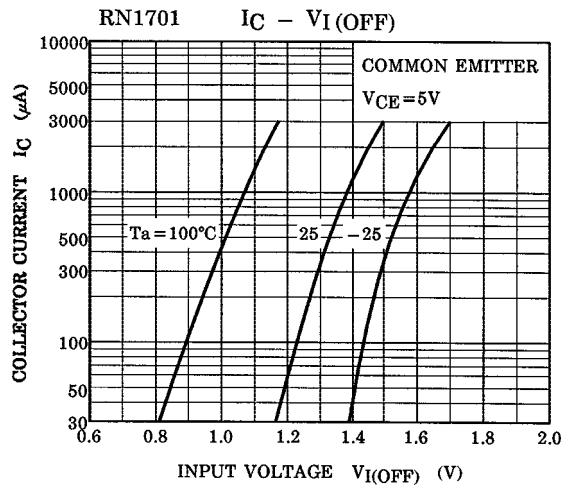

(Q1, Q2 Common)

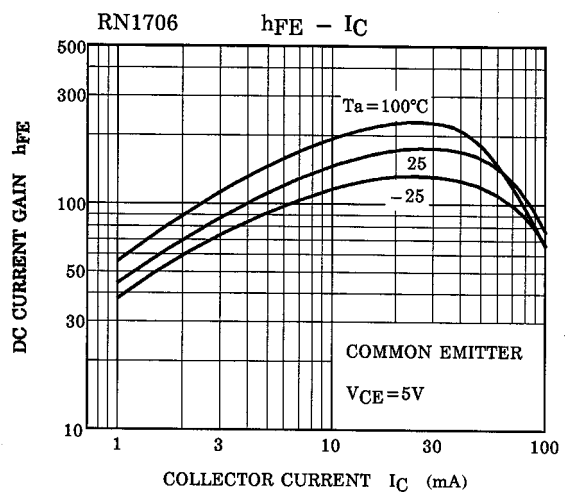
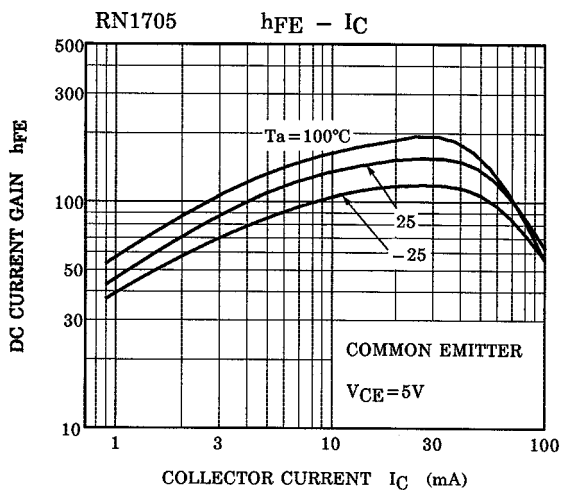
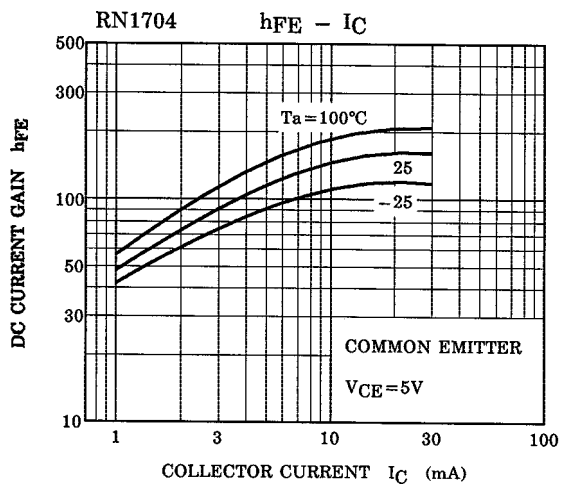
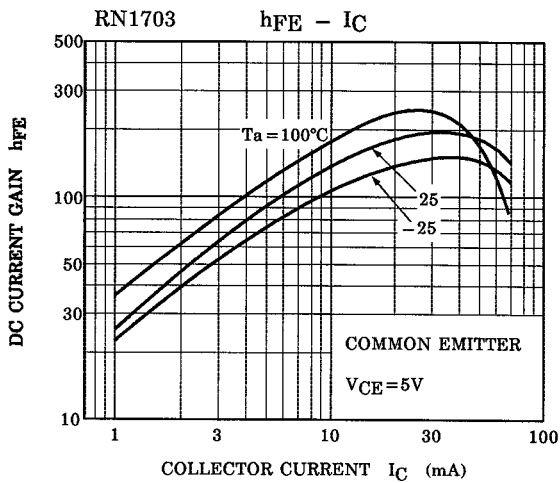
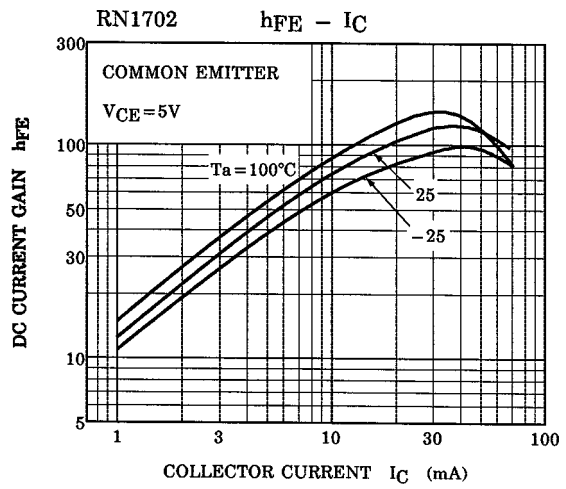
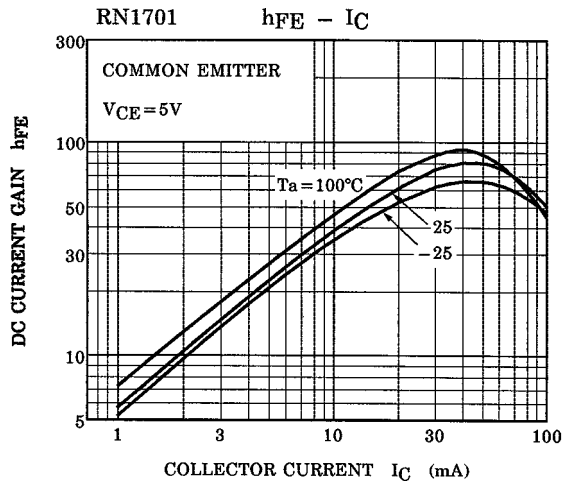

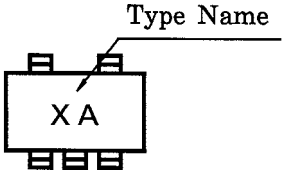
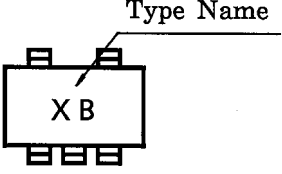
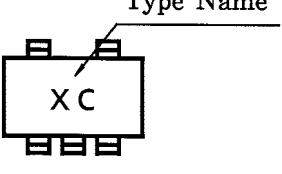
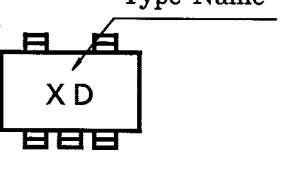
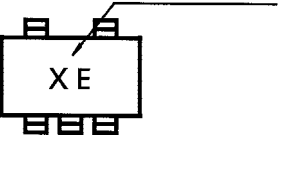
Type Name	Marking
RN1701	
RN1702	
RN1703	
RN1704	
RN1705	
RN1706	