

TOSHIBA Transistor Silicon NPN Epitaxial Type (PCT Process)

RN1961,RN1962,RN1963 RN1964,RN1965,RN1966

Switching, Inverter Circuit, Interface Circuit
And Driver Circuit Applications

- Including two devices in US6 (ultra super mini type 6 leads)
- With built-in bias resistors
- Simplify circuit design
- Reduce a quantity of parts and manufacturing process
 - Complementary to RN2961~RN2966

Equivalent Circuit and Bias Resistor Values

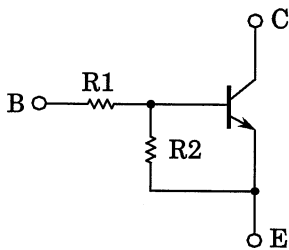

Type No.	R1 (kΩ)	R2 (kΩ)
RN1961	4.7	4.7
RN1962	10	10
RN1963	22	22
RN1964	47	47
RN1965	2.2	47
RN1966	4.7	47

Unit in mm

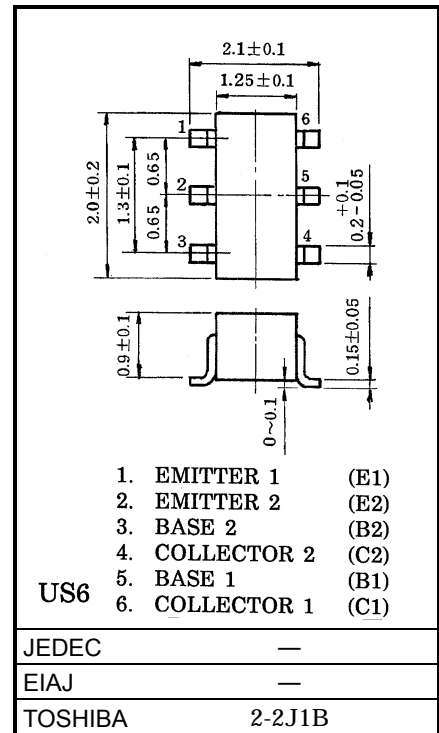

Equivalent Circuit (Top View)

Maximum Ratings (Ta = 25°C) (Q1, Q2 Common)

Characteristic		Symbol	Rating	Unit
Collector-base voltage	RN1961~1966	V_{CBO}	50	V
Collector-emitter voltage		V_{CEO}	50	V
Emitter-base voltage	RN1961~1964	V_{EBO}	10	V
	RN1965, 1966		5	
Collector current	RN1961~1966	I_C	100	mA
Collector power dissipation		P_C^*	200	mW
Junction temperature		T_j	150	°C
Storage temperature range		T_{stg}	-55~150	°C

*: Total rating

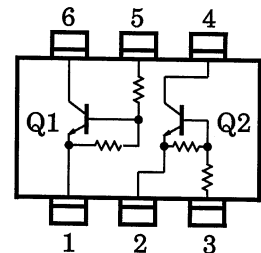

961001EAA2

● TOSHIBA is continually working to improve the quality and the reliability of its products. Nevertheless, semiconductor devices in general can malfunction or fail due to their inherent electrical sensitivity and vulnerability to physical stress. It is the responsibility of the buyer, when utilizing TOSHIBA products, to observe standards of safety, and to avoid situations in which a malfunction or failure of a TOSHIBA product could cause loss of human life, bodily injury or damage to property. In developing your designs, please ensure that TOSHIBA products are used within specified operating ranges as set forth in the most recent products specifications. Also, please keep in mind the precautions and conditions set forth in the TOSHIBA Semiconductor Reliability Handbook.

Electrical Characteristics (Ta = 25°C) (Q1, Q2 Common)

Characteristic		Symbol	Test Circuit	Test Condition	Min	Typ.	Max	Unit
Collector cut-off current	RN1961~1966	I_{CBO}	—	$V_{CB} = 50V, I_E = 0$	—	—	100	nA
		I_{CEO}	—	$V_{CE} = 50V, I_B = 0$	—	—	500	
Emitter cut-off current	RN1961	I_{EBO}	—	$V_{EB} = 10V, I_C = 0$	0.82	—	1.52	mA
	RN1962		—		0.38	—	0.71	
	RN1963		—		0.17	—	0.33	
	RN1964		—	0.082	—	0.15		
	RN1965		$V_{EB} = 5V, I_C = 0$	—	0.078	—	0.145	
	RN1966			—	0.074	—	0.138	
DC current gain	RN1961	h_{FE}	—	$V_{CE} = 5V, I_C = 10mA$	30	—	—	—
	RN1962		—		50	—	—	
	RN1963		—		70	—	—	
	RN1964		—		80	—	—	
	RN1965		—		80	—	—	
	RN1966		—		80	—	—	
Collector-emitter saturation voltage	RN1961~1966	$V_{CE(sat)}$	—	$I_C = 5mA, I_B = 0.25mA$	—	0.1	0.3	V
Input voltage (ON)	RN1961	$V_{I(ON)}$	—	$V_{CE} = 0.2V, I_C = 5mA$	1.1	—	2.0	V
	RN1962		—		1.2	—	2.4	
	RN1963		—		1.3	—	3.0	
	RN1964		—		1.5	—	5.0	
	RN1965		—		0.6	—	1.1	
	RN1966		—		0.7	—	1.3	
Input voltage (OFF)	RN1961~1964	$V_{I(OFF)}$	—	$V_{CE} = 5V, I_C = 0.1mA$	1.0	—	1.5	V
	RN1965, 1966		—		0.5	—	0.8	
Translation frequency	RN1961~1966	f_T	—	$V_{CE} = 10V, I_C = 5mA$	—	250	—	MHz
Collector output capacitance	RN1961~1966	C_{ob}	—	$V_{CB} = 10V, I_E = 0, f = 1MHz$	—	3	6	pF
Input resistor	RN1961	R1	—	—	3.29	4.7	6.11	kΩ
	RN1962		—		7	10	13	
	RN1963		—		15.4	22	28.6	
	RN1964		—		32.9	47	61.1	
	RN1965		—		1.54	2.2	2.86	
	RN1966		—		3.29	4.7	6.11	
Resistor ratio	RN1961~1965	R1/R2	—	—	0.9	1.0	1.1	—
	RN1965		—		0.0421	0.0468	0.0515	
	RN1966		—		0.09	0.1	0.11	

961001EAA2

- The information contained herein is presented only as a guide for the applications of our products. No responsibility is assumed by TOSHIBA CORPORATION for any infringements of intellectual property or other rights of the third parties which may result from its use. No license is granted by implication or otherwise under any intellectual property or other rights of TOSHIBA CORPORATION or others.
- The information contained herein is subject to change without notice.

(Q1, Q2 Common)

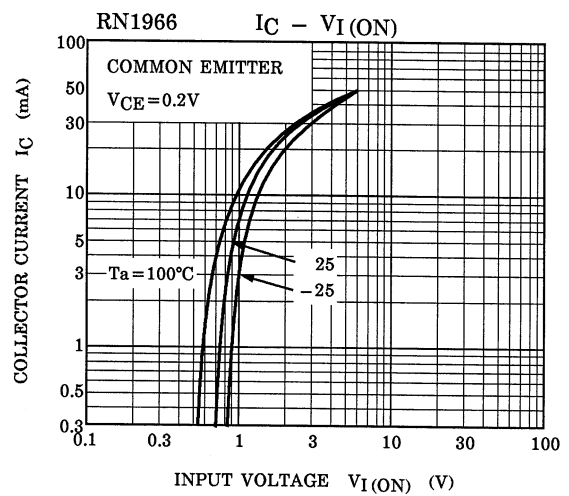
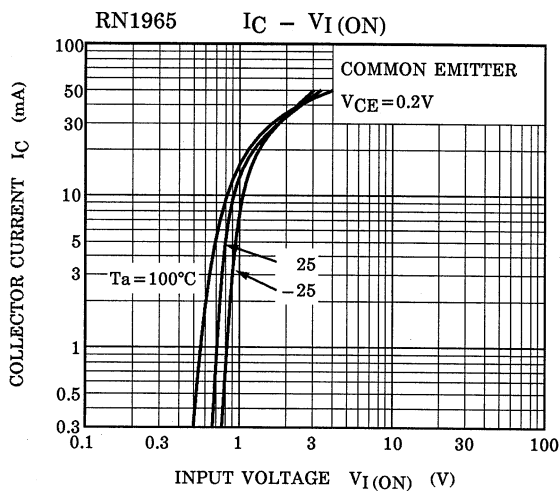
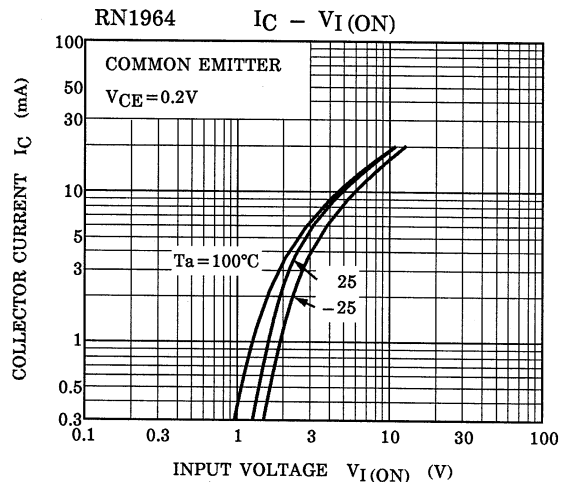
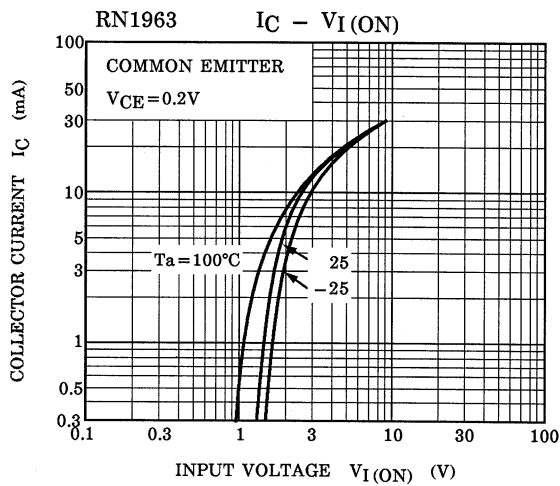
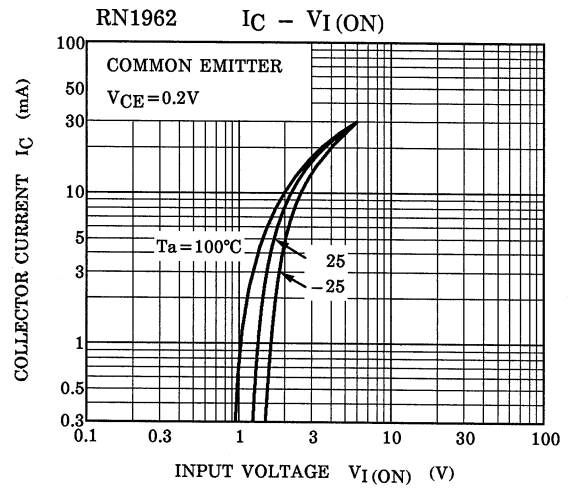
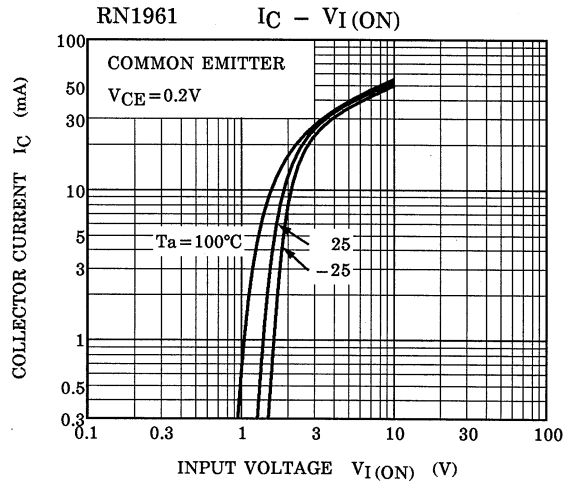

(Q1, Q2 Common)

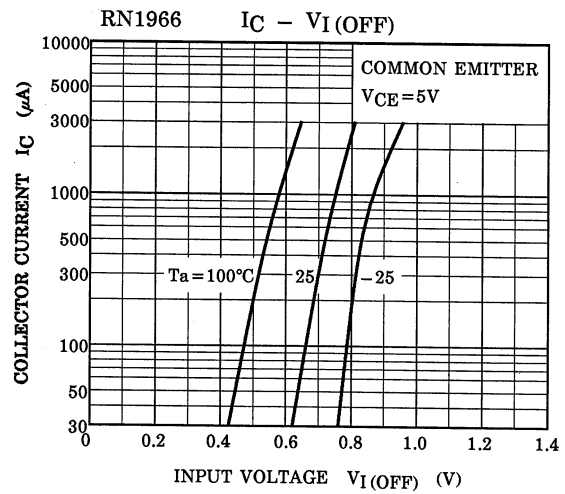
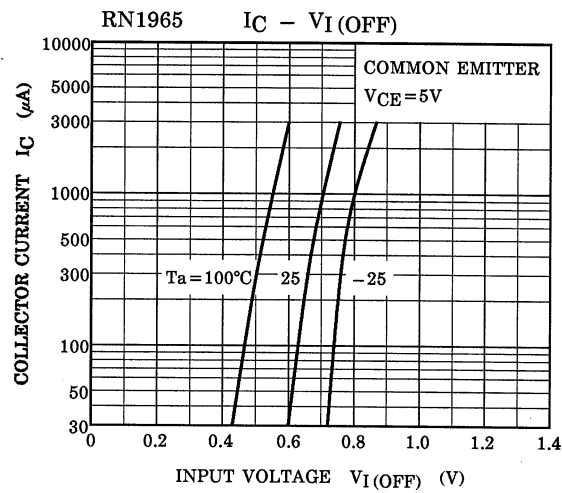
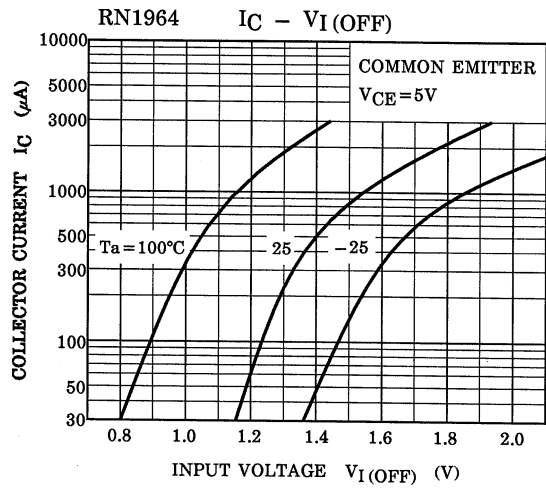
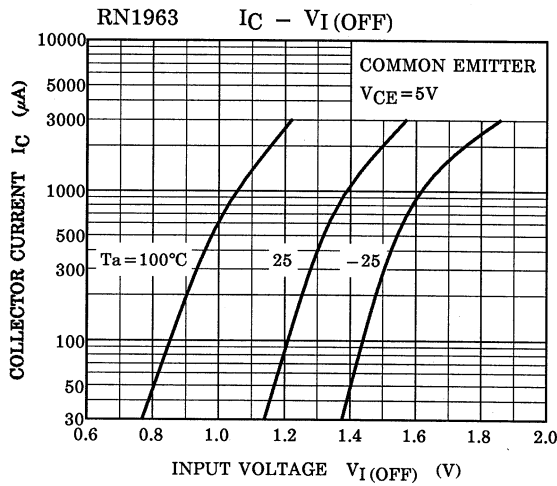
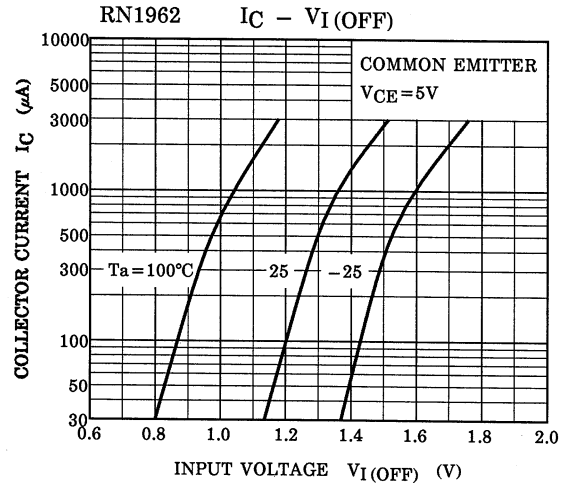
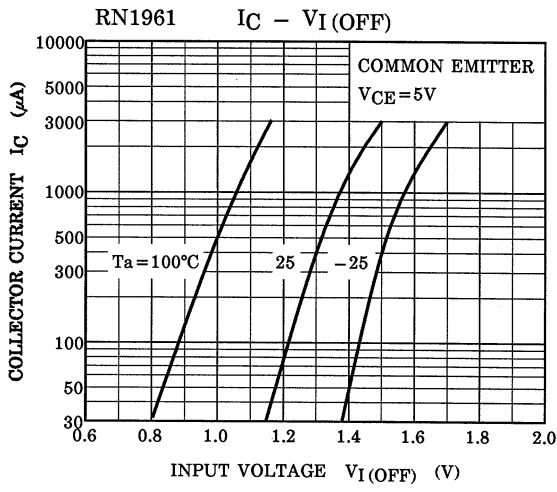

(Q1, Q2 Common)

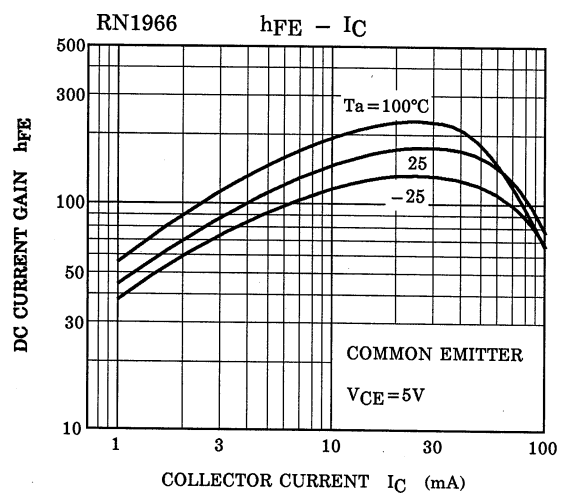
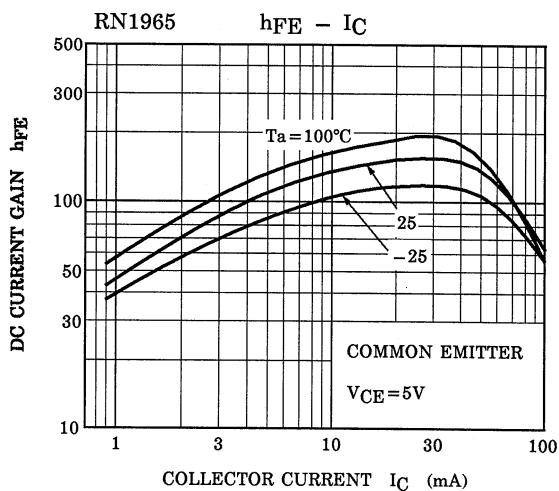
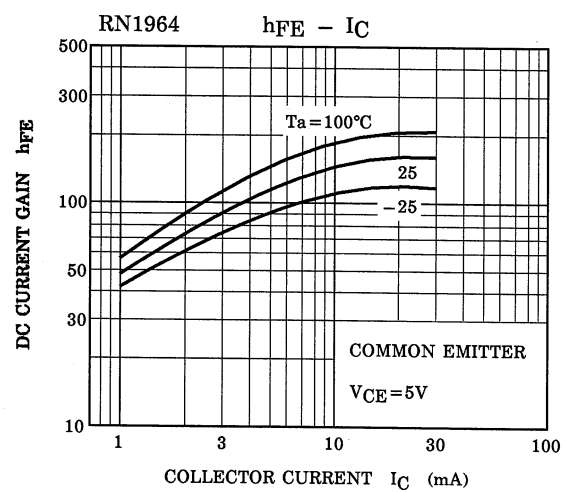
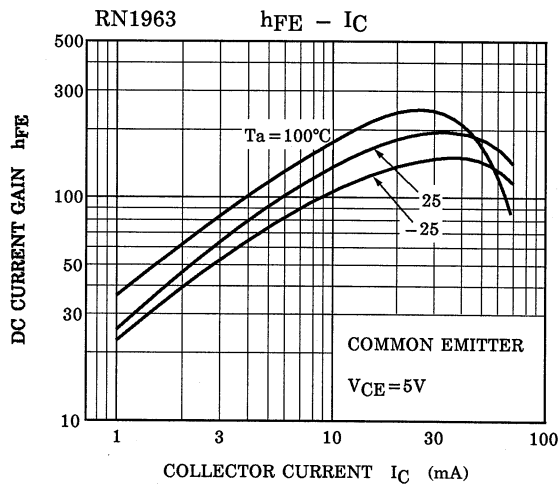
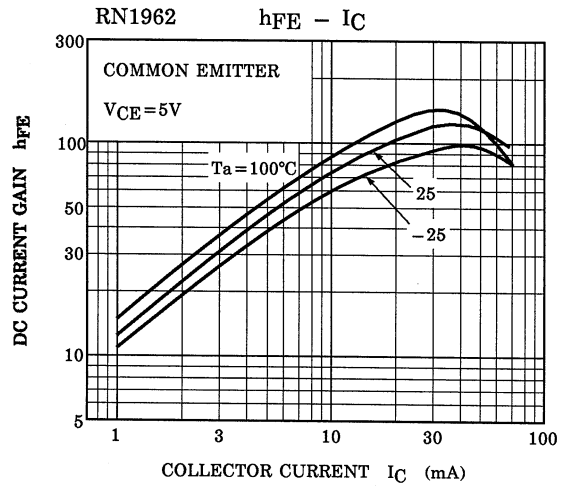
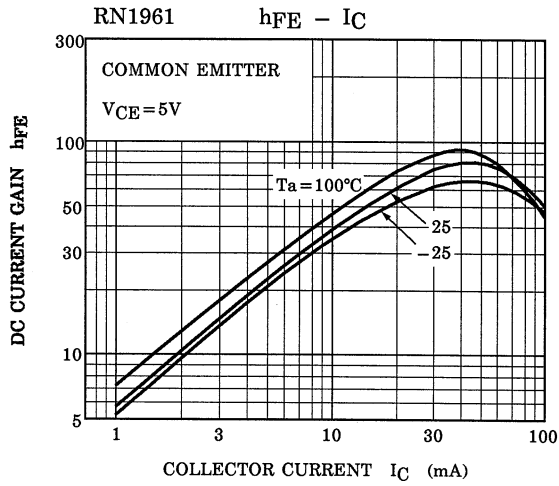

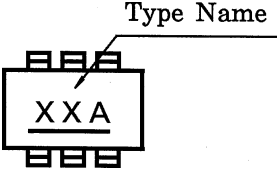
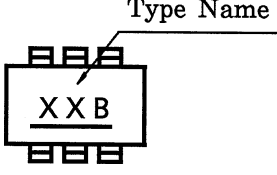
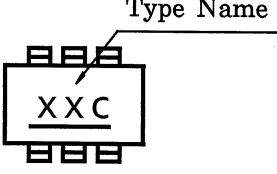
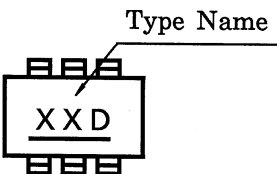
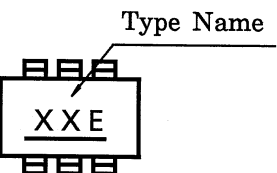
Type Name	Marking
RN1961	
RN1962	
RN1963	
RN1964	
RN1965	
RN1966	