

TOSHIBA Transistor Silicon NPN Epitaxial Type (PCT Process)

RN1967, RN1968, RN1969

Switching, Inverter Circuit, Interface Circuit
And Driver Circuit Applications

- Including two devices in US6 (ultra super mini type 6 leads)
- With built-in bias resistors
- Simplify circuit design
- Reduce a quantity of parts and manufacturing process
- Complementary to RN2967~RN2969

Equivalent Circuit and Bias Resistor Values

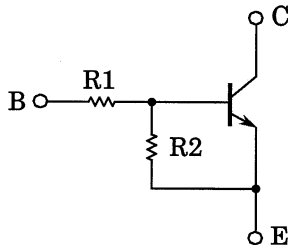

Type No.	R1 (kΩ)	R2 (kΩ)
RN1967	10	47
RN1968	22	47
RN1969	47	22

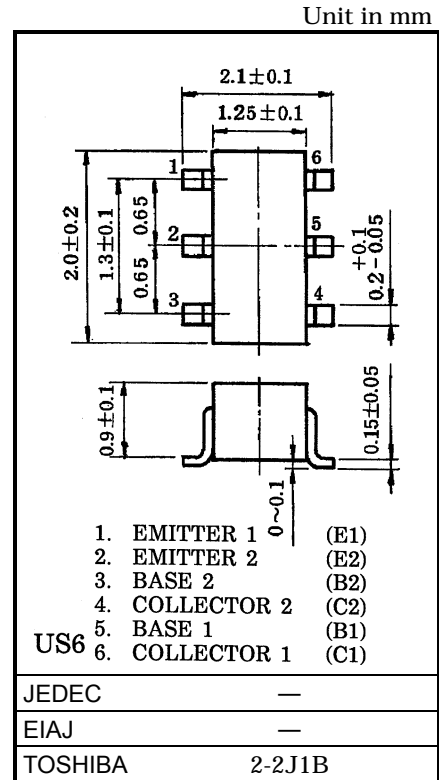

Weight: 6.8mg

Equivalent Circuit (Top View)

Maximum Ratings (Ta = 25°C) (Q1, Q2 Common)

Characteristic	Symbol	Rating	Unit
Collector-base voltage	V_{CB0}	50	V
Collector-emitter voltage	V_{CEO}	50	V
Emitter-base voltage	V_{EBO}	6	V
		7	
		15	
Collector current	I_C	100	mA
Collector power dissipation	P_C^*	200	mW
Junction temperature	T_j	150	°C
Storage temperature range	T_{stg}	-55~150	°C

*: Total rating

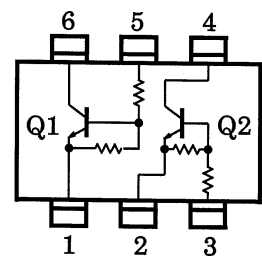

961001EAA2

● TOSHIBA is continually working to improve the quality and the reliability of its products. Nevertheless, semiconductor devices in general can malfunction or fail due to their inherent electrical sensitivity and vulnerability to physical stress. It is the responsibility of the buyer, when utilizing TOSHIBA products, to observe standards of safety, and to avoid situations in which a malfunction or failure of a TOSHIBA product could cause loss of human life, bodily injury or damage to property. In developing your designs, please ensure that TOSHIBA products are used within specified operating ranges as set forth in the most recent products specifications. Also, please keep in mind the precautions and conditions set forth in the TOSHIBA Semiconductor Reliability Handbook.

Electrical Characteristics (Ta = 25°C) (Q1, Q2 Common)

Characteristic	Symbol	Test Circuit	Test Condition	Min	Typ.	Max	Unit	
Collector cut-off current	RN1967~1969	I_{CBO}	—	$V_{CB} = 50V, I_E = 0$	—	—	100	nA
		I_{CEO}	—	$V_{CE} = 50V, I_B = 0$	—	—	500	nA
Emitter cut-off current	RN1967	I_{EBO}	—	$V_{EB} = 6V, I_C = 0$	0.081	—	0.15	mA
	RN1968		—	$V_{EB} = 7V, I_C = 0$	0.078	—	0.145	
	RN1969		—	$V_{EB} = 15V, I_C = 0$	0.167	—	0.311	
DC current gain	RN1967	h_{FE}	—	$V_{CE} = 5V, I_C = 10mA$	80	—	—	—
	RN1968		—		80	—	—	
	RN1969		—		70	—	—	
Collector-emitter saturation voltage	RN1967~1969	$V_{CE(sat)}$	—	$I_C = 5mA, I_B = 0.25mA$	—	0.1	0.3	V
Input voltage (ON)	RN1967	$V_{I(ON)}$	—	$V_{CE} = 0.2V, I_C = 5mA$	0.7	—	1.8	V
	RN1968		—		1.0	—	2.6	
	RN1969		—		2.2	—	5.8	
Input voltage (OFF)	RN1967	$V_{I(OFF)}$	—	$V_{CE} = 5V, I_C = 0.1mA$	0.5	—	1.0	V
	RN1968		—		0.6	—	1.16	
	RN1969		—		1.5	—	2.6	
Transition frequency	RN1967~1969	f_T	—	$V_{CE} = 10V, I_C = 5mA$	—	250	—	MHz
Collector output capacitance	RN1967~1969	C_{ob}	—	$V_{CB} = 10V, I_E = 0$ $f = 1MHz$	—	3	6	pF
Input resistor	RN1967	R1	—	—	7	10	13	kΩ
	RN1968		—		15.4	22	28.6	
	RN1969		—		32.9	47	61.1	
Resistor ratio	RN1967	R1/R2	—	—	0.191	0.213	0.232	—
	RN1968		—		0.421	0.468	0.515	
	RN1969		—		1.92	2.14	2.35	

961001EAA2

- The information contained herein is presented only as a guide for the applications of our products. No responsibility is assumed by TOSHIBA CORPORATION for any infringements of intellectual property or other rights of the third parties which may result from its use. No license is granted by implication or otherwise under any intellectual property or other rights of TOSHIBA CORPORATION or others.
- The information contained herein is subject to change without notice.

(Q1, Q2 Common)

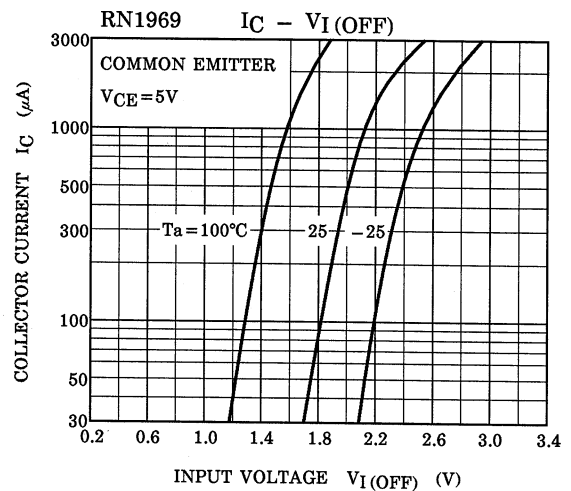
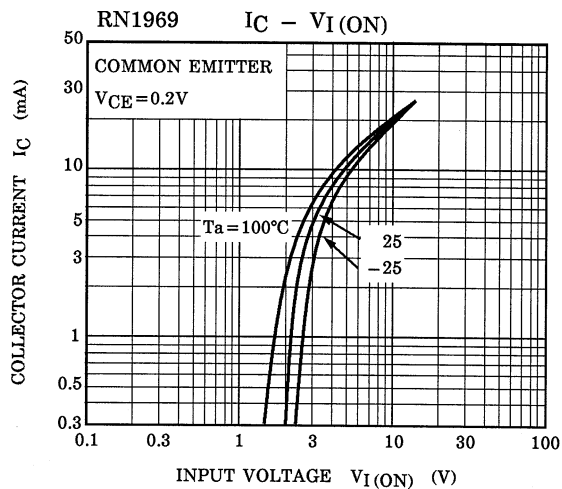
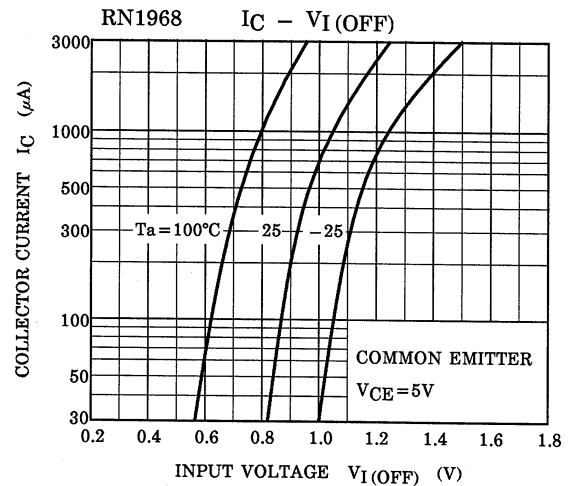
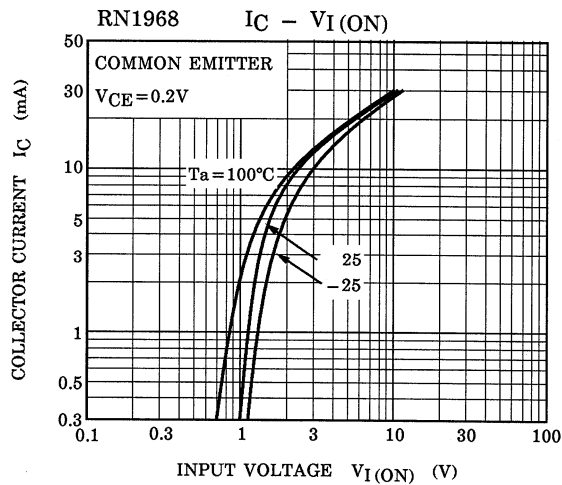
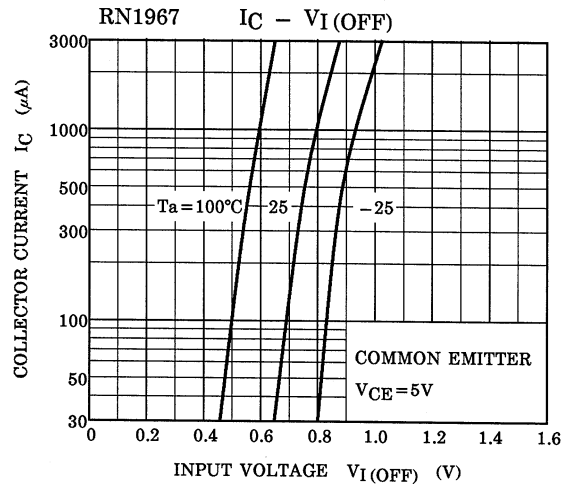
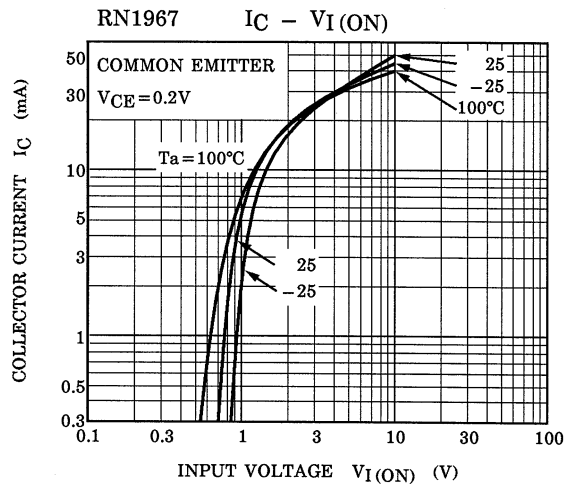

(Q1, Q2 Common)

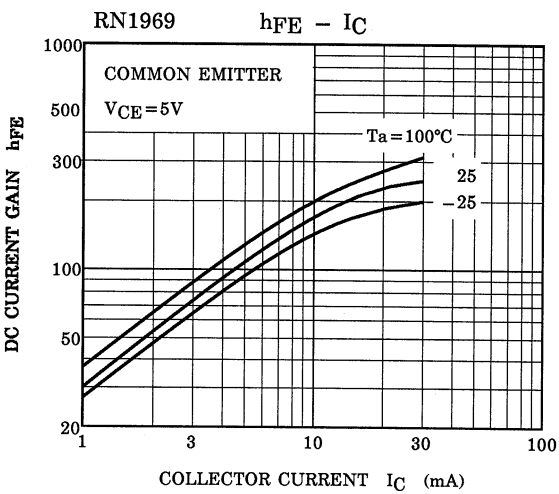
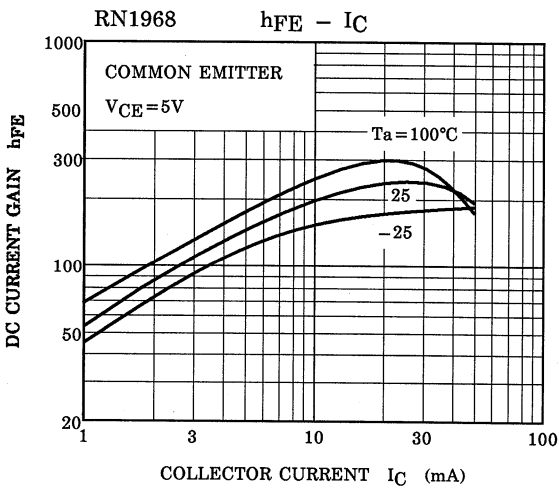
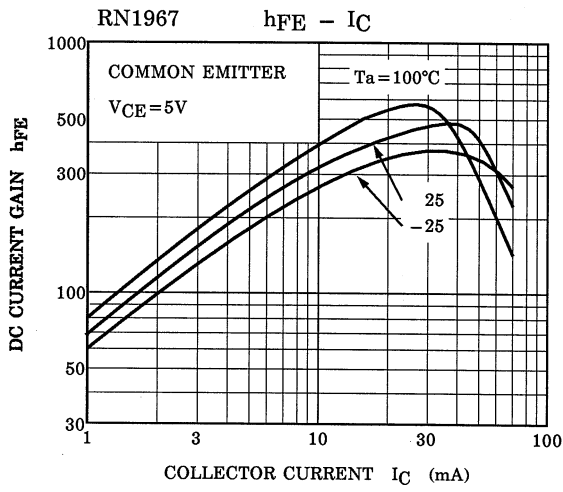

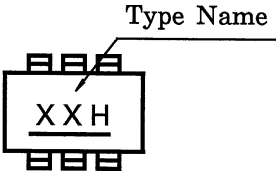
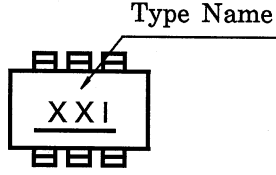
Type Name	Marking
RN1967	
RN1968	
RN1969	