

TOSHIBA Transistor Silicon PNP Epitaxial Type (PCT Process)

RN2101F, RN2102F, RN2103F RN2104F, RN2105F, RN2106F

Switching, Inverter Circuit, Interface Circuit
And Driver Circuit Applications

Unit in mm

- With built-in bias resistors
- Simplify circuit design
- Reduce a quantity of parts and manufacturing process
- Complementary to RN1101F~RN1106F

Equivalent Circuit and Bias Resister Values

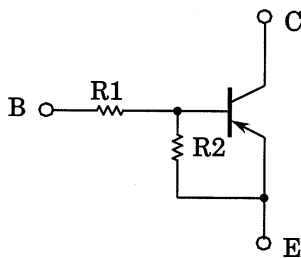

Type No.	R1 (kΩ)	R2 (kΩ)
RN2101F	4.7	4.7
RN2102F	10	10
RN2103F	22	22
RN2104F	47	47
RN2105F	2.2	47
RN2106F	4.7	47

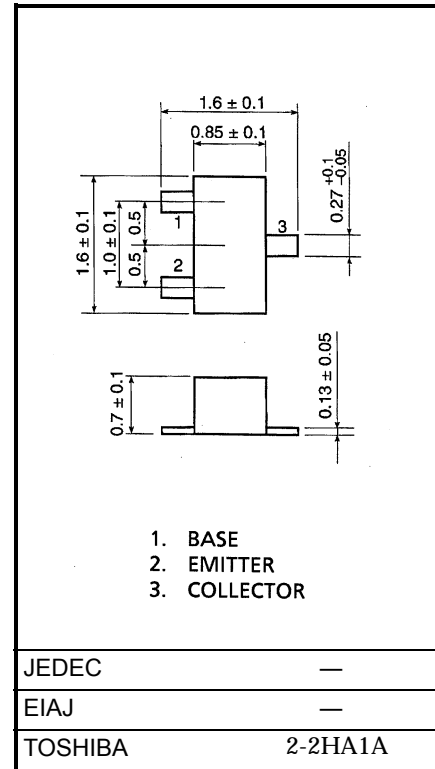

Maximum Ratings (Ta = 25°C)

Characteristic	Symbol	Rating	Unit	
Collector-base voltage	RN2101F~2106F	V_{CBO}	-50	V
Collector-emitter voltage		V_{CEO}	-50	V
Emitter-base voltage	RN2101F~2104F	V_{EBO}	-10	V
	RN2105F, 2106F		-5	
Collector current	RN2101F~2106F	I_C	-100	mA
Collector power dissipation		P_C	100	mW
Junction temperature		T_j	150	°C
Storage temperature range		T_{stg}	-55~150	°C

961001EAA2

- TOSHIBA is continually working to improve the quality and the reliability of its products. Nevertheless, semiconductor devices in general can malfunction or fail due to their inherent electrical sensitivity and vulnerability to physical stress. It is the responsibility of the buyer, when utilizing TOSHIBA products, to observe standards of safety, and to avoid situations in which a malfunction or failure of a TOSHIBA product could cause loss of human life, bodily injury or damage to property. In developing your designs, please ensure that TOSHIBA products are used within specified operating ranges as set forth in the most recent products specifications. Also, please keep in mind the precautions and conditions set forth in the TOSHIBA Semiconductor Reliability Handbook.
- The information contained herein is presented only as a guide for the applications of our products. No responsibility is assumed by TOSHIBA CORPORATION for any infringements of intellectual property or other rights of the third parties which may result from its use. No license is granted by implication or otherwise under any intellectual property or other rights of TOSHIBA CORPORATION or others.
- The information contained herein is subject to change without notice.

Electrical Characteristics (Ta = 25°C)

Characteristic		Symbol	Test Circuit	Test Condition	Min	Typ.	Max	Unit
Collector cut-off current	RN2101F ~2106F	I_{CBO}	—	$V_{CB} = -50V, I_E = 0$	—	—	-100	nA
		I_{CEO}		$V_{CE} = -50V, I_B = 0$	—	—	-500	
Emitter cut-off current	RN2101F	I_{EBO}	—	$V_{EB} = -10V, I_C = 0$	-0.82	—	-1.52	mA
	RN2102F				-0.38	—	-0.71	
	RN2103F				-0.17	—	-0.33	
	RN2104F			-0.082	—	-0.15		
	RN2105F			$V_{EB} = -5V, I_C = 0$	-0.078	—	-0.145	
	RN2106F				-0.074	—	-0.138	
DC current gain	RN2101F	h_{FE}	—	$V_{CE} = -5V,$ $I_C = -10mA$	30	—	—	
	RN2102F				50	—	—	
	RN2103F				70	—	—	
	RN2104F				80	—	—	
	RN2105F				80	—	—	
	RN2106F				80	—	—	
Collector-emitter saturation voltage	RN2101F ~2106F	$V_{CE(sat)}$	—	$I_C = -5mA,$ $I_B = -0.25mA$	—	-0.1	-0.3	V
Input voltage (ON)	RN2101F	$V_{I(ON)}$	—	$V_{CE} = -0.2V,$ $I_C = -5mA$	-1.1	—	-2.0	V
	RN2102F				-1.2	—	-2.4	
	RN2103F				-1.3	—	-3.0	
	RN2104F				-1.5	—	-5.0	
	RN2105F				-0.6	—	-1.1	
	RN2106F				-0.7	—	-1.3	
Input voltage (OFF)	RN2101F ~2104F	$V_{I(OFF)}$	—	$V_{CE} = -5V,$ $I_C = -0.1mA$	-1.0	—	-1.5	V
	RN2105F, 2106F				-0.5	—	-0.8	
Transition frequency	RN2101F ~2106F	f_T	—	$V_{CE} = -10V,$ $I_C = -5mA$	—	200	—	MHz
Collector Output capacitance	RN2101F ~2106F	C_{ob}	—	$V_{CB} = -10V, I_E = 0,$ $f = 1MHz$	—	3	6	pF
Input resistor	RN2101F	R1	—		3.29	4.7	6.11	kΩ
	RN2102F				7	10	13	
	RN2103F				15.4	22	28.6	
	RN2104F				32.9	47	61.1	
	RN2105F				1.54	2.2	2.86	
	RN2106F				3.29	4.7	6.11	
Resistor ratio	RN2101F ~2104F	R1/R2	—		0.9	1.0	1.1	
	RN2105F				0.0421	0.0468	0.0515	
	RN2106F				0.09	0.1	0.11	

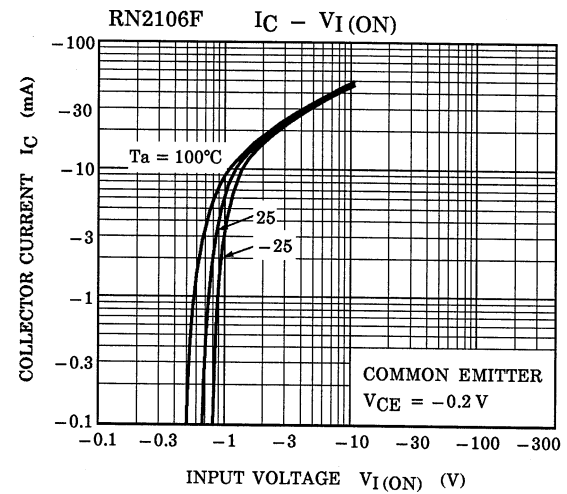
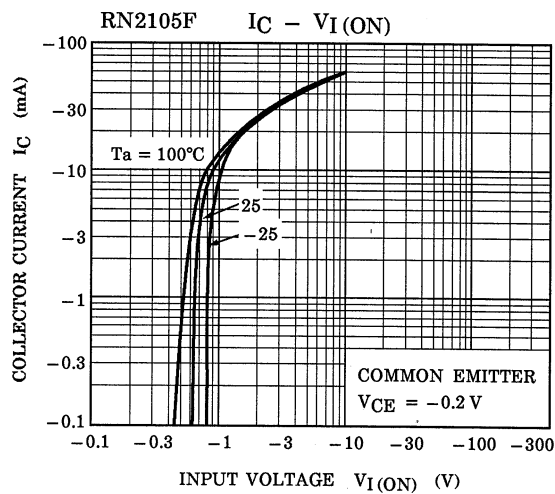
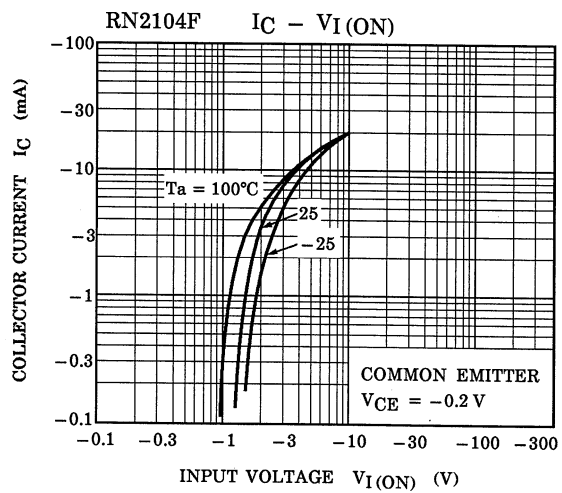
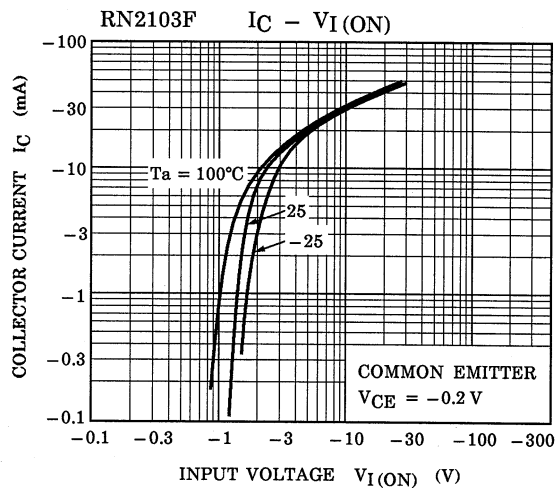
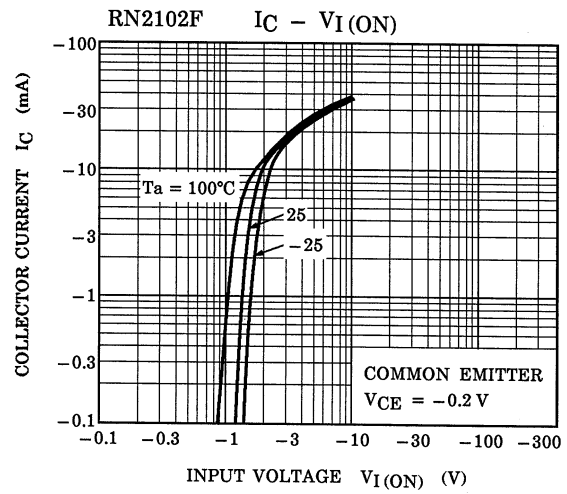
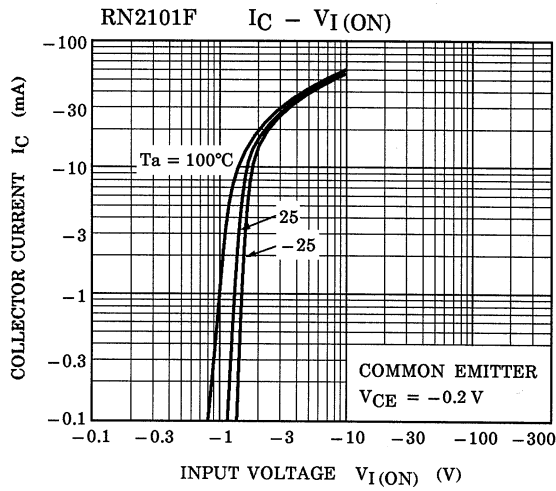

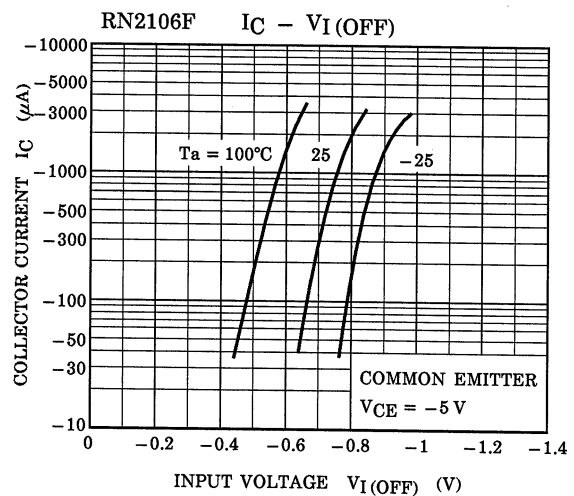
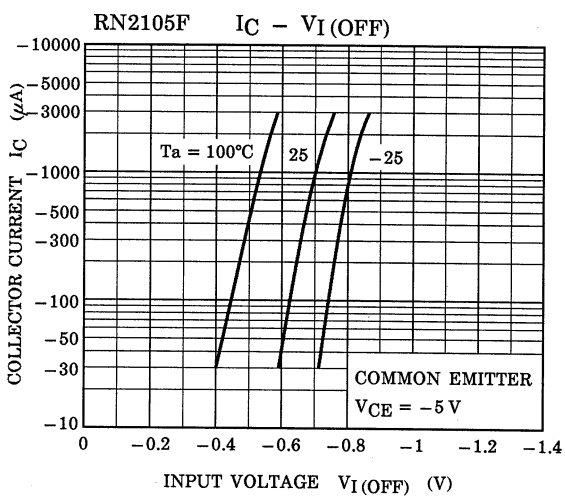
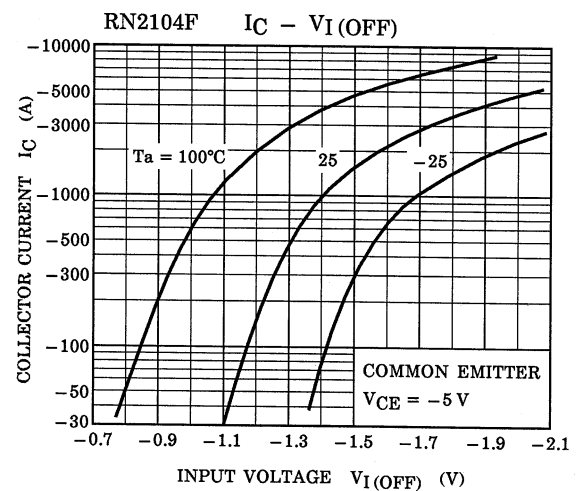
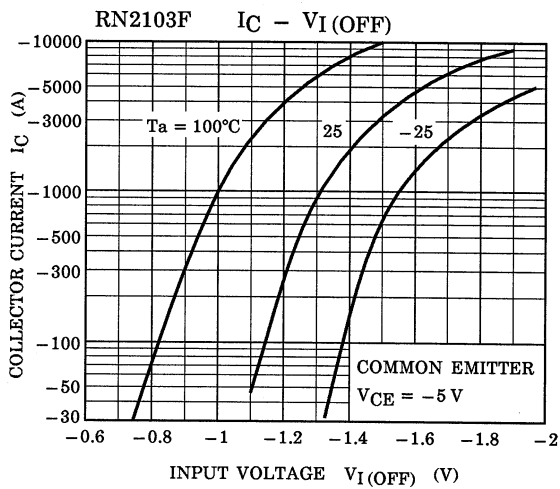
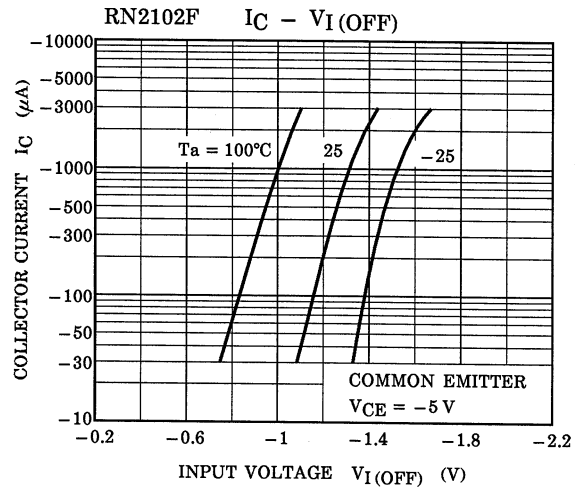
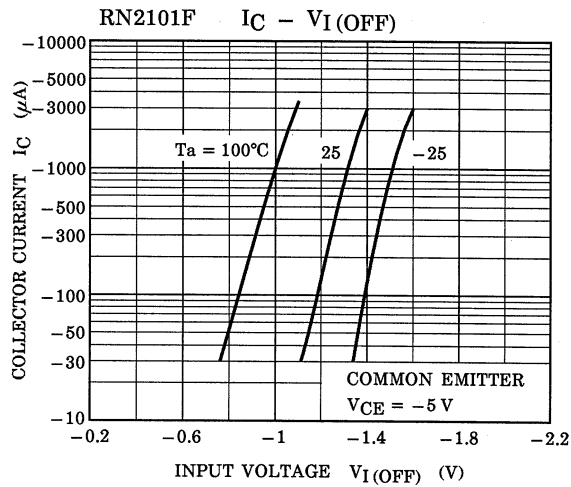

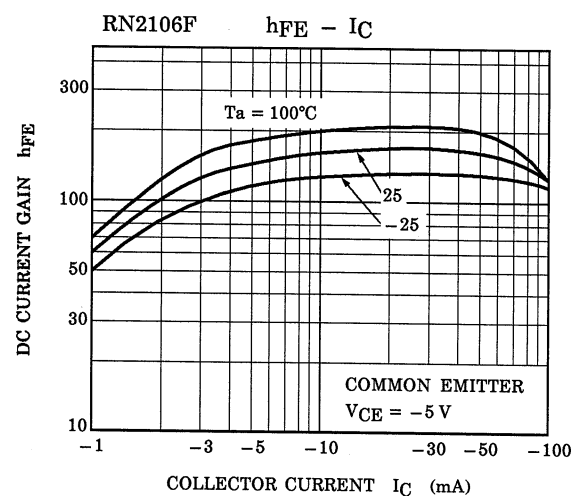
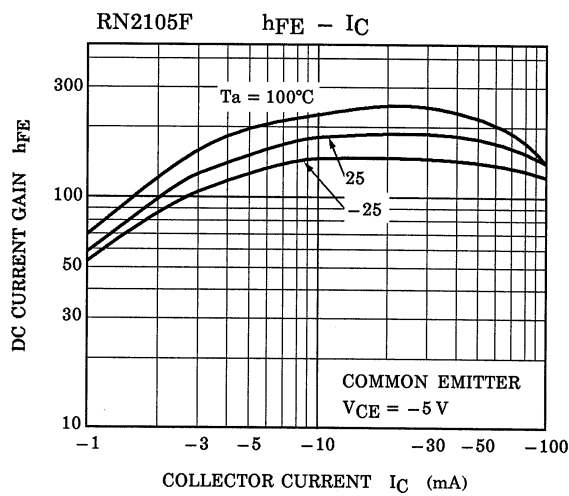
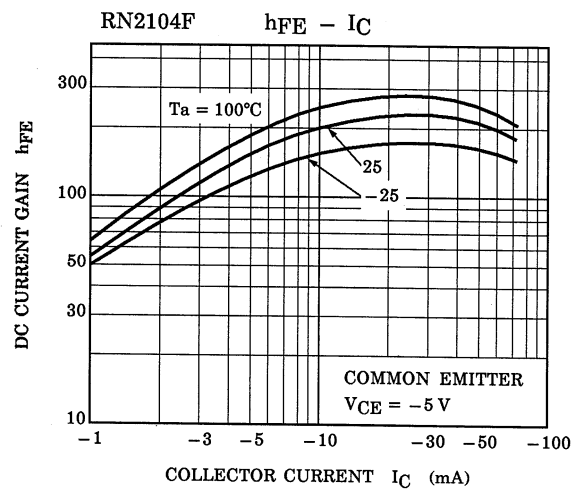
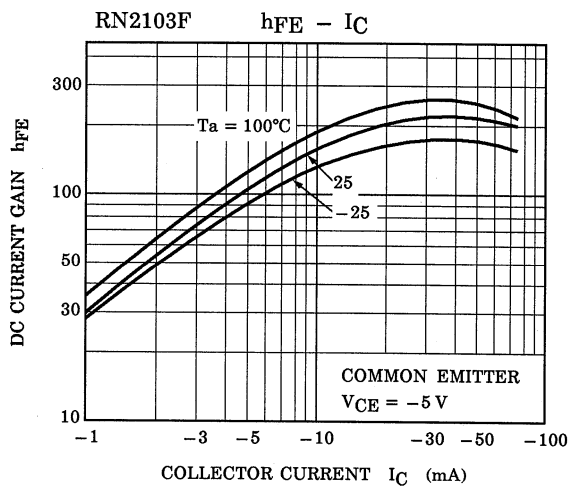
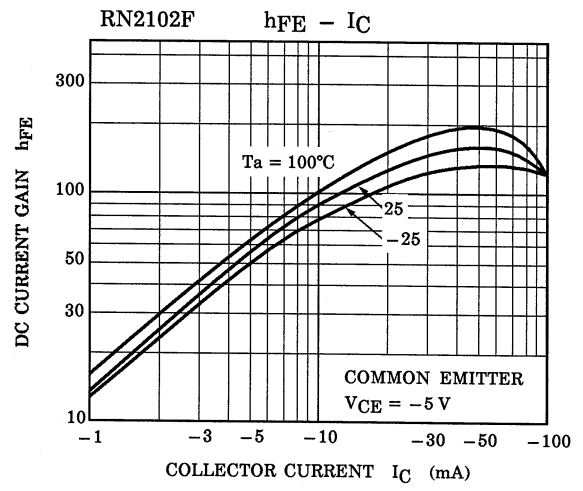
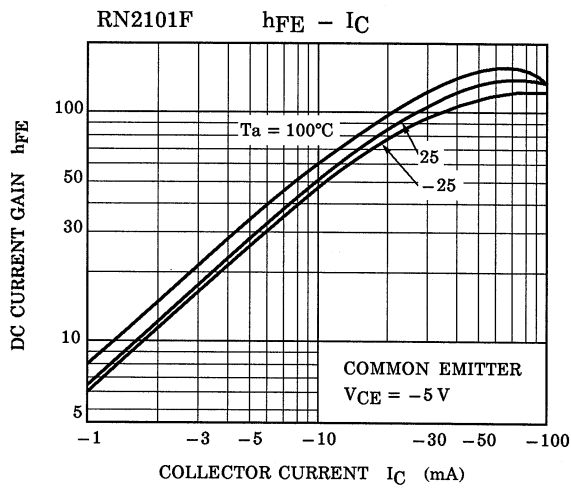

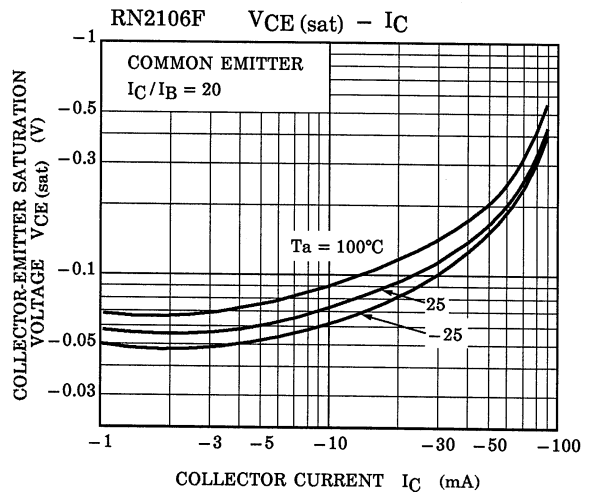
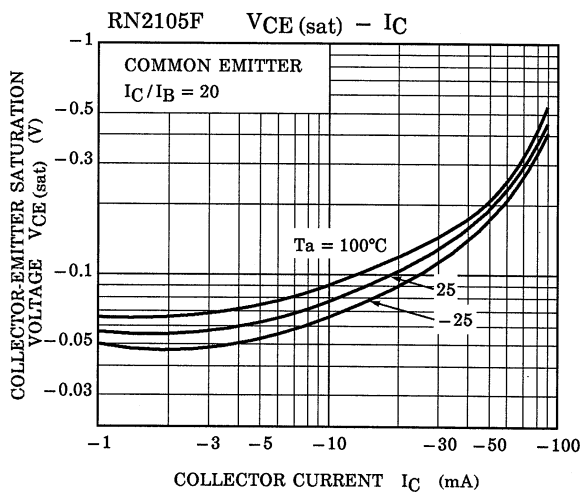
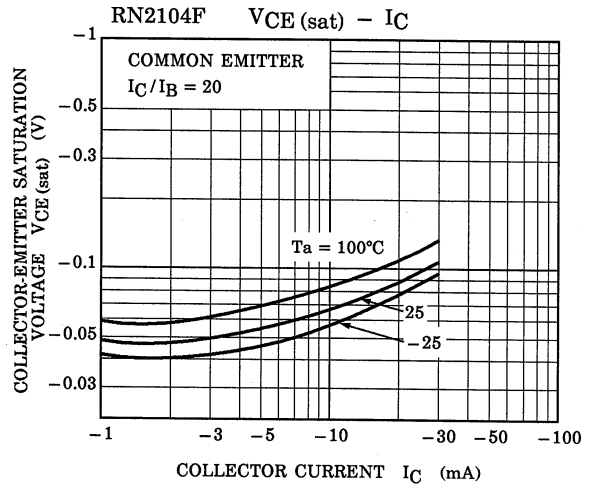
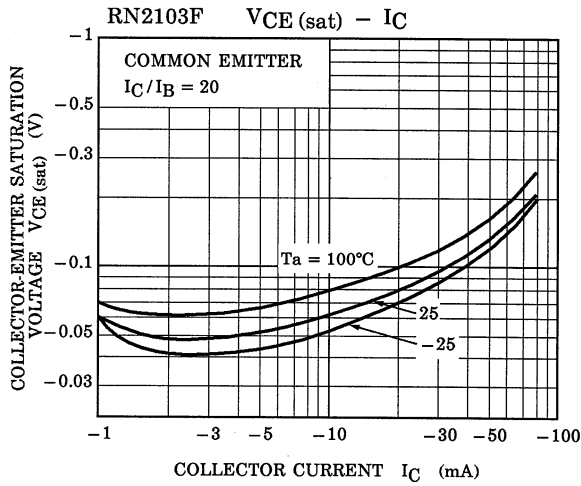
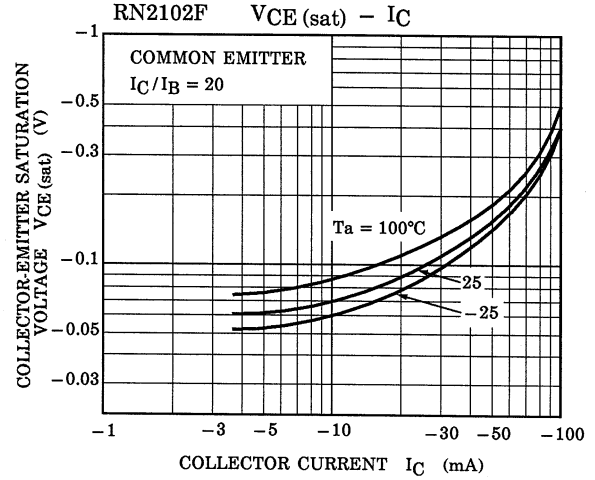
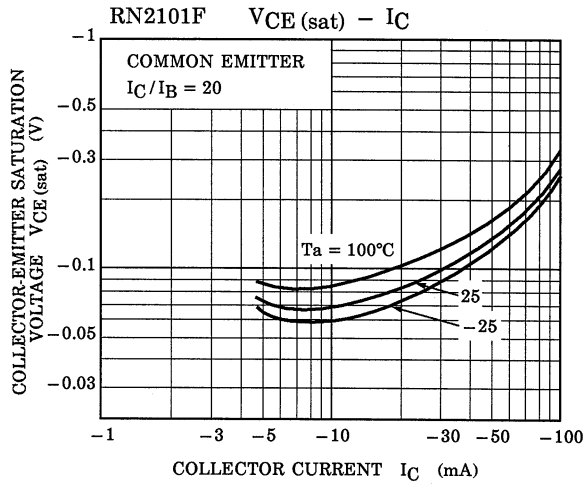

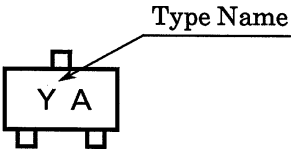
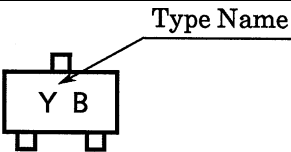
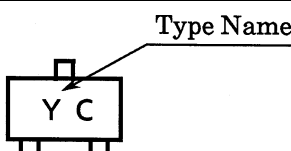
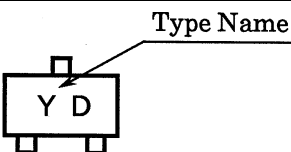
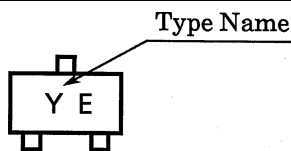
Type Name	Marking
RN2101F	
RN2102F	
RN2103F	
RN2104F	
RN2105F	
RN2106F	