

TOSHIBA Transistor Silicon PNP Epitaxial Type (PCT Process)

RN2107, RN2108, RN2109

Switching, Inverter Circuit, Interface Circuit and Driver Circuit Applications

Unit in mm

- With built-in bias resistors
- Simplify circuit design
- Reduce a quantity of parts and manufacturing process
- Complementary to RN1107~RN1109

Equivalent Circuit and Bias Resister Values

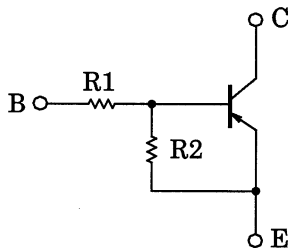

Type No.	R1 (kΩ)	R2 (kΩ)
RN2107	10	47
RN2108	22	47
RN2109	47	22

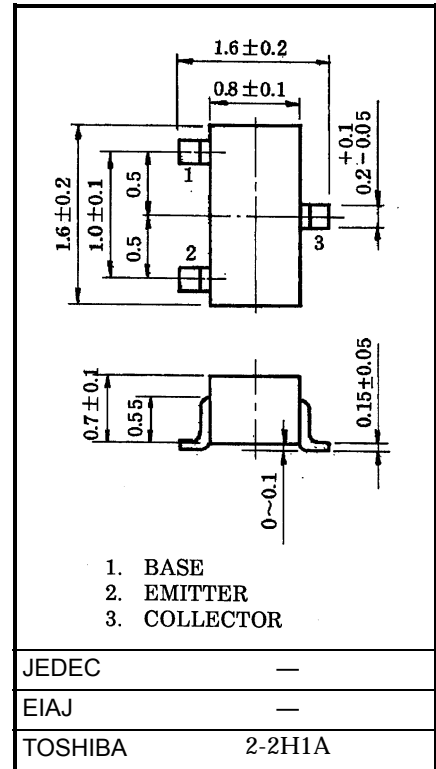

Weight: 2.4mg

Maximum Ratings (Ta = 25°C) (Q1, Q2 Common)

Characteristic	Symbol	Rating	Unit		
Collector-base voltage	RN2107~RN2109	V_{CB0}	-50	V	
Collector-emitter voltage		V_{CE0}	-50	V	
Emitter-base voltage	RN2107	V_{EB0}	-6	V	
			RN2108		-7
			RN2109		-15
Collector current	RN2107~RN2109	I_C	-100	mA	
Collector power dissipation		P_{C^*}	100	mW	
Junction temperature		T_j	150	°C	
Storage temperature range		T_{stg}	-55~150	°C	

*: Total rating

961001EAA2

• TOSHIBA is continually working to improve the quality and the reliability of its products. Nevertheless, semiconductor devices in general can malfunction or fail due to their inherent electrical sensitivity and vulnerability to physical stress. It is the responsibility of the buyer, when utilizing TOSHIBA products, to observe standards of safety, and to avoid situations in which a malfunction or failure of a TOSHIBA product could cause loss of human life, bodily injury or damage to property. In developing your designs, please ensure that TOSHIBA products are used within specified operating ranges as set forth in the most recent products specifications. Also, please keep in mind the precautions and conditions set forth in the TOSHIBA Semiconductor Reliability Handbook.

• The information contained herein is presented only as a guide for the applications of our products. No responsibility is assumed by TOSHIBA CORPORATION for any infringements of intellectual property or other rights of the third parties which may result from its use. No license is granted by implication or otherwise under any intellectual property or other rights of TOSHIBA CORPORATION or others.

• The information contained herein is subject to change without notice.

Electrical Characteristics (Ta = 25°C) (Q1, Q2 Common)

Characteristic		Symbol	Test Circuit	Test Condition	Min	Typ.	Max	Unit
Collector cut-off current	RN2107 ~RN2109	I_{CBO}	—	$V_{CB} = -50V, I_E = 0$	—	—	-100	nA
		I_{CEO}		$V_{CE} = -50V, I_B = 0$	—	—	-500	nA
Emitter cut-off current	RN2107	I_{EBO}	—	$V_{EB} = -6V, I_C = 0$	-0.081	—	-0.15	mA
	RN2108			$V_{EB} = -7V, I_C = 0$	-0.078	—	-0.145	
	RN2109			$V_{EB} = -15V, I_C = 0$	-0.167	—	-0.311	
DC current gain	RN2107	h_{FE}	—	$V_{CE} = -5V, I_C = -10mA$	80	—	—	—
	RN2108				80	—	—	
	RN2109				70	—	—	
Collector-emitter saturation voltage	RN2107 ~RN2109	$V_{CE(sat)}$	—	$I_C = -5mA, I_B = -0.25mA$	—	-0.1	-0.3	V
Input voltage (ON)	RN2107	$V_{I(ON)}$	—	$V_{CE} = -0.2V, I_C = -5mA$	-0.7	—	-1.8	V
	RN2108				-1.0	—	-2.6	
	RN2109				-2.2	—	-5.8	
Input voltage (OFF)	RN2107	$V_{I(OFF)}$	—	$V_{CE} = -5V, I_C = -0.1mA$	-0.5	—	-1.0	V
	RN2108				-0.6	—	-1.16	
	RN2109				-1.5	—	-2.6	
Transition frequency	RN2107 ~RN2109	f_T	—	$V_{CE} = -10V, I_C = -5mA$	—	200	—	MHz
Collector Output capacitance	RN2107 ~RN2109	C_{ob}	—	$V_{CB} = -10V, I_E = 0, f = 1MHz$	—	3	6	pF
Input resistor	RN2107	R1	—	—	7	10	13	kΩ
	RN2108				15.4	22	28.6	
	RN2109				32.9	47	61.1	
Resistor ratio	RN2107	R1/R2	—	—	0.191	0.213	0.232	—
	RN2108				0.421	0.468	0.515	
	RN2109				1.92	2.14	2.35	

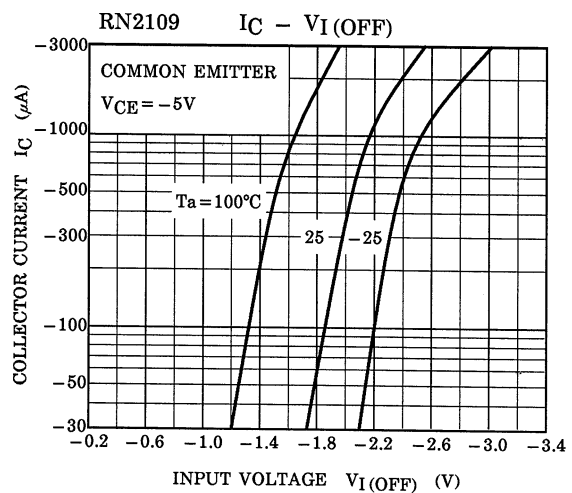
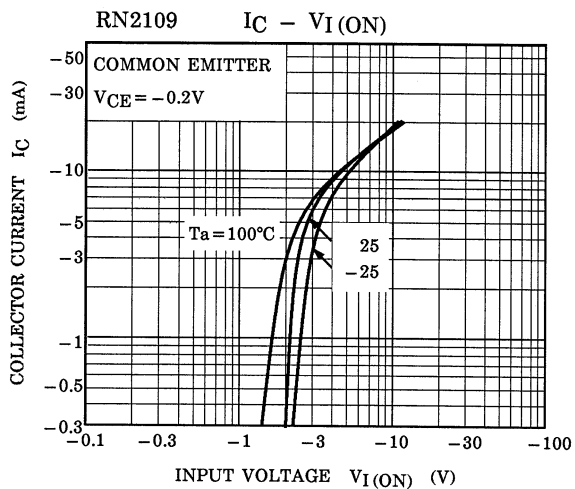
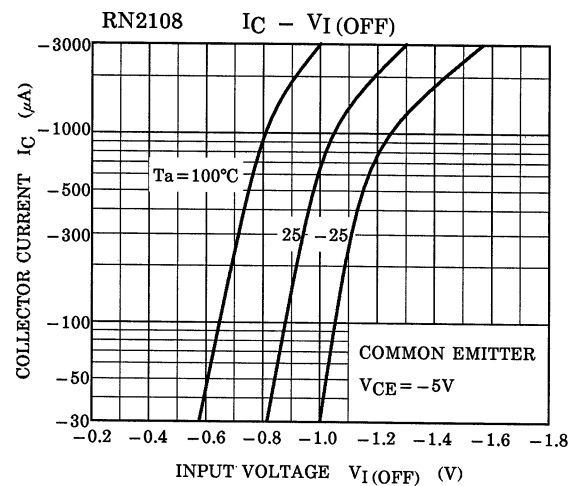
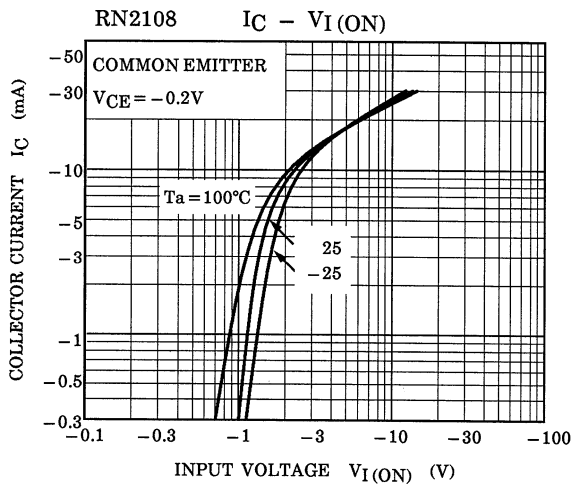
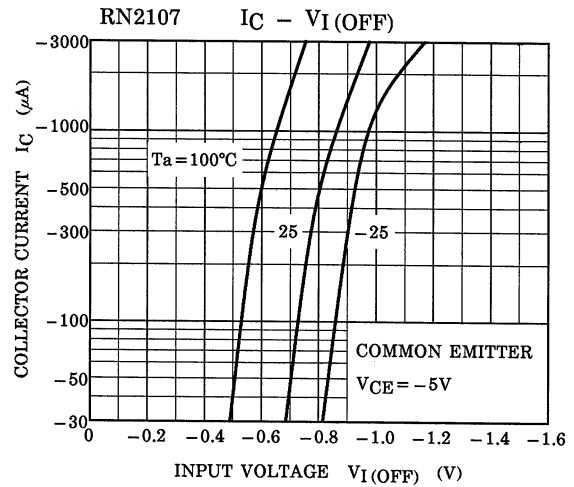
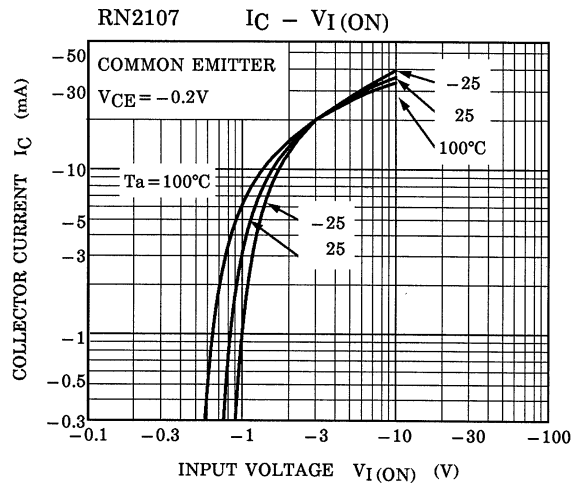

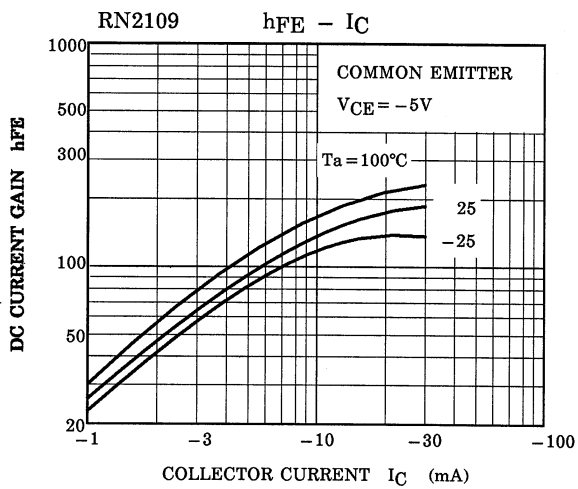
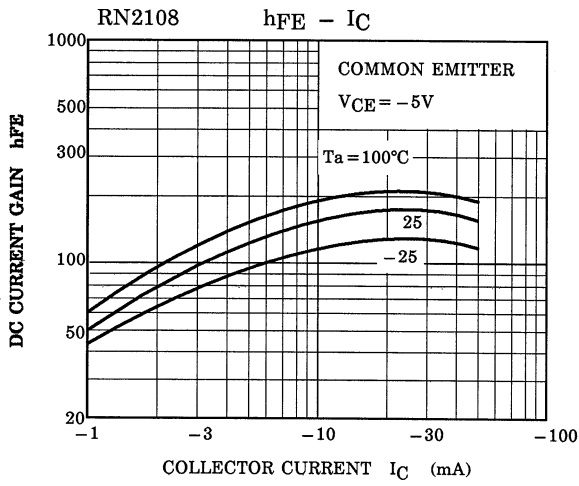
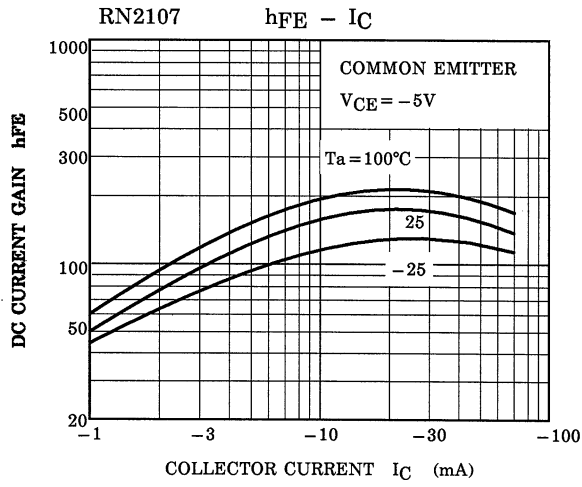

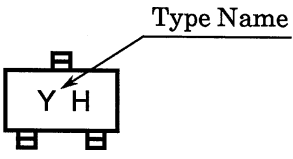
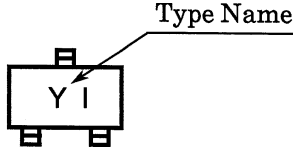
Type Name	Marking
RN2107	
RN2108	
RN2109	