

TOSHIBA Transistor Silicon PNP Epitaxial Type (PCT Process)

RN2110,RN2111

Switching, Inverter Circuit, Interface Circuit and Driver Circuit Applications

- With built-in bias resistors
- Simplify circuit design
- Reduce a quantity of parts and manufacturing process
- Complementary to RN1110, RN1111

Equivalent Circuit

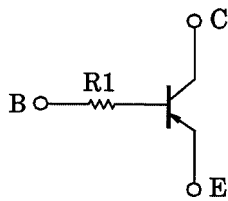

Maximum Ratings (Ta = 25°C)

Characteristic	Symbol	Rating	Unit
Collector-base voltage	V_{CBO}	-50	V
Collector-emitter voltage	V_{CEO}	-50	V
Emitter-base voltage	V_{EBO}	-5	V
Collector current	I_C	-100	mA
Collector power dissipation	P_C	100	mW
Junction temperature	T_j	150	°C
Storage temperature range	T_{stg}	-55~150	°C

Electrical Characteristics (Ta = 25°C)

Characteristic	Symbol	Test Circuit	Test Condition	Min	Typ.	Max	Unit
Collector cut-off current	I_{CBO}	—	$V_{CB} = -50V, I_E = 0$	—	—	-100	nA
Emitter cut-off current	I_{EBO}	—	$V_{EB} = -5V, I_C = 0$	—	—	-100	nA
DC current gain	h_{FE}	—	$V_{CE} = -5V, I_C = -1mA$	120	—	400	—
Collector-emitter saturation voltage	$V_{CE(sat)}$	—	$I_C = -5mA, I_B = -0.25mA$	—	-0.1	-0.3	V
Transition frequency	f_T	—	$V_{CE} = -10V, I_C = -5mA$	—	200	—	MHz
Collector output capacitance	C_{ob}	—	$V_{CB} = -10V, I_E = 0, f = 1MHz$	—	3	6	pF
Input resistor	RN2110	R1	—	3.29	4.7	6.11	kΩ
	RN2111			7	10	13	

961001EAA2

- TOSHIBA is continually working to improve the quality and the reliability of its products. Nevertheless, semiconductor devices in general can malfunction or fail due to their inherent electrical sensitivity and vulnerability to physical stress. It is the responsibility of the buyer, when utilizing TOSHIBA products, to observe standards of safety, and to avoid situations in which a malfunction or failure of a TOSHIBA product could cause loss of human life, bodily injury or damage to property. In developing your designs, please ensure that TOSHIBA products are used within specified operating ranges as set forth in the most recent products specifications. Also, please keep in mind the precautions and conditions set forth in the TOSHIBA Semiconductor Reliability Handbook.
- The information contained herein is presented only as a guide for the applications of our products. No responsibility is assumed by TOSHIBA CORPORATION for any infringements of intellectual property or other rights of the third parties which may result from its use. No license is granted by implication or otherwise under any intellectual property or other rights of TOSHIBA CORPORATION or others.
- The information contained herein is subject to change without notice.

Unit in mm

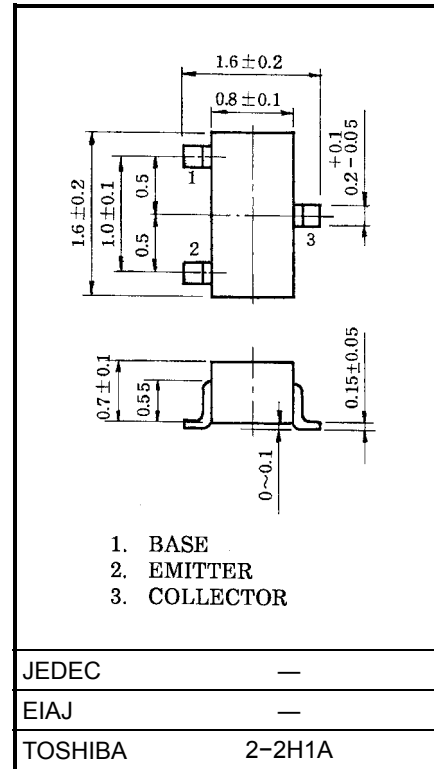

Weight: 2.4mg

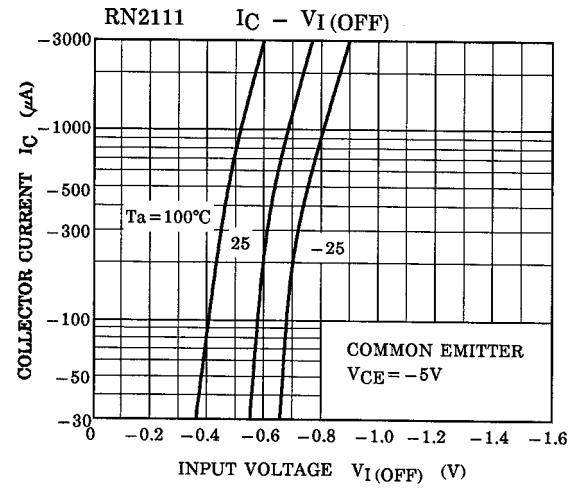
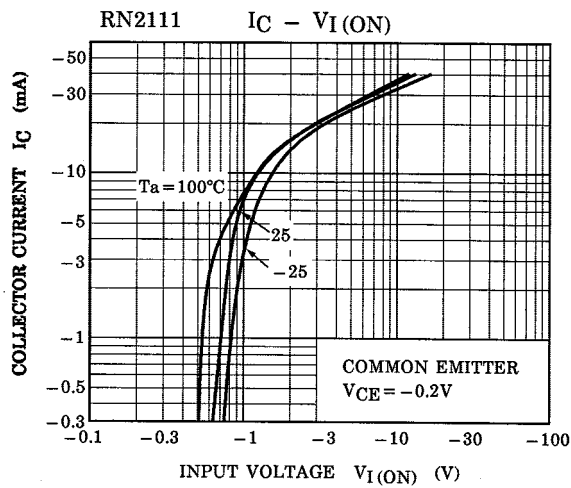
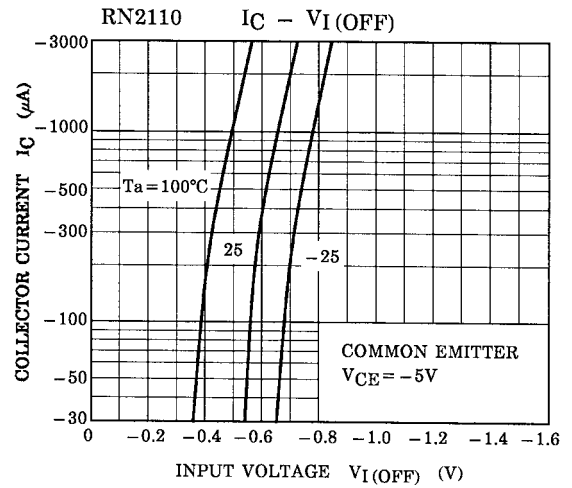
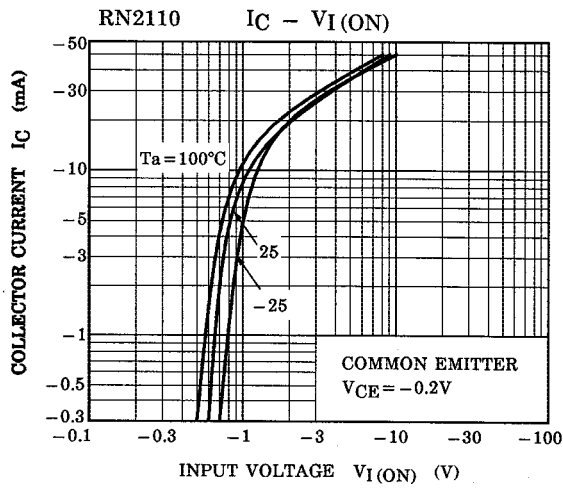

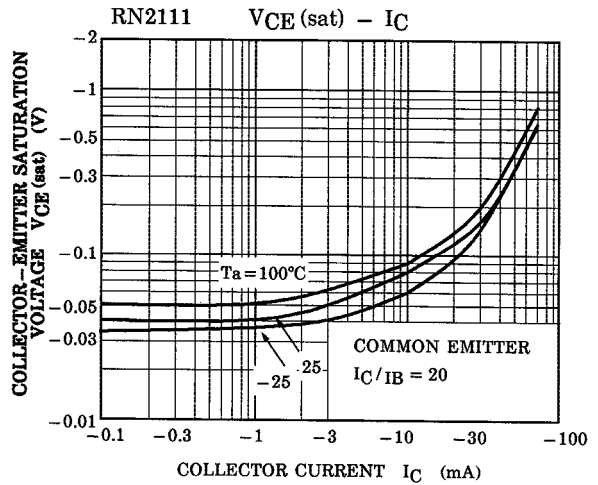
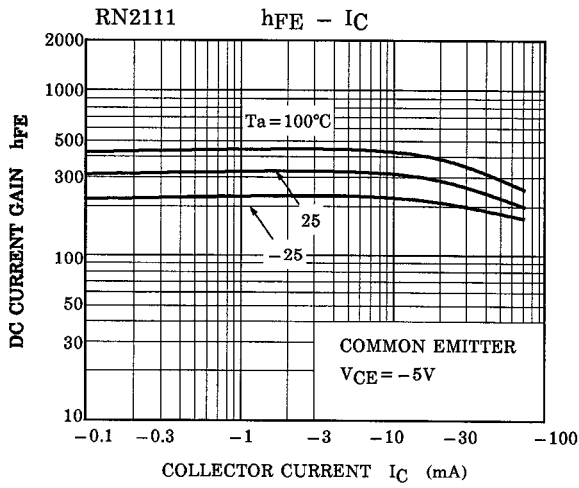
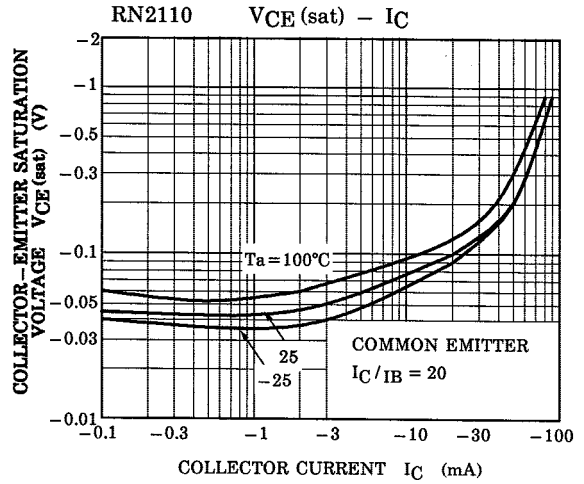
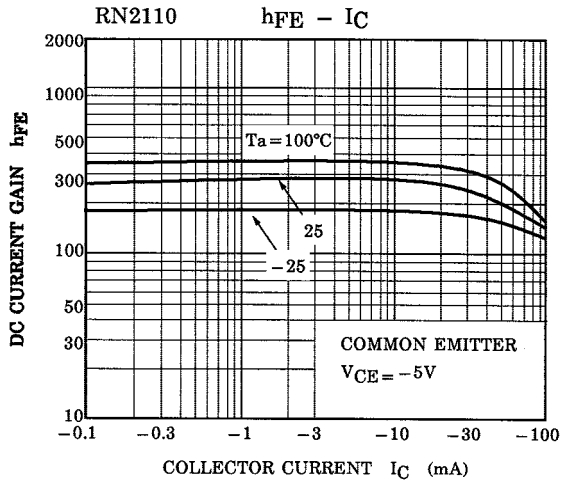

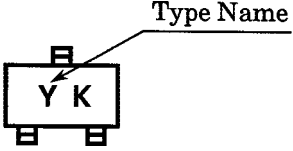
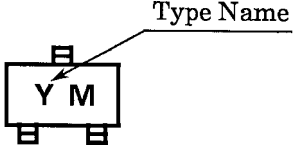
Type Name	Marking
RN2110	 <p>The diagram shows a rectangular component with four pins. The top pin is labeled with a small square symbol. The bottom two pins are also labeled with small square symbols. The letters 'Y K' are printed inside the rectangle. A line points from the text 'Type Name' to the 'Y' character.</p>
RN2111	 <p>The diagram shows a rectangular component with four pins. The top pin is labeled with a small square symbol. The bottom two pins are also labeled with small square symbols. The letters 'Y M' are printed inside the rectangle. A line points from the text 'Type Name' to the 'Y' character.</p>