

TOSHIBA Transistor Silicon PNP Epitaxial Type (PCT Process)

RN2301, RN2302, RN2303 RN2304, RN2305, RN2306

Switching, Inverter Circuit, Interface Circuit
And Driver Circuit Applications

Unit in mm

- With built-in bias resistors
- Simplify circuit design
- Reduce a quantity of parts and manufacturing process
- Complementary to RN1301~1306

Equivalent Circuit

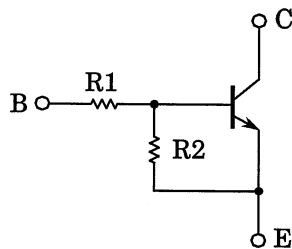

Bias Resistor Values

Type No.	R1 (kΩ)	R2 (kΩ)
RN2301	4.7	4.7
RN2302	10	10
RN2303	22	22
RN2304	47	47
RN2305	2.2	47
RN2306	4.7	47

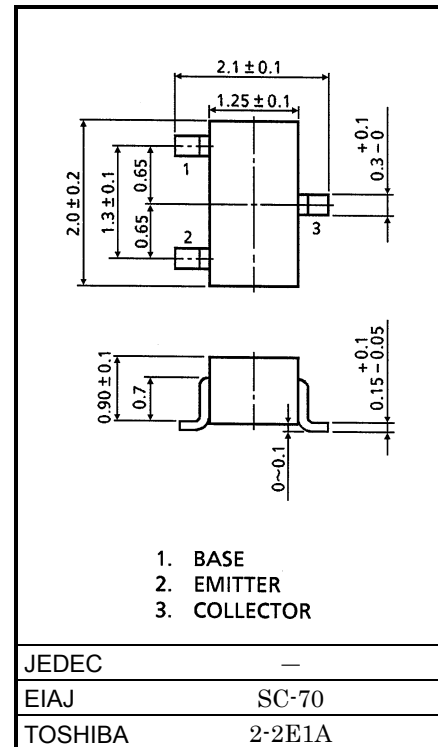

JEDEC	—
EIAJ	SC-70
TOSHIBA	2-2E1A

Weight: 0.006g

Maximum Ratings (Ta = 25°C)

Characteristic	Symbol	Rating	Unit
Collector-base voltage	V_{CB0}	-50	V
Collector-emitter voltage	V_{CEO}	-50	V
Emitter-base voltage	V_{EBO}	-10	V
		-5	
Collector current	I_C	-100	mA
Collector power dissipation	P_C	100	mW
Junction temperature	T_j	150	°C
Storage temperature range	T_{stg}	-55~150	°C

961001EAA1

- TOSHIBA is continually working to improve the quality and the reliability of its products. Nevertheless, semiconductor devices in general can malfunction or fail due to their inherent electrical sensitivity and vulnerability to physical stress. It is the responsibility of the buyer, when utilizing TOSHIBA products, to observe standards of safety, and to avoid situations in which a malfunction or failure of a TOSHIBA product could cause loss of human life, bodily injury or damage to property. In developing your designs, please ensure that TOSHIBA products are used within specified operating ranges as set forth in the most recent products specifications. Also, please keep in mind the precautions and conditions set forth in the TOSHIBA Semiconductor Reliability Handbook.
- The information contained herein is presented only as a guide for the applications of our products. No responsibility is assumed by TOSHIBA CORPORATION for any infringements of intellectual property or other rights of the third parties which may result from its use. No license is granted by implication or otherwise under any intellectual property or other rights of TOSHIBA CORPORATION or others.
- The information contained herein is subject to change without notice.

Electrical Characteristics (Ta = 25°C)

Characteristic		Symbol	Test Circuit	Test Condition	Min	Typ.	Max	Unit
Collector cut-off current	RN2301~2306	I_{CBO}	—	$V_{CB} = -50V, I_E = 0$	—	—	-100	nA
		I_{CEO}	—	$V_{CE} = -50V, I_B = 0$	—	—	-500	
Emitter cut-off current	RN2301	I_{EBO}	—	$V_{EB} = -10V, I_C = 0$	-0.82	—	-1.52	mA
	RN2302		—		-0.38	—	-0.71	
	RN2303		—		-0.17	—	-0.33	
	RN2304		—	-0.082	—	-0.15		
	RN2305		—	$V_{EB} = -5V, I_C = 0$	-0.078	—	-0.145	
	RN2306		—		-0.074	—	-0.138	
DC current gain	RN2301	h_{FE}	—	$V_{CE} = -5V$ $I_C = -10mA$	30	—	—	—
	RN2302		—		50	—	—	
	RN2303		—		70	—	—	
	RN2304		—		80	—	—	
	RN2305		—		80	—	—	
	RN2306		—		80	—	—	
Collector-emitter saturation voltage	RN2301~2306	$V_{CE(sat)}$	—	$I_C = -5mA$ $I_B = -0.25mA$	—	-0.1	-0.3	V
Input voltage (ON)	RN2301	$V_{I(ON)}$	—	$V_{CE} = -0.2V$ $I_C = -5mA$	-1.1	—	-2.0	V
	RN2302		—		-1.2	—	-2.4	
	RN2303		—		-1.3	—	-3.0	
	RN2304		—		-1.5	—	-5.0	
	RN2305		—		-0.6	—	-1.1	
	RN2306		—		-0.7	—	-1.3	
Input voltage (OFF)	RN2301~2304	$V_{I(OFF)}$	—	$V_{CE} = -5V,$ $I_C = -0.1mA$	-1.0	—	-1.5	V
	RN2305, 2306		—		-0.5	—	-0.8	
Translation frequency	RN2301~2306	f_T	—	$V_{CE} = -10V,$ $I_C = -5mA$	—	200	—	MHz
Collector output capacitance	RN2301~2306	C_{ob}	—	$V_{CB} = -10V, I_E = 0$ $f = 1MHz$	—	3	6	pF
Input resistor	RN2301	R1	—	—	3.29	4.7	6.11	kΩ
	RN2302		—		7	10	13	
	RN2303		—		15.4	22	28.6	
	RN2304		—		32.9	47	61.1	
	RN2305		—		1.54	2.2	2.86	
	RN2306		—		3.29	4.7	6.11	
Resistor ratio	RN2301~2304	R1/R2	—	—	0.9	1.0	1.1	—
	RN2305		—		0.0421	0.0468	0.0515	
	RN2306		—		0.09	0.1	0.11	

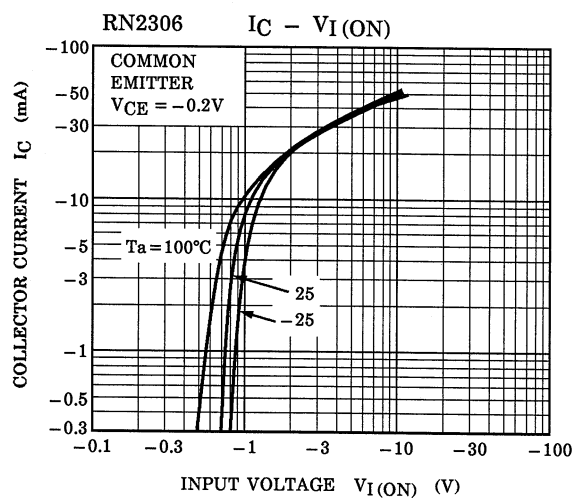
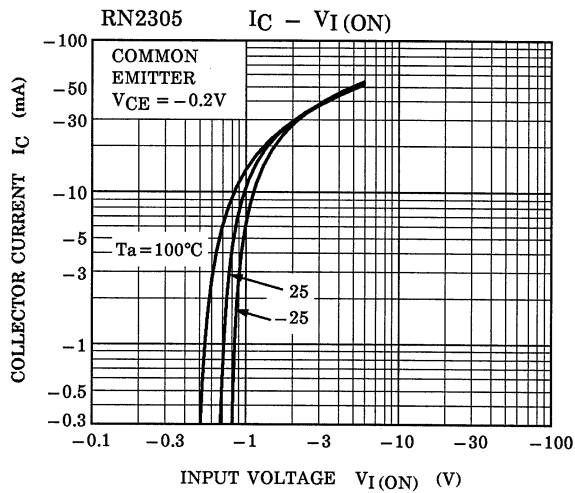
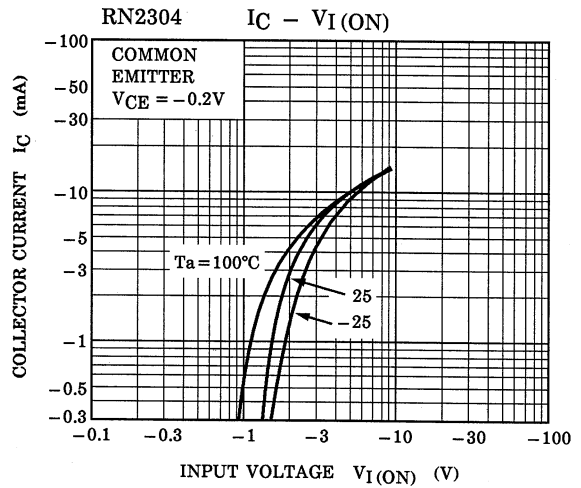
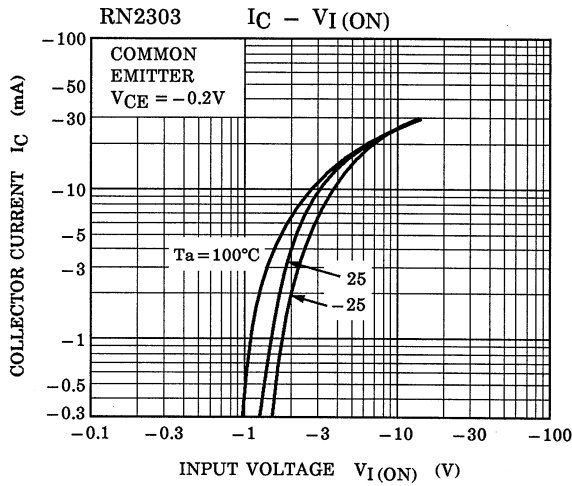
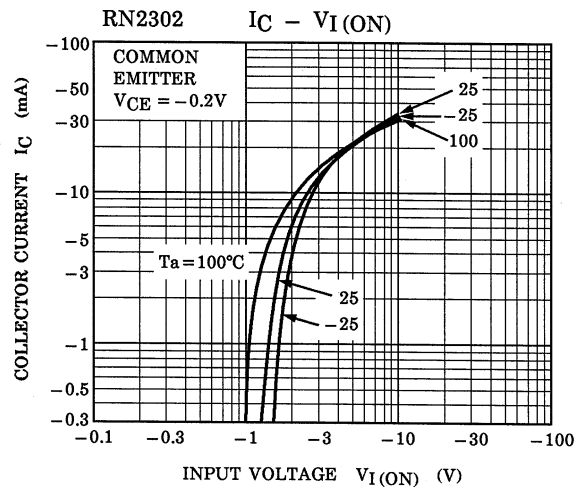
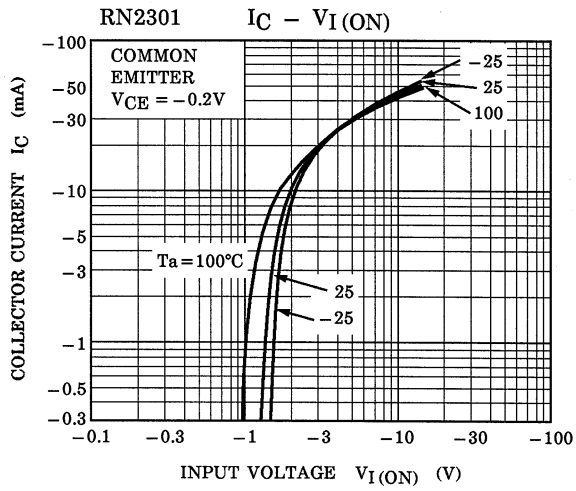

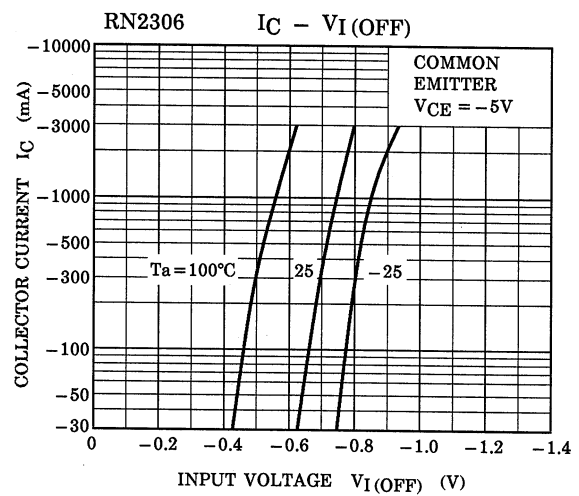
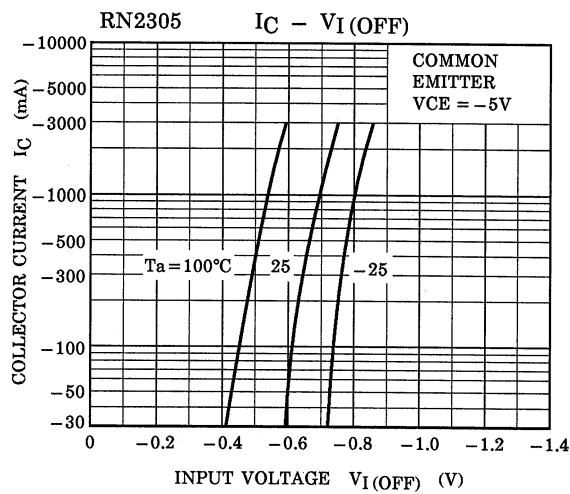
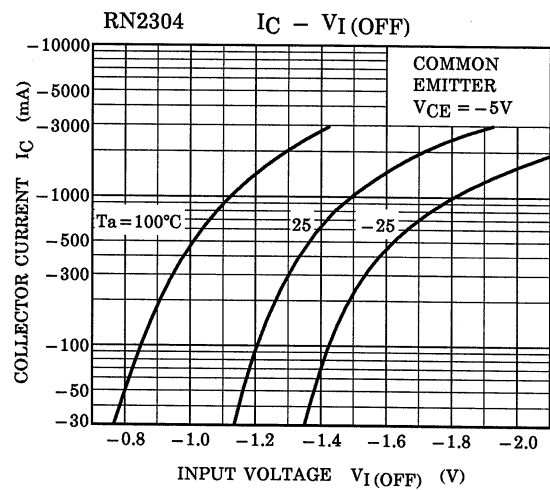
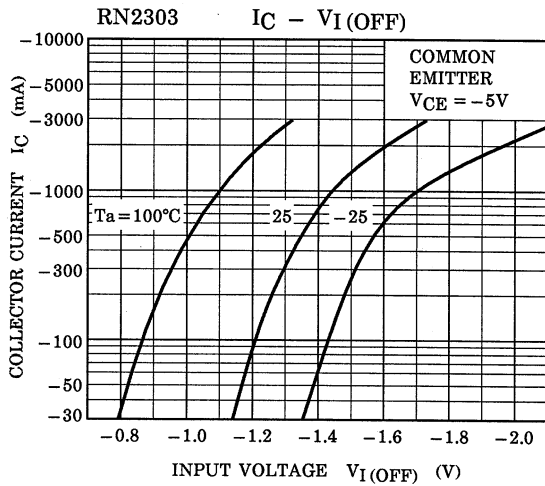
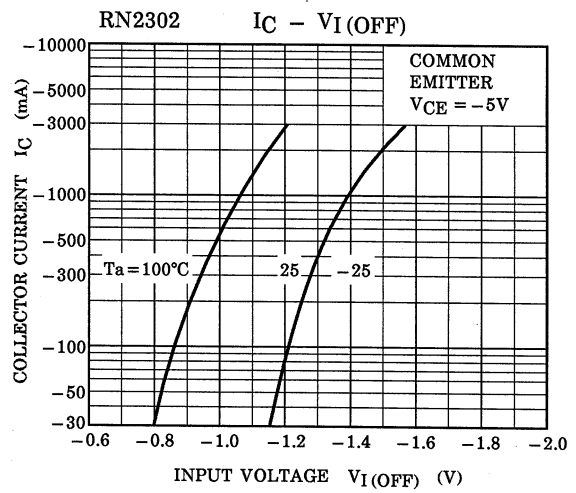
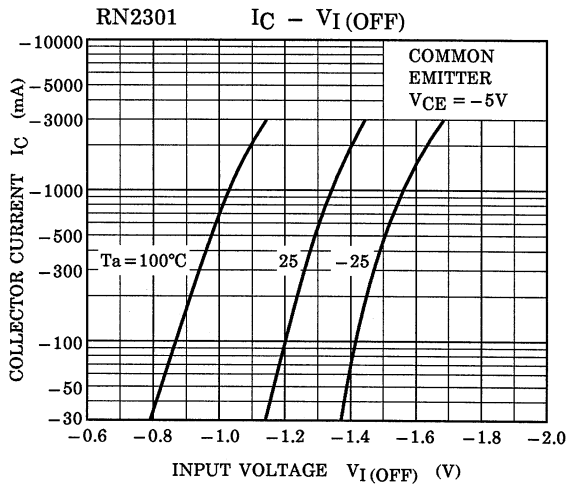

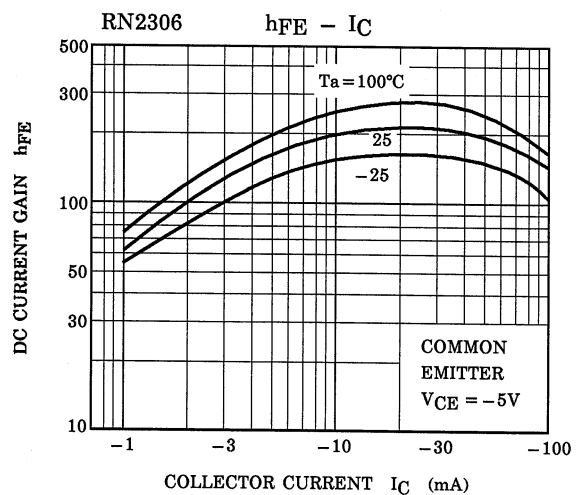
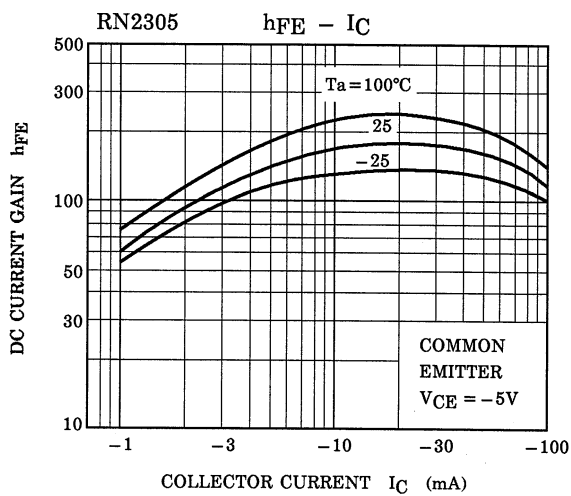
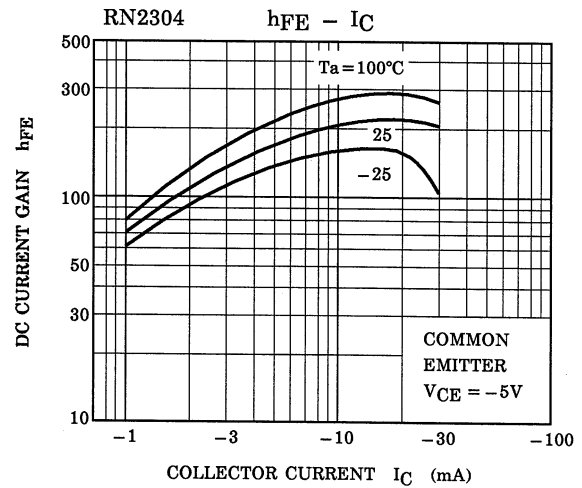
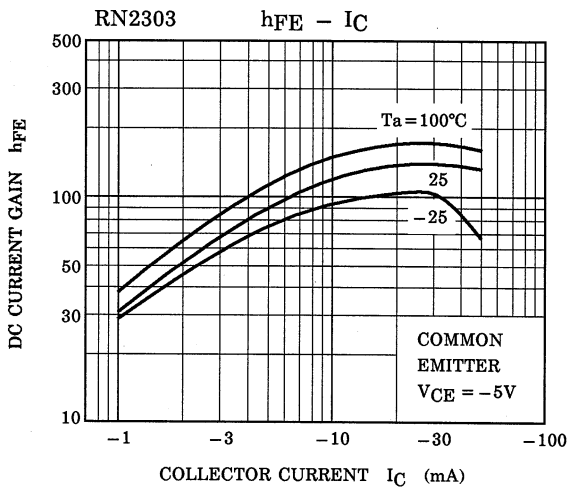
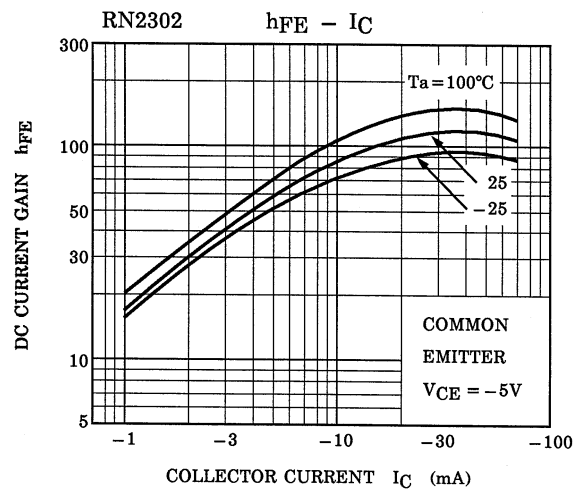
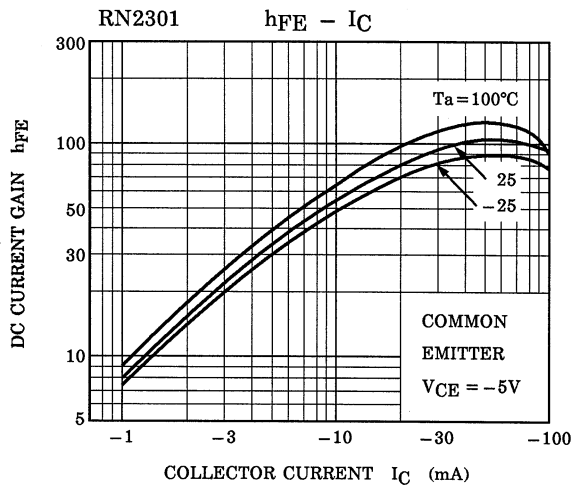

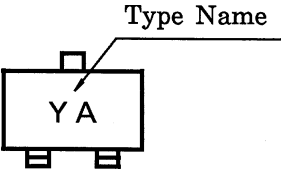
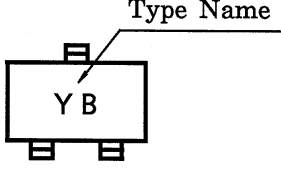
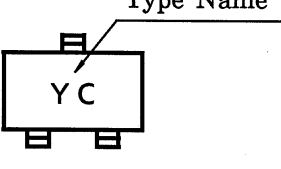
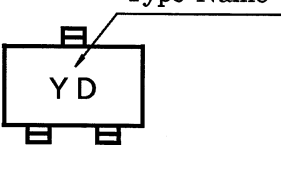
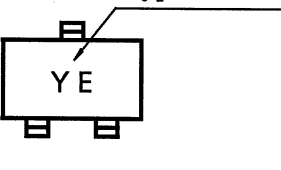
Type Name	Marking
RN2301	
RN2302	
RN2303	
RN2304	
RN2305	
RN2306	