

TOSHIBA Transistor Silicon PNP Epitaxial Type (PCT Process)

RN2501,RN2502,RN2503 RN2504,RN2505,RN2506

Switching, Inverter Circuit, Interface Circuit
And Driver Circuit Applications

Unit in mm

- Including two devices in SMV (super mini type with 5 leads)
- With built-in bias resistors
- Simplify circuit design
- Reduce a quantity of parts and manufacturing process
- Complementary to RN1501~RN1506

Equivalent Circuit and Bias Resistor Values

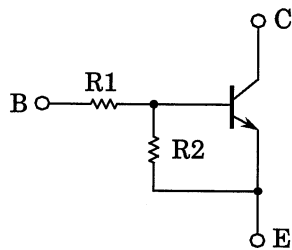

Type No.	R1 (kΩ)	R2 (kΩ)
RN2501	4.7	4.7
RN2502	10	10
RN2503	22	22
RN2504	47	47
RN2505	2.2	47
RN2506	4.7	47

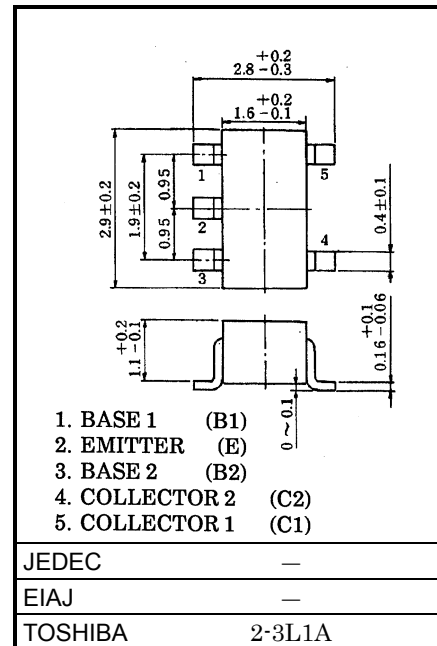

JEDEC	—
EIAJ	—
TOSHIBA	2-3L1A

Weight: 0.014g

Equivalent Circuit (Top View)

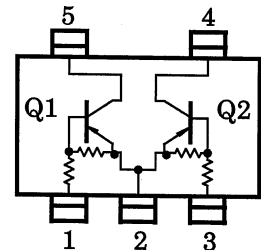

Maximum Ratings (Ta = 25°C) (Q1, Q2 Common)

Characteristic	Symbol	Rating	Unit
Collector-base voltage	V _{CB0}	-50	V
Collector-emitter voltage			
Emitter base voltage	V _{EB0}	-10	V
		-5	
Collector current	I _C	-100	mA
Collector power dissipation	P _C *	300	mW
Junction temperature	T _j	150	°C
Storage temperature range	T _{stg}	-55~150	°C

* Total rating

961001EAA2

- TOSHIBA is continually working to improve the quality and the reliability of its products. Nevertheless, semiconductor devices in general can malfunction or fail due to their inherent electrical sensitivity and vulnerability to physical stress. It is the responsibility of the buyer, when utilizing TOSHIBA products, to observe standards of safety, and to avoid situations in which a malfunction or failure of a TOSHIBA product could cause loss of human life, bodily injury or damage to property. In developing your designs, please ensure that TOSHIBA products are used within specified operating ranges as set forth in the most recent products specifications. Also, please keep in mind the precautions and conditions set forth in the TOSHIBA Semiconductor Reliability Handbook.
- The information contained herein is presented only as a guide for the applications of our products. No responsibility is assumed by TOSHIBA CORPORATION for any infringements of intellectual property or other rights of the third parties which may result from its use. No license is granted by implication or otherwise under any intellectual property or other rights of TOSHIBA CORPORATION or others.
- The information contained herein is subject to change without notice.

Electrical Characteristics (Ta = 25°C) (Q1, Q2 Common)

Characteristic		Symbol	Test Circuit	Test Condition	Min	Typ.	Max	Unit
Collector cut-off current	RN2501~2506	I_{CBO}	—	$V_{CB} = -50V, I_E = 0$	—	—	-100	nA
		I_{CEO}	—	$V_{CE} = -50V, I_B = 0$	—	—	-500	
Emitter cut-off current	RN2501	I_{EBO}	—	$V_{EB} = -10V, I_C = 0$	-0.82	—	-1.52	mA
	RN2502		—		-0.38	—	-0.71	
	RN2503		—		-0.17	—	-0.33	
	RN2504		—	-0.082	—	-0.15		
	RN2505		—	$V_{EB} = -5V, I_C = 0$	-0.078	—	-0.145	
	RN2506		—		-0.074	—	-0.138	
DC current gain	RN2501	h_{FE}	—	$V_{CE} = -5V$ $I_C = -10mA$	30	—	—	—
	RN2502		—		50	—	—	
	RN2503		—		70	—	—	
	RN2504		—		80	—	—	
	RN2505		—		80	—	—	
	RN2506		—		80	—	—	
Collector-emitter saturation voltage	RN2501~2506	$V_{CE(sat)}$	—	$I_C = -5mA$ $I_B = -0.25mA$	—	-0.1	-0.3	V
Input voltage (ON)	RN2501	$V_{I(ON)}$	—	$V_{CE} = -0.2V$ $I_C = -5mA$	-1.1	—	-2.0	V
	RN2502		—		-1.2	—	-2.4	
	RN2503		—		-1.3	—	-3.0	
	RN2504		—		-1.5	—	-5.0	
	RN2505		—		-0.6	—	-1.1	
	RN2506		—		-0.7	—	-1.3	
Input voltage (OFF)	RN2501~2504	$V_{I(OFF)}$	—	$V_{CE} = -5V$ $I_C = -0.1mA$	-1.0	—	-1.5	V
	RN2505, 2506		—		-0.5	—	-0.8	
Translation frequency	RN2501~2506	f_T	—	$V_{CE} = -10V$ $I_C = -5mA$	—	200	—	MHz
Collector output capacitance	RN2501~2506	C_{ob}	—	$V_{CB} = -10V, I_E = 0$ $f = 1MHz$	—	3	6	pF
Input resistor	RN2501	R1	—	—	3.29	4.7	6.11	kΩ
	RN2502		—		7	10	13	
	RN2503		—		15.4	22	28.6	
	RN2504		—		32.9	47	61.1	
	RN2505		—		1.54	2.2	2.86	
	RN2506		—		3.29	4.7	6.11	
Resistor ratio	RN2501~2504	R1/R2	—	—	0.9	1.0	1.1	—
	RN2505		—		0.0421	0.0468	0.0515	
	RN2506		—		0.09	0.1	0.11	

(Q1, Q2 Common)

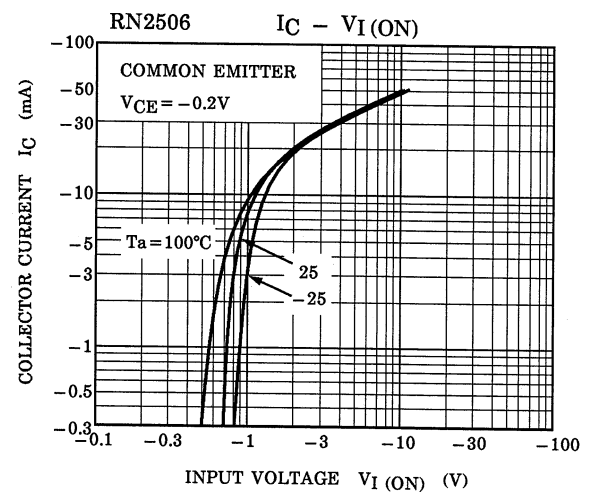
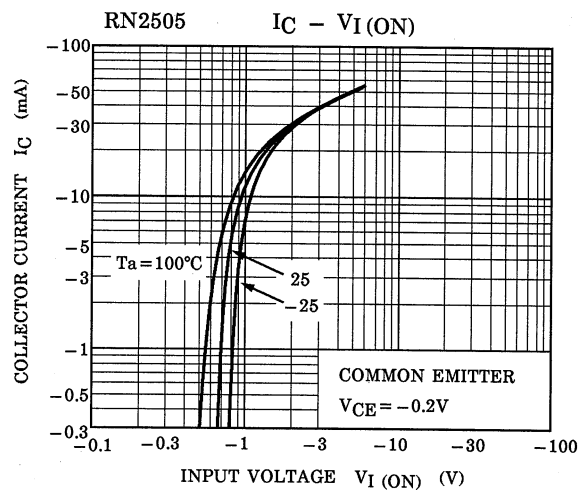
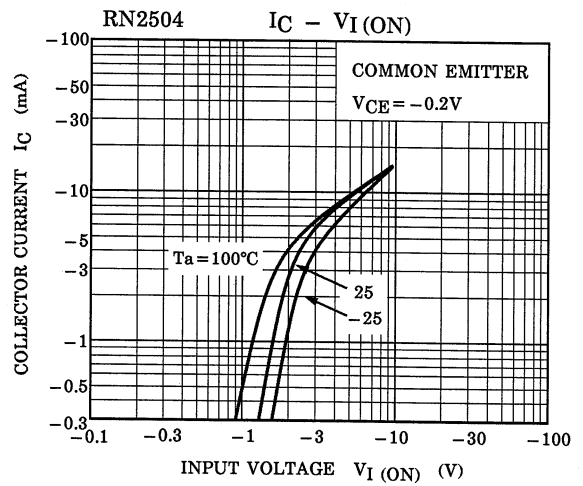
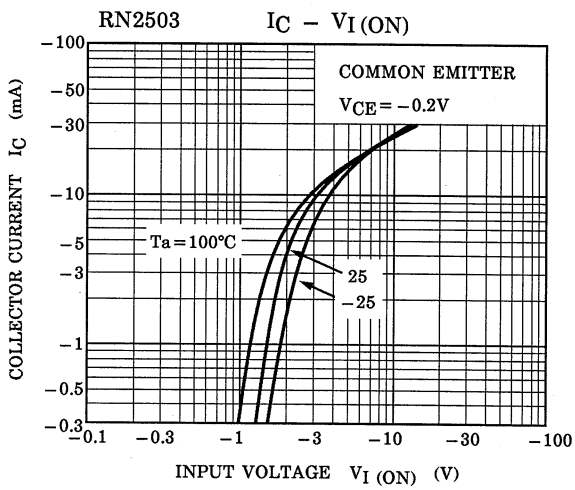
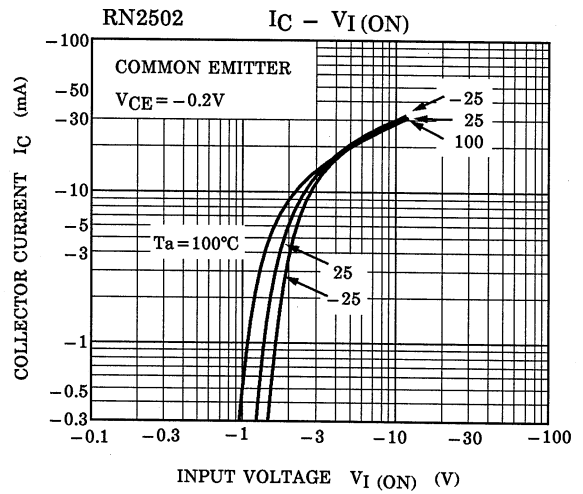
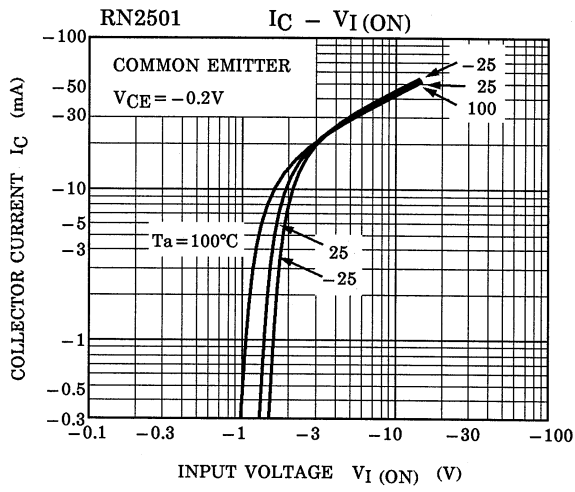

(Q1, Q2 Common)

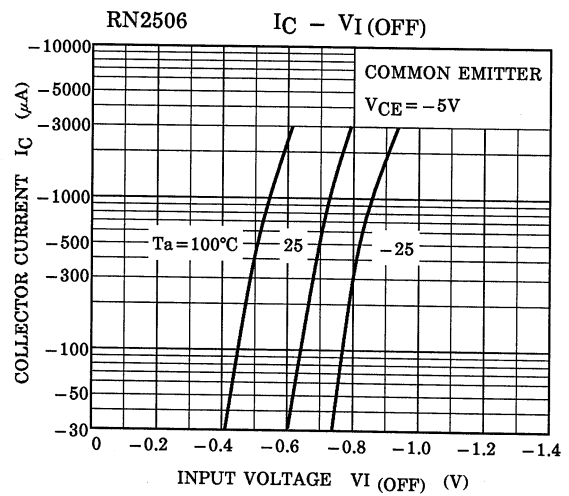
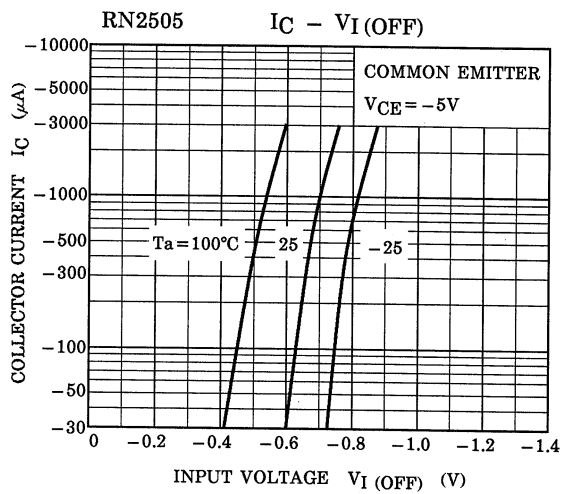
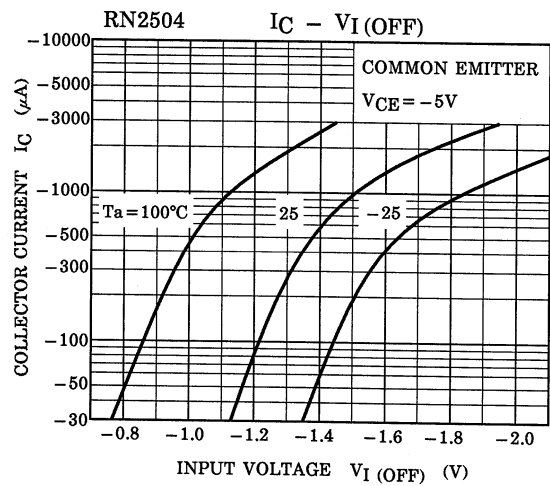
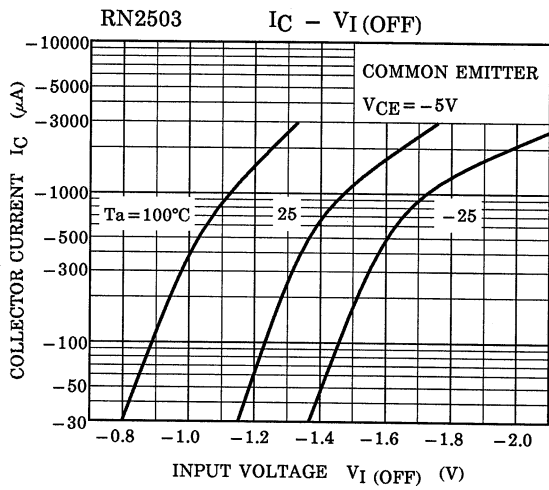
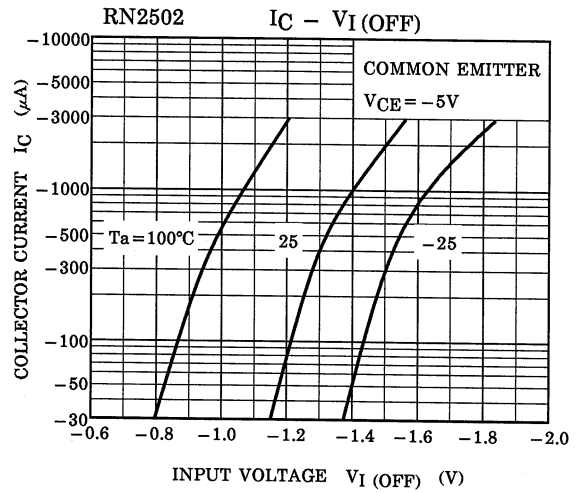
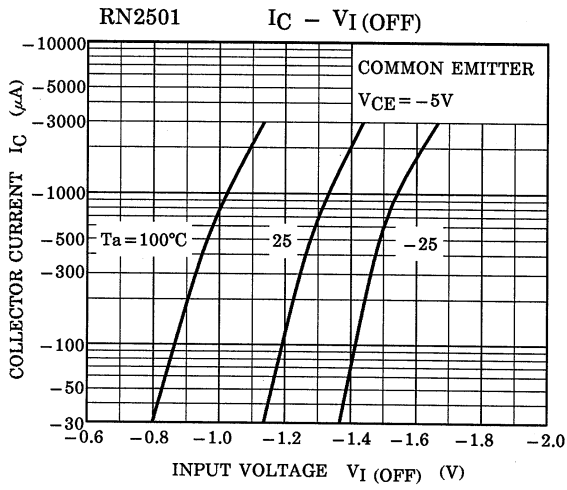

(Q1, Q2 Common)

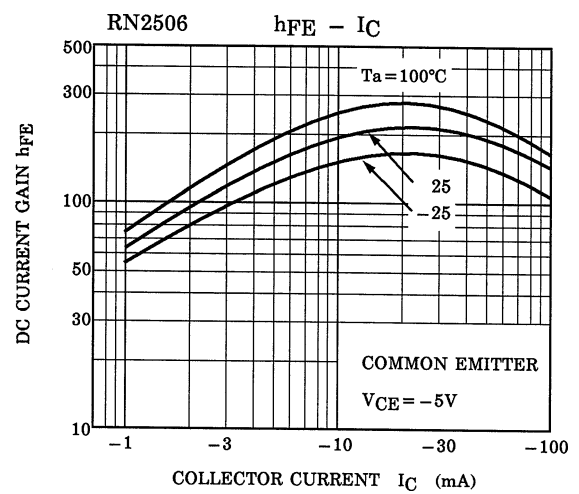
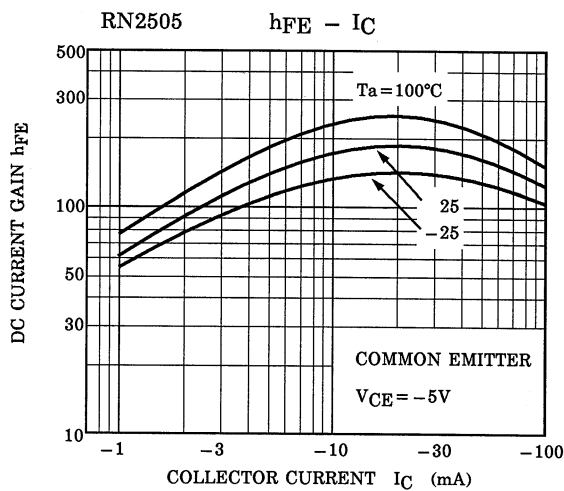
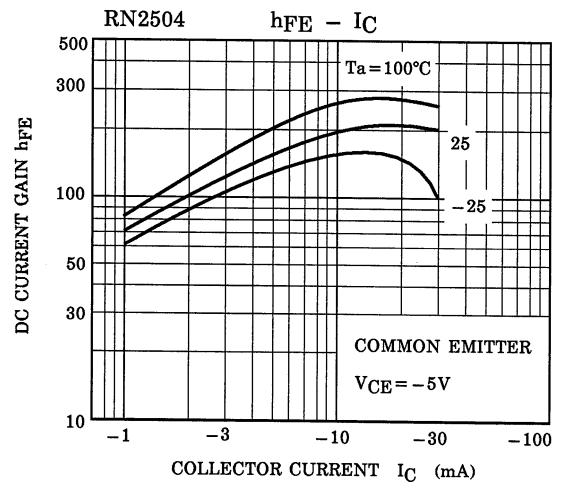
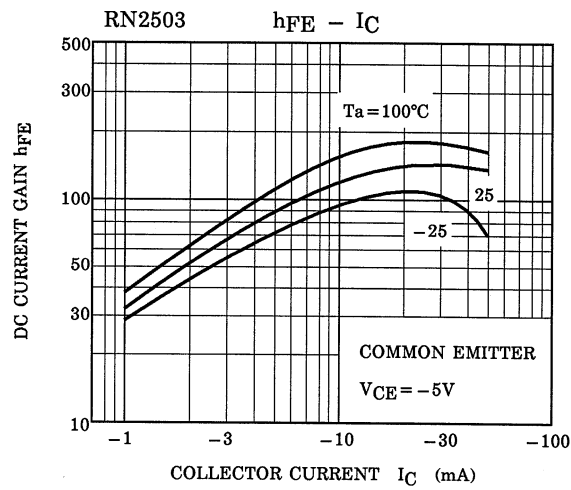
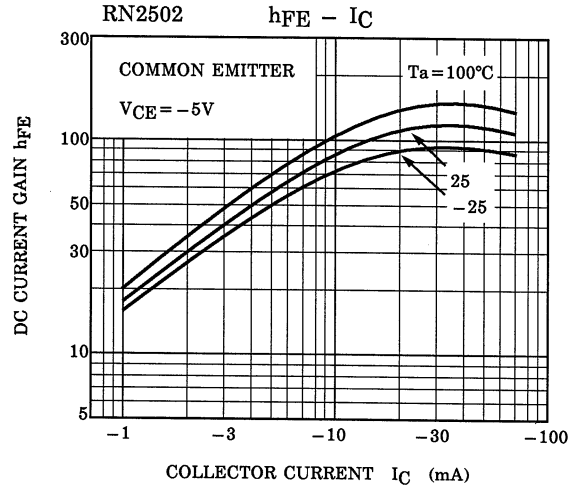
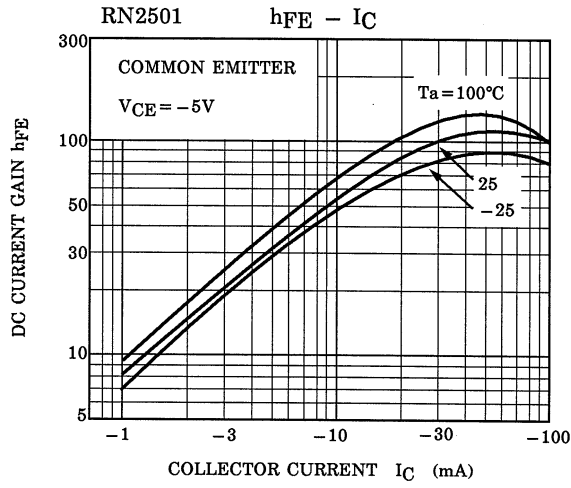

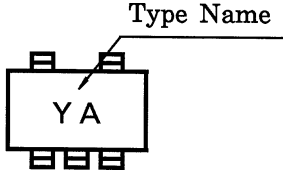
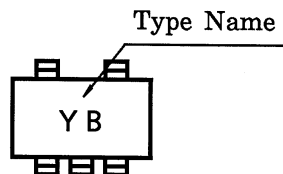
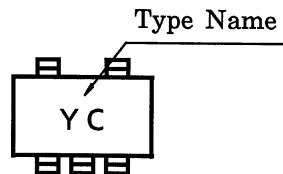
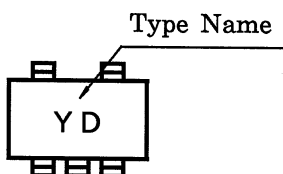
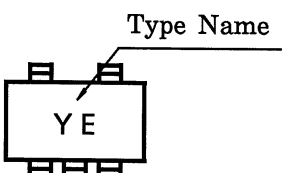
Type Name	Marking
RN2501	
RN2502	
RN2503	
RN2504	
RN2505	
RN2506	