

# SHINDENGEN

## General Purpose Rectifiers

DIL Bridges

# S10WB20

## 200V 10A

### OUTLINE DIMENSIONS

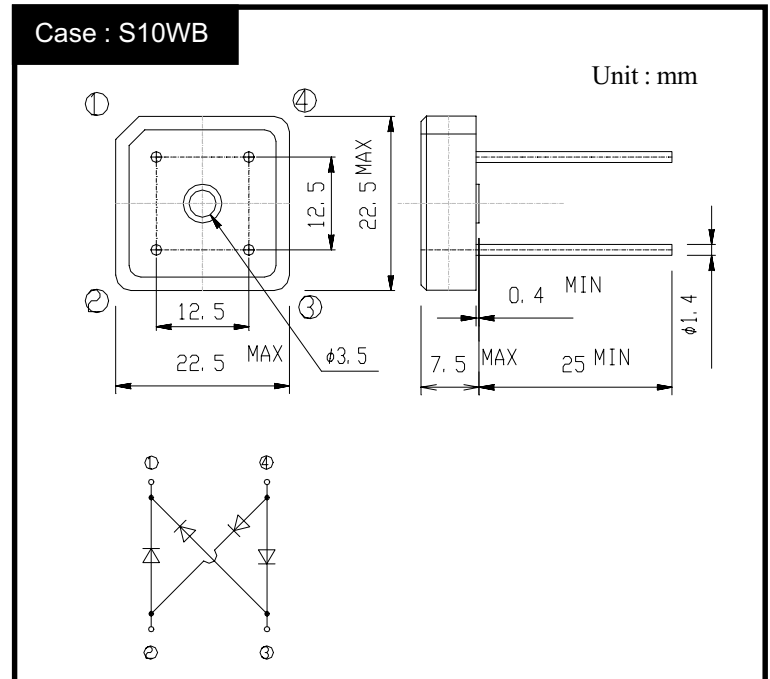

### RATINGS

#### ● Absolute Maximum Ratings

Item	Symbol	Conditions	Ratings	Unit
Storage Temperature	$T_{stg}$		-40~150	°C
Operating Junction Temperature	$T_j$		150	°C
Maximum Reverse Voltage	$V_{RM}$		200	V
Average Rectified Forward Current	$I_O$	50Hz sine wave, R-load With heatsink $T_c=74^\circ\text{C}$	10	A
		50Hz sine wave, R-load Without heatsink $T_a=25^\circ\text{C}$	3.2	
Peak Surge Forward Current	$I_{FSM}$	50Hz sine wave, Non-repetitive 1cycle peak value, $T_j=25^\circ\text{C}$	170	A
Current Squared Time	$I^2t$	$1\text{ms} \leq t < 10\text{ms}$ $T_j=25^\circ\text{C}$	110	$\text{A}^2\text{s}$
Dielectric Strength	$V_{dis}$	Terminals to case, AC 1 minute	2	kV
Mounting Torque	TOR	(Recommended torque : 0.5N·m)	0.8	N·m

#### ● Electrical Characteristics ( $T_c=25^\circ\text{C}$ )

Item	Symbol	Conditions	Ratings	Unit
Forward Voltage	$V_F$	$I_F=5\text{A}$ , Pulse measurement, Rating of per diode	Max.1.05	V
Reverse Current	$I_R$	$V_R=V_{RM}$ , Pulse measurement, Rating of per diode	Max.10	$\mu\text{A}$
Thermal Resistance	$\theta_{jc}$	junction to case, With heatsink	Max.3.9	°C/W
	$\theta_{jl}$	junction to lead, Without heatsink	Max.4	
	$\theta_{ja}$	junction to ambient, Without heatsink	Max.24	

S10WBx

Forward Voltage

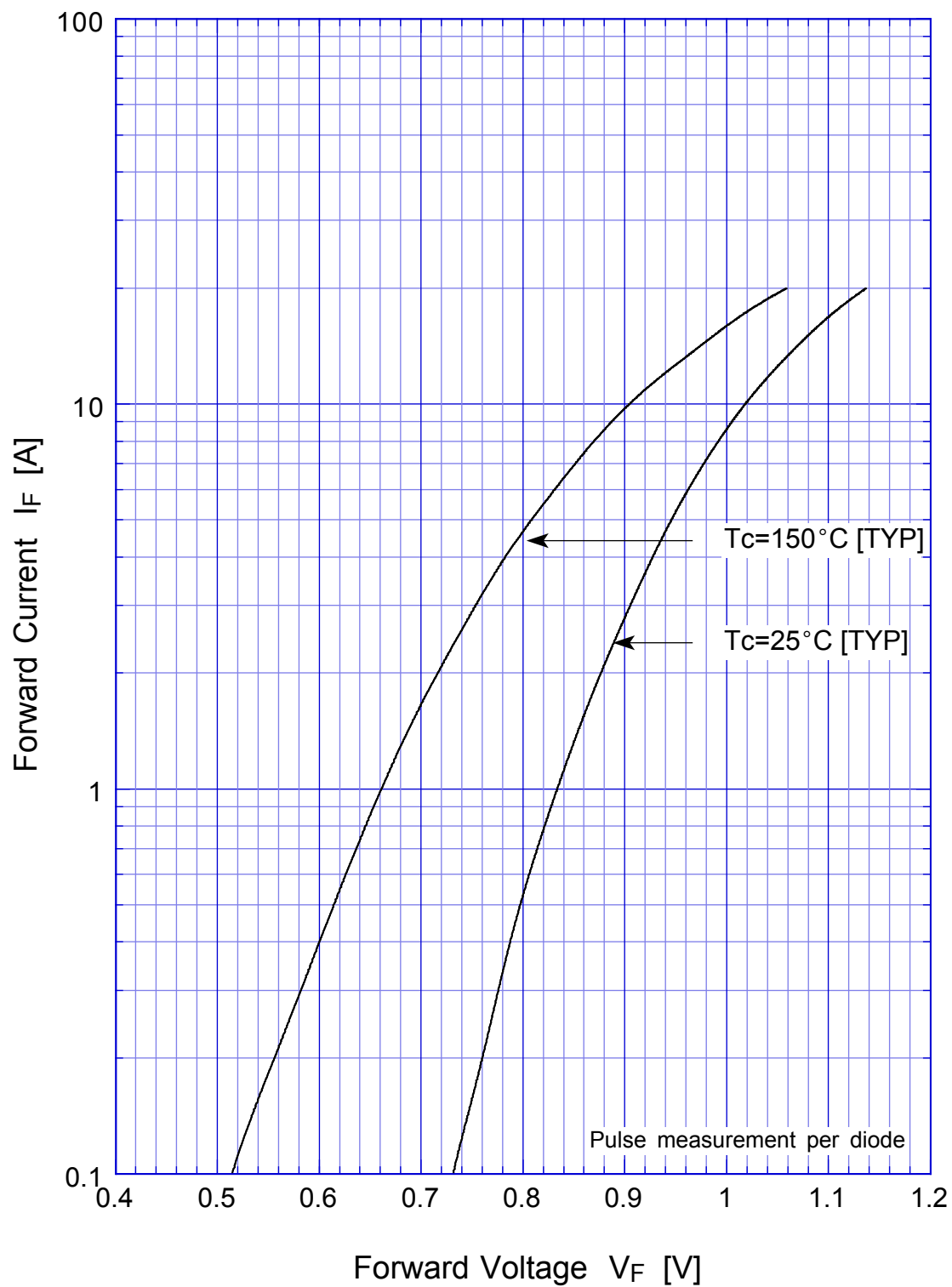

## S10WBx Forward Power Dissipation

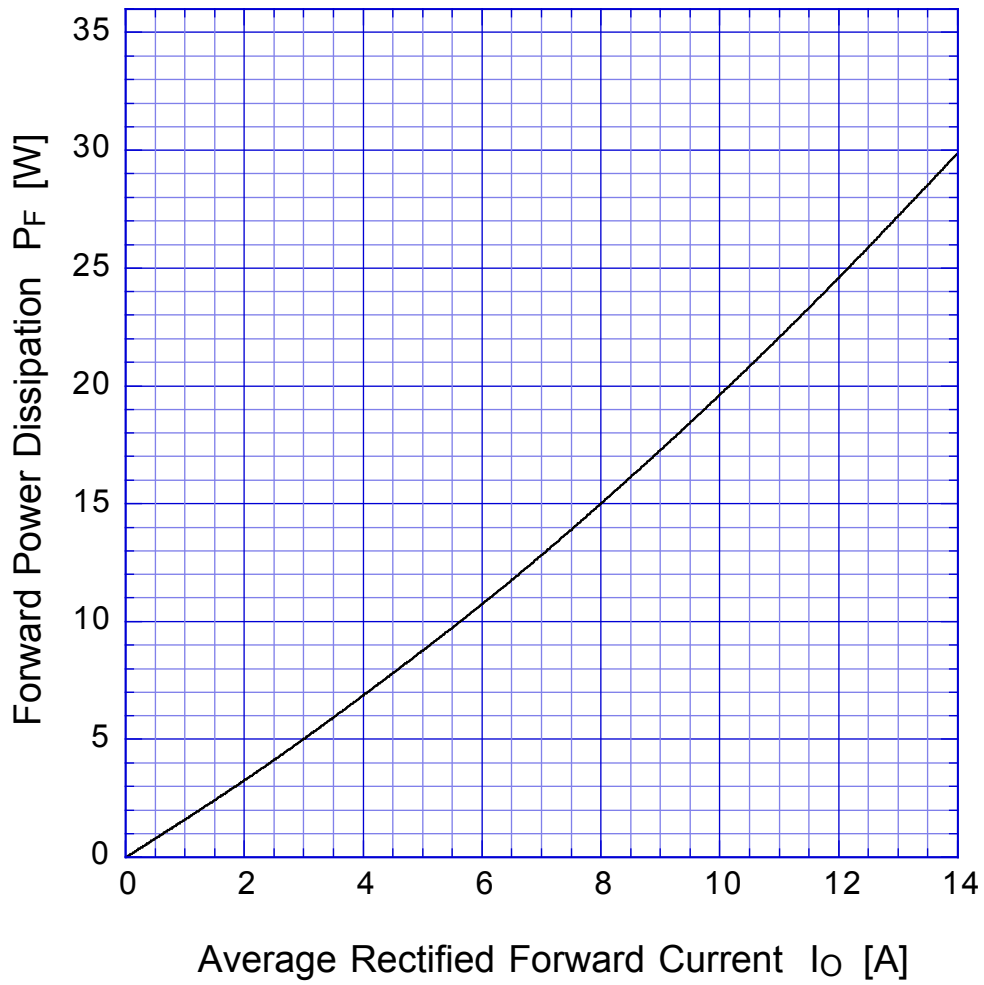

$T_j = 150^\circ\text{C}$   
Sine wave

# S10WBx

## Peak Surge Forward Capability

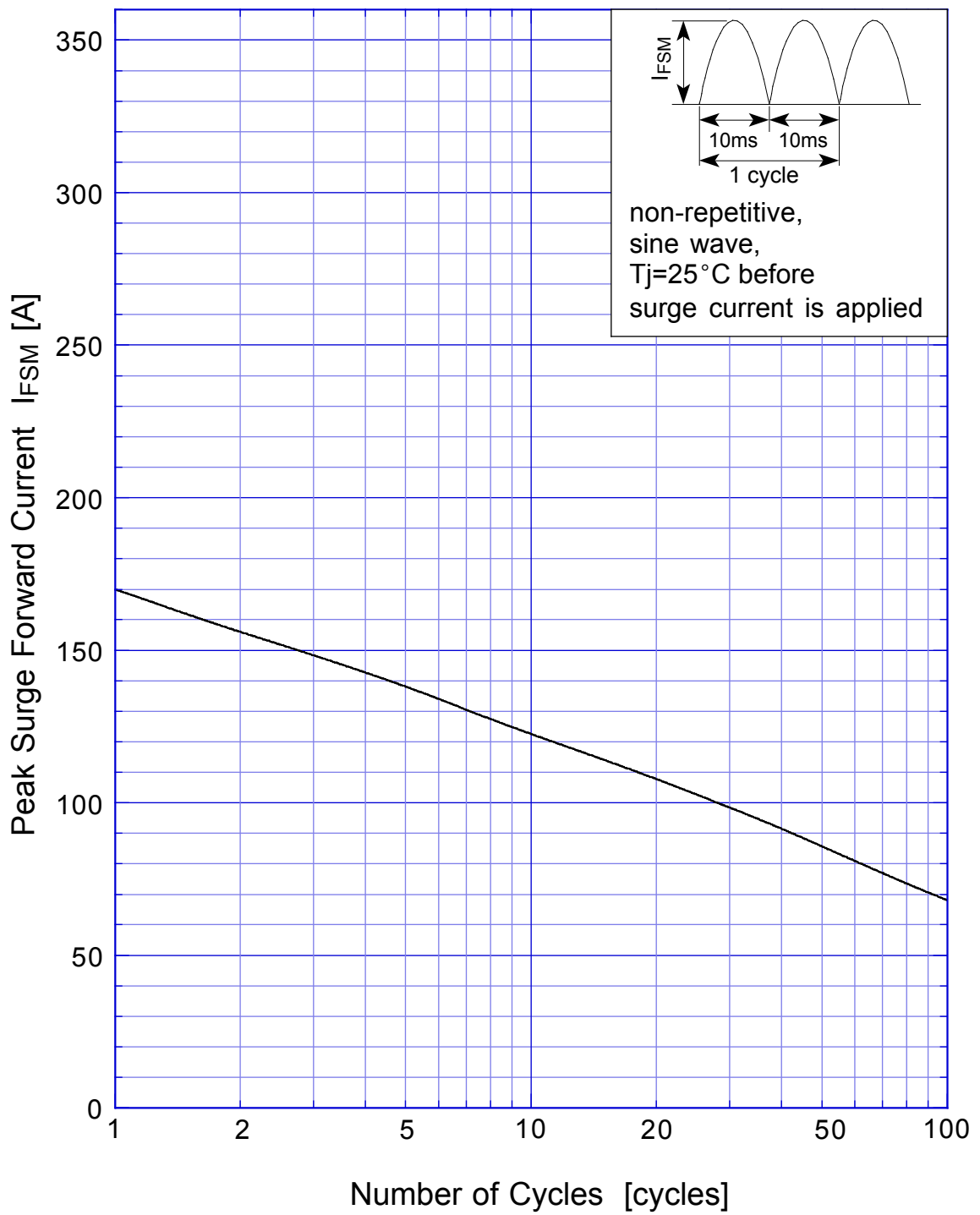

# S10WBx

# Derating Curve

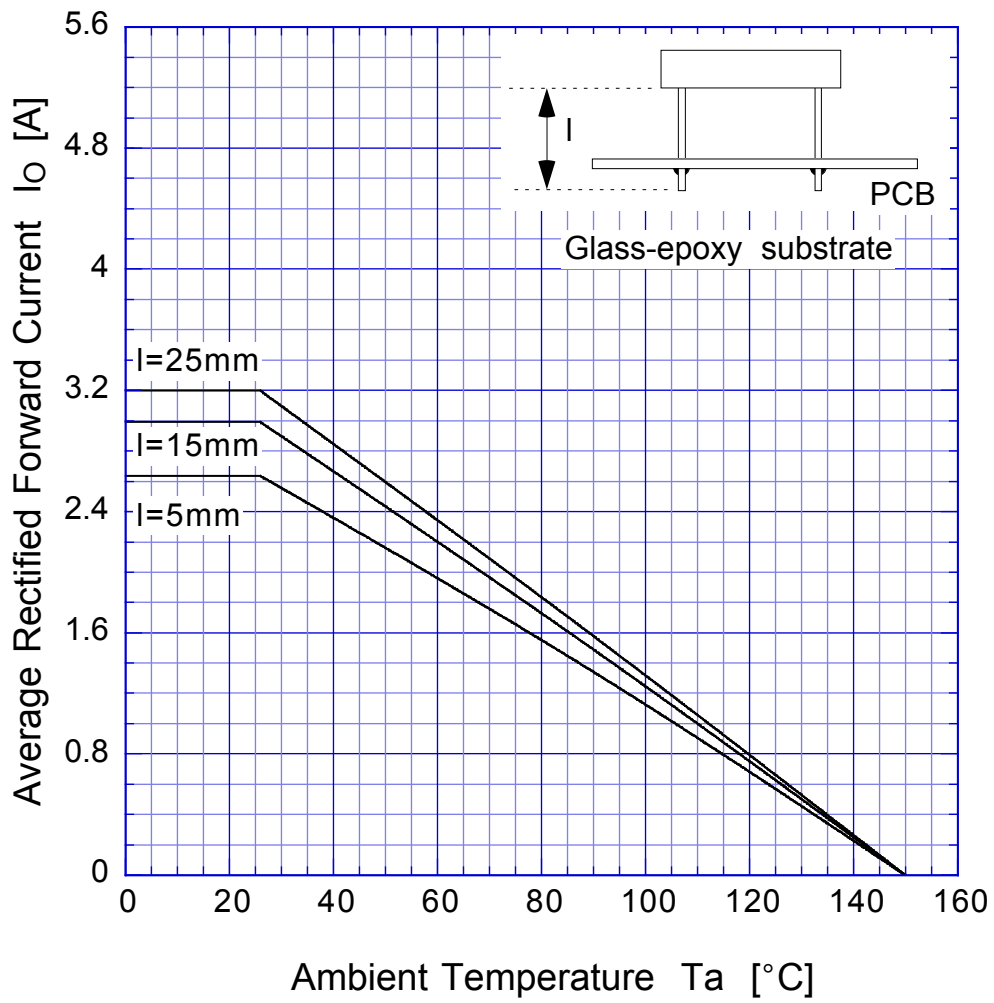

Sine wave  
R-load  
Free in air  
no heatsink

# S10WBx

## Derating Curve

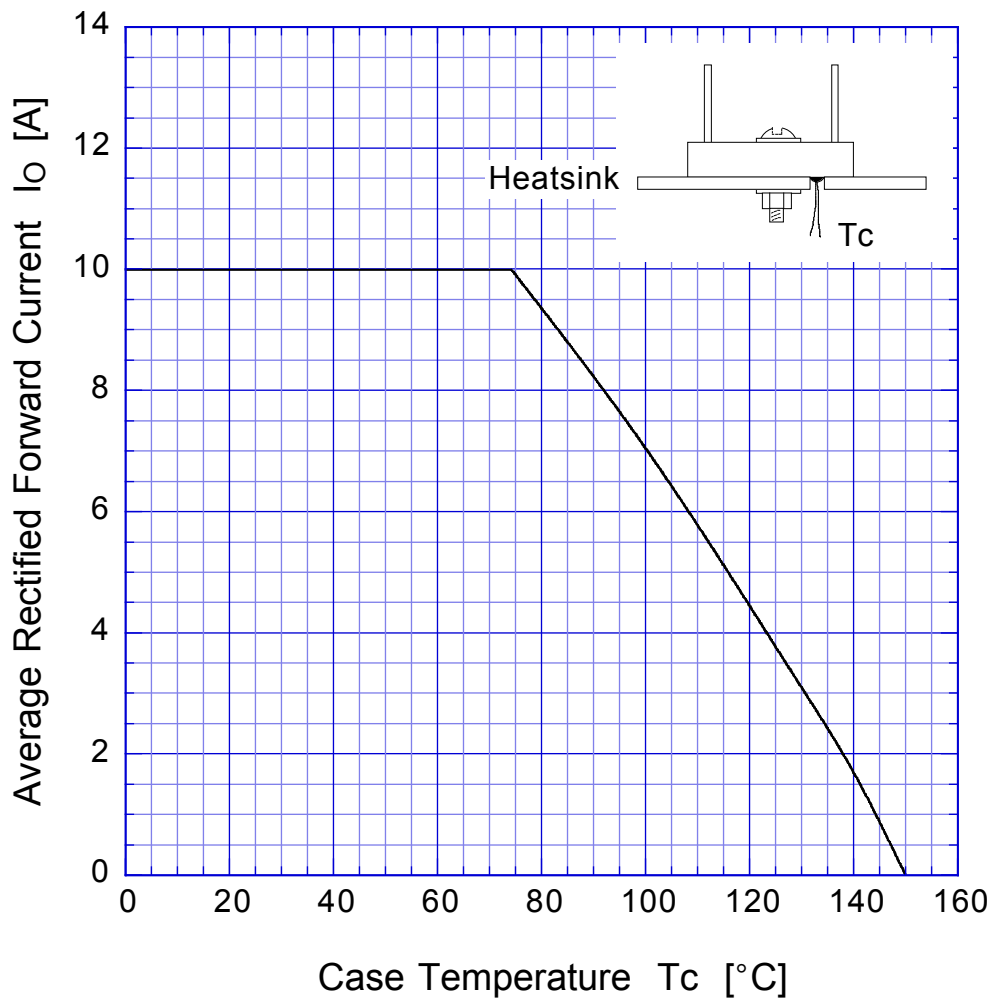

Sine wave  
R-load