

# SHINDENGEN

## General Purpose Rectifiers

Single

# S2V60

## 600V 1.7A

### FEATURES

- High voltage
- High reliability with superior moisture resistance
- Applicable to Automatic Insertion

### APPLICATION

- Conventional Rectification
- Power source(Power Supply)
- Home Appliances, Office Equipment
- Telecommunication, Factory Automation

## OUTLINE DIMENSIONS

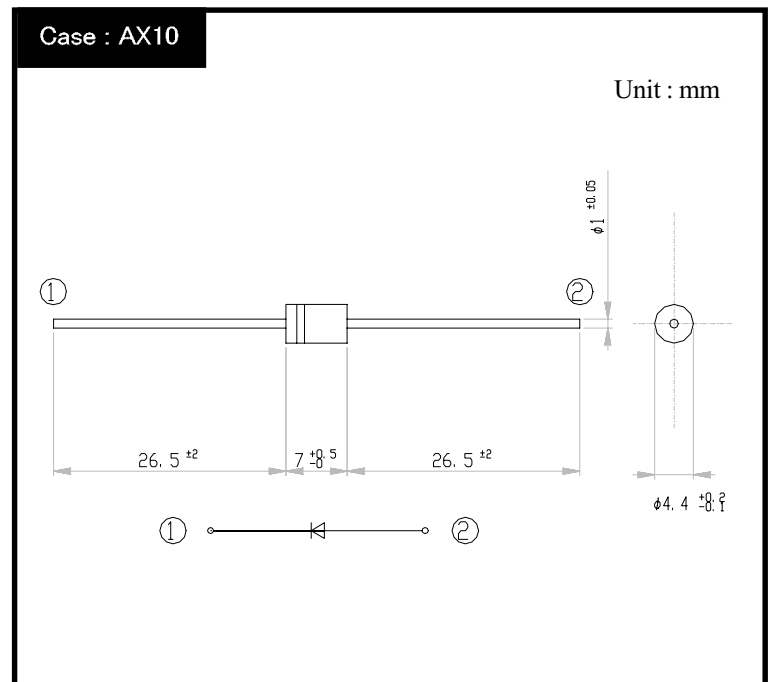

## RATINGS

### ● Absolute Maximum Ratings (If not specified Tl=25°C)

Item	Symbol	Conditions	Ratings	Unit
Storage Temperature	T <sub>stg</sub>		-55 ~ 150	°C
Operating Junction Temperature	T <sub>j</sub>		150	°C
Maximum Reverse Voltage	V <sub>RM</sub>		600	V
Average Rectified Forward Current	I <sub>O</sub>	50Hz sine wave, R-load, T <sub>a</sub> =40°C	1.7	A
Peak Surge Forward Current	I <sub>FSM</sub>	50Hz sine wave, Non-repetitive 1cycle peak value, T <sub>j</sub> =25°C	60	A
Current Squared Time	I <sup>2</sup> t	1ms ≤ t < 10ms T <sub>j</sub> =25°C	20	A <sup>2</sup> s

### ● Electrical Characteristics (If not specified Tl=25°C)

Item	Symbol	Conditions	Ratings	Unit
Forward Voltage	V <sub>F</sub>	I <sub>F</sub> =1.7A, Pulse measurement	Max.1.05	V
Reverse Current	I <sub>R</sub>	V <sub>R</sub> =V <sub>RM</sub> , Pulse measurement	Max.10	μA
Thermal Resistance	θ <sub>j-l</sub>	junction to lead	Max.8	°C/W

S2Vx

Forward Voltage

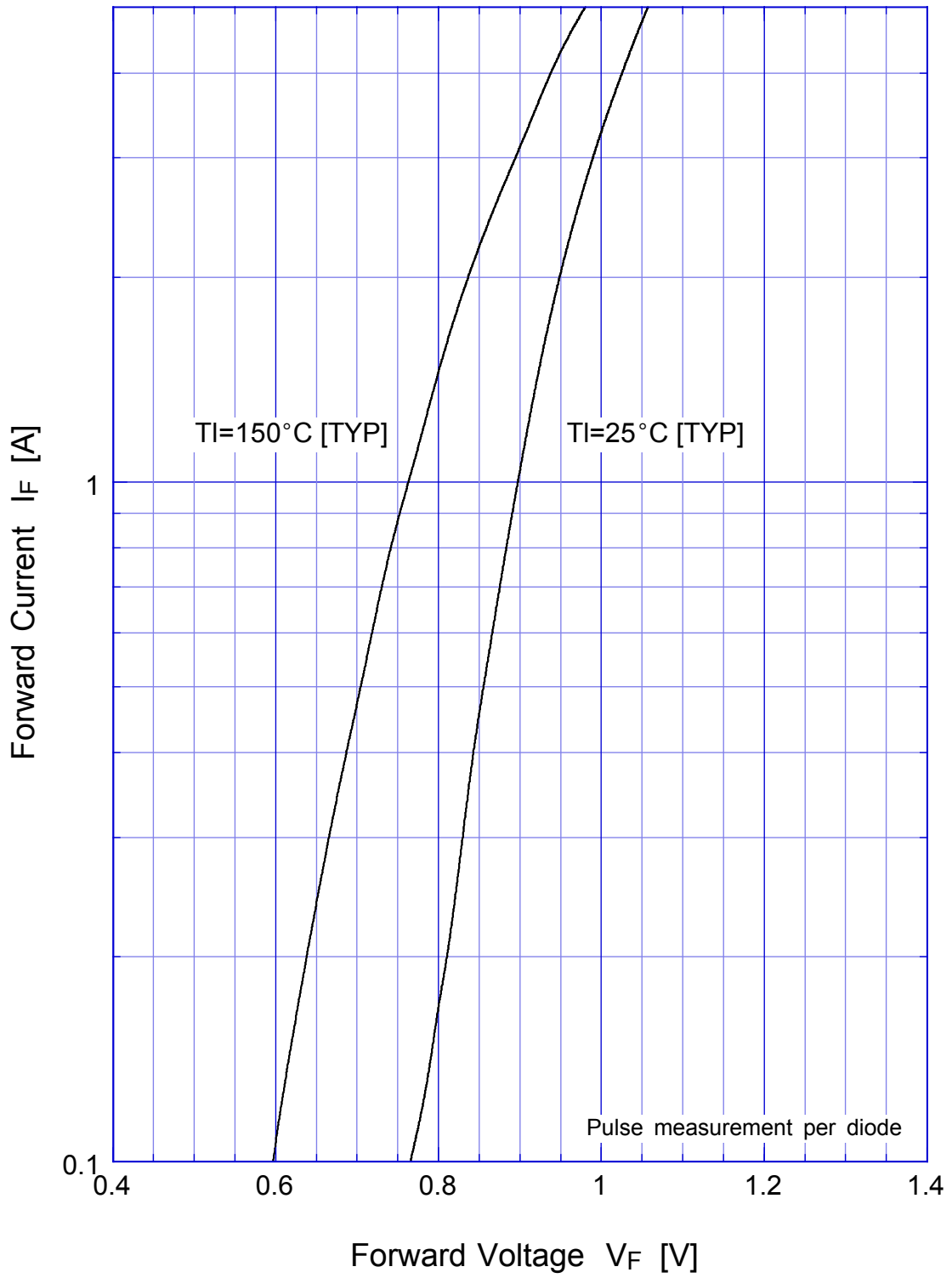

S2Vx

Forward Power Dissipation

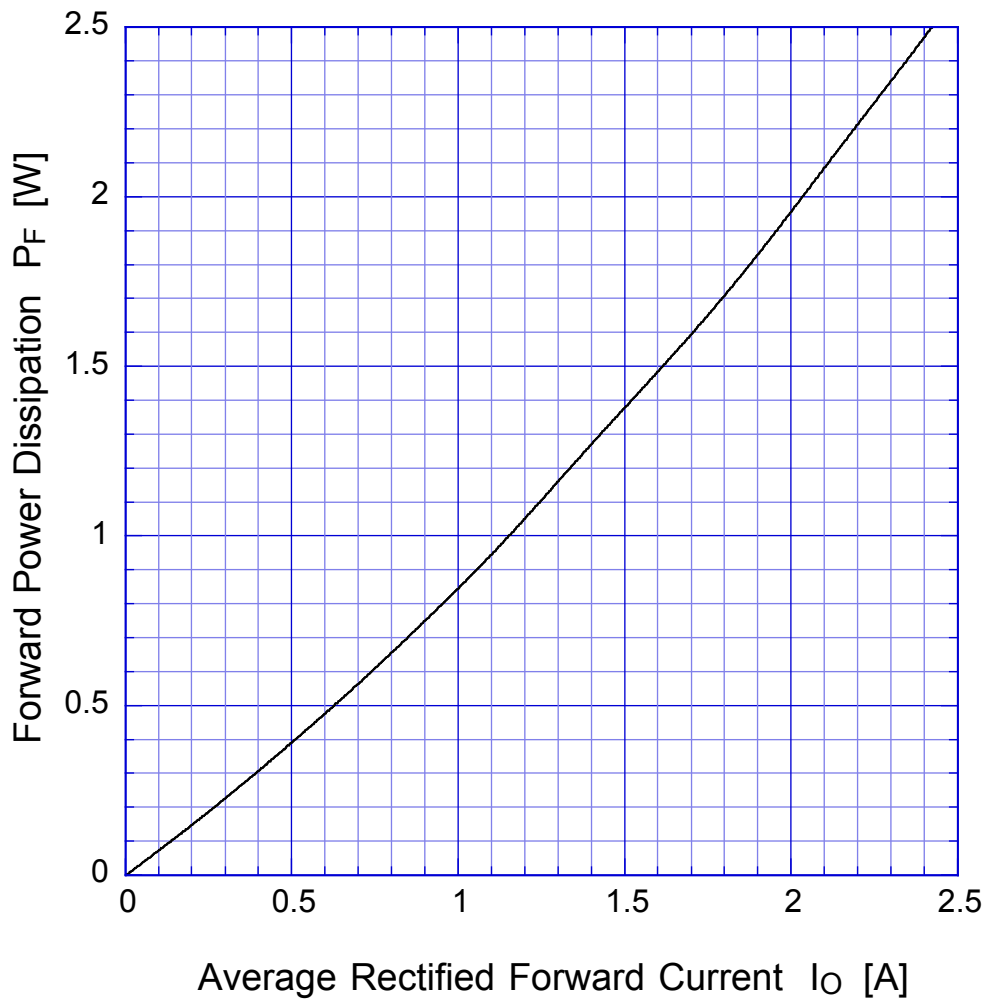

$T_j = 150^\circ\text{C}$   
Sine wave

S2Vx

Derating Curve

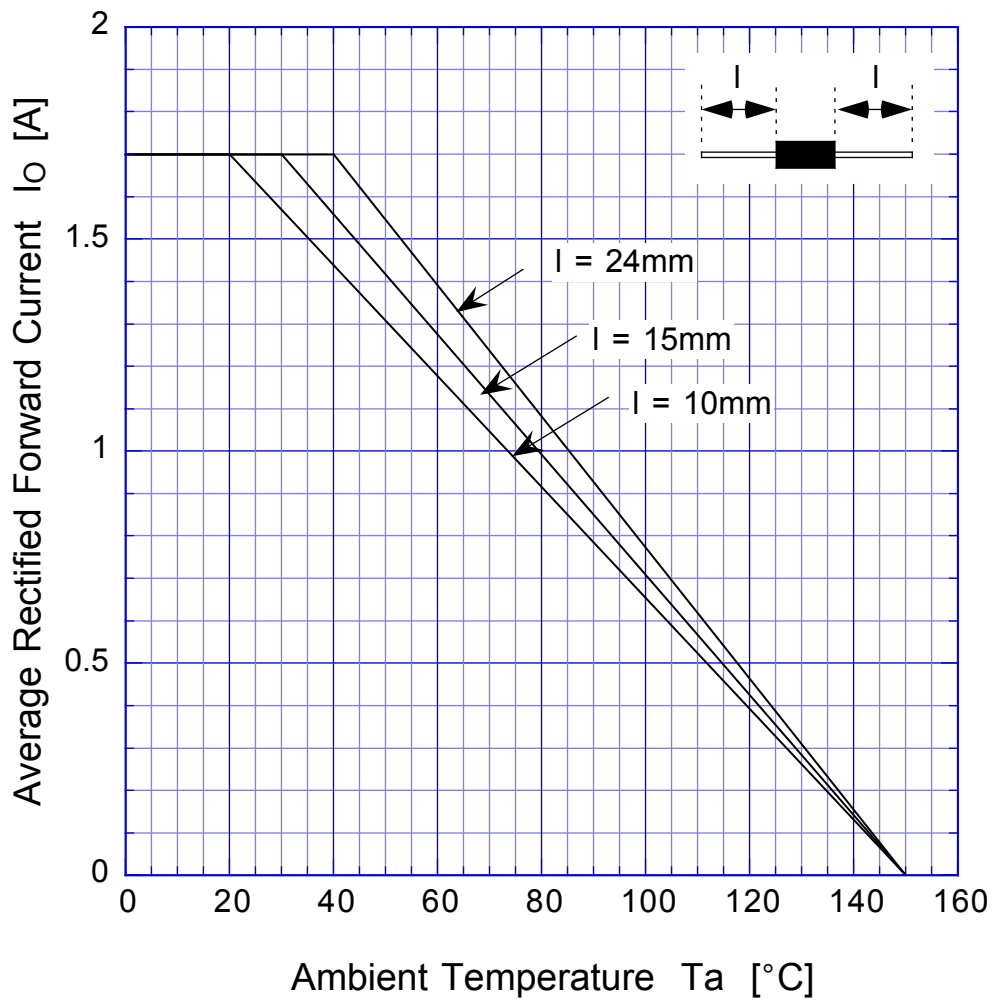

Sine wave  
R-load  
Free in air

S2Vx

Peak Surge Forward Capability

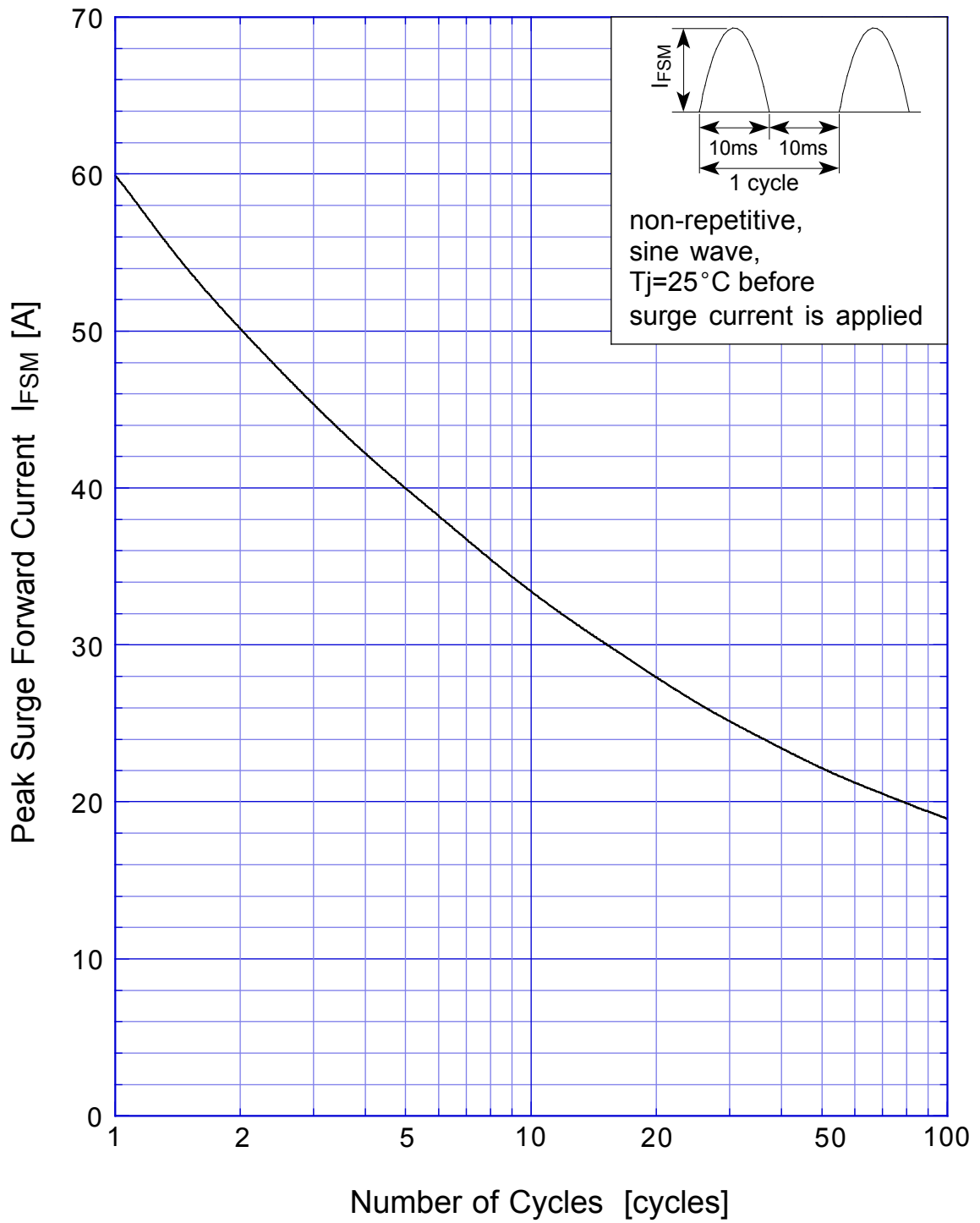

S2Vx Transient Thermal Impedance

