

SAI Series

Surface-Mount, Separate Excitation Switching Type

Features

- Surface-mount package
- Output current: 0.4 to 0.5A
- High efficiency: 75 to 89%
- Requires only 4 external components
- Phase correction and output voltage adjustment performed internally
- Built-in reference oscillator (60kHz)
- Built-in overcurrent and thermal protection circuits

Applications

- Power supplies for telecommunication equipment
- Onboard local power supplies



Lineup

Part Number	SAI01	SAI02	SAI03	SAI04	SAI06
Vo(V)	5.0	3.3	12.0	15.0	9.0
Io(A)	0.5		0.4		

Absolute Maximum Ratings

Parameter	Symbol	Ratings	Unit
DC Input Voltage	V _{IN}	35	V
Power Dissipation	P _D	0.75	W
Junction Temperature	T _j	+125	°C
Storage Temperature	T _{stg}	-40 to +125	°C
SW Terminal Applied Reverse Voltage	V _{SW}	-1	V
Thermal Resistance(junction to case)	R _{th(j-c)}	20	°C/W

Recommended Operating Conditions

Parameter	Symbol	Ratings					Unit
		SAI01	SAI02	SAI03	SAI04	SAI06	
DC Input Voltage Range	V _{IN}	7 to 33	5.3 to 28	15 to 33	18 to 33	12 to 33	V
Output Current Range	I _o	0 to 0.5		0 to 0.4			A
Operating Junction Temperature Range	T _{jop}	-30 to +125					°C

Electrical Characteristics

(Ta=25°C)

Parameter	Symbol	Ratings															Unit
		SAI01			SAI02			SAI03			SAI04			SAI06			
		min.	typ.	max.	min.	typ.	max.	min.	typ.	max.	min.	typ.	max.	min.	typ.	max.	
Output Voltage	Vo	4.80	5.00	5.20	3.17	3.30	3.43	11.40	12.00	12.60	14.25	15.00	15.75	8.55	9.00	9.45	V
	Conditions	VIN=20V, Io=0.3A			VIN=15V, Io=0.3A			VIN=24V, Io=0.3A			VIN=27V, Io=0.3A			VIN=21V, Io=0.3A			
Efficiency	η		80			75			88			89			86		%
	Conditions	VIN=20V, Io=0.3A			VIN=15V, Io=0.3A			VIN=24V, Io=0.3A			VIN=27V, Io=0.3A			VIN=21V, Io=0.3A			
Switching Frequency	f		60			60			60			60			60		kHz
	Conditions	VIN=20V, Io=0.3A			VIN=15V, Io=0.3A			VIN=24V, Io=0.3A			VIN=27V, Io=0.3A			VIN=21V, Io=0.3A			
Line Regulation	ΔV _{OLINE}		80	100		60	80		100	130		100	130		90	110	mV
	Conditions	VIN=10 to 30V, Io=0.3A			VIN=8 to 28V, Io=0.3A			VIN=18 to 30V, Io=0.3A			VIN=21 to 30V, Io=0.3A			VIN=15 to 30V, Io=0.3A			
Load Regulation	ΔV _{OLOAD}		30	40		20	30		70	95		90	120		50	80	mV
	Conditions	VIN=20V, Io=0.1 to 0.4A			VIN=15V, Io=0.1 to 0.4A			VIN=24V, Io=0.1 to 0.4A			VIN=27V, Io=0.1 to 0.4A			VIN=21V, Io=0.1 to 0.4A			
Temperature Coefficient of Output Voltage	ΔVo/ΔTa		±0.5			±0.5			±1.5			±1.5			±1.0		mV/°C
Ripple Rejection	R _{REJ}		45			45			45			45			45		dB
	Conditions	f=100 to 120Hz			f=100 to 120Hz			f=100 to 120Hz			f=100 to 120Hz			f=100 to 120Hz			
Overcurrent Protection	Is1	0.55			0.55			0.45			0.45			0.45			A
Starting Current	Conditions	VIN=10V			VIN=8V			VIN=18V			VIN=21V			VIN=15V			

Outline Drawing

(unit: mm)

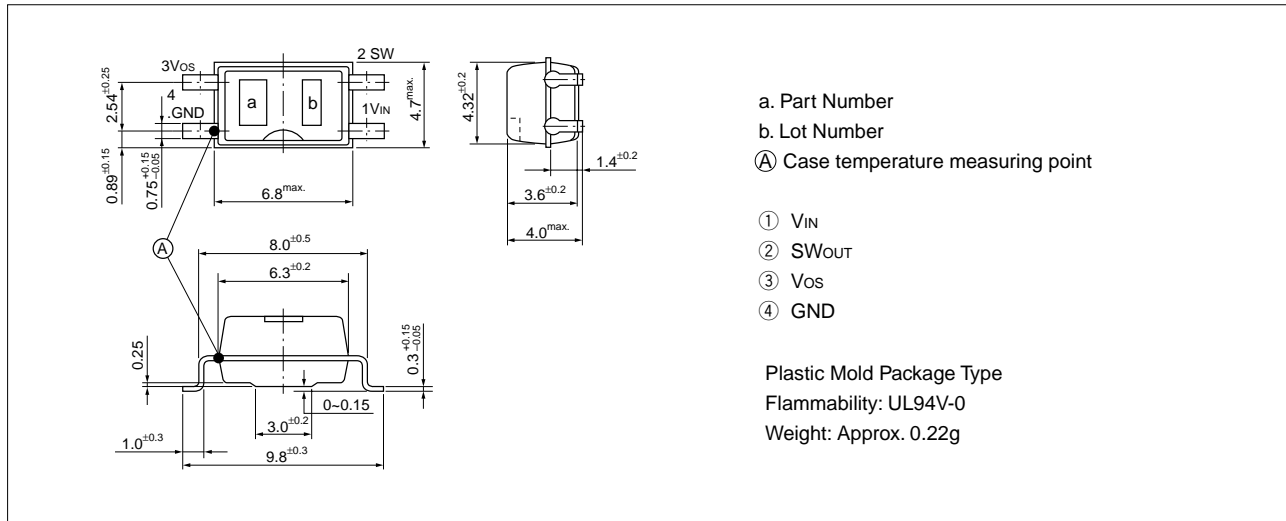

Block Diagram

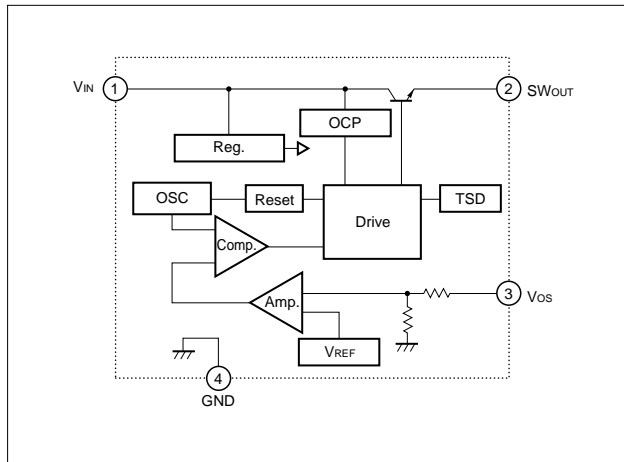

Standard External Circuit

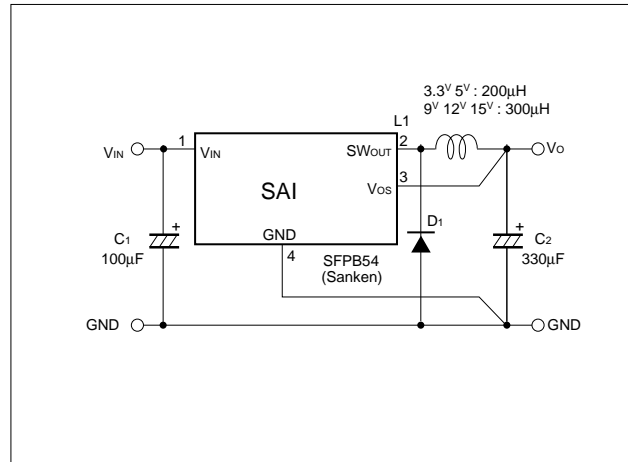

Example of Printed Circuit Board

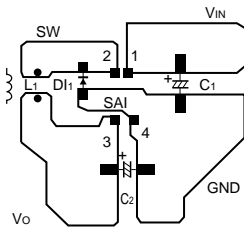

- a) For optimum operation, there must be only one GND line originating from terminal 4 and each component must be connected with the shortest possible wiring.
- b) To prevent heating of the IC, it is best to make the GND pattern as large as possible since the internal frame and terminal 4 (GND) are connected to each other.

Ta-Pd Characteristics

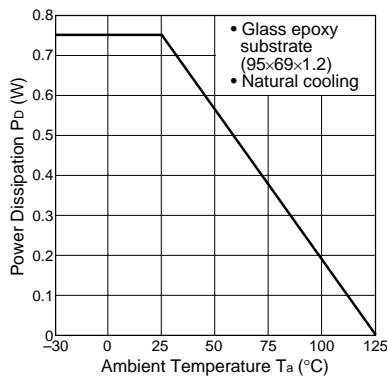

$$P_d = V_o \cdot I_o \left(\frac{100}{\eta\%} - 1 \right) - V_F \cdot I_o \left(1 - \frac{V_o}{V_{IN}} \right)$$

The efficiency depends on the input voltage and the output current. Thus, obtain the value from the efficiency graph on page 75 and substitute the percentage in the formula above.

- V_o: Output voltage
- I_o: Output current
- η%: Efficiency (%)
- V_F: Diode forward voltage
SFPB54-0.3V

Thermal design for D₁ must be considered separately.

Selecting External Components

1. Inductor L₁
 - 1) It must be suited for switching regulators.
Do not use inductors as noise filters as they generate excessive heat.
 - 2) It must have the appropriate inductance value.
If the inductance is too small (150μH or lower), abnormal oscillation may occur causing operation problems in the overcurrent protection circuit within the rated current range.
 - 3) The rated current must be satisfied.
If the rated current is exceeded, magnetic saturation leads to overcurrent.
2. Capacitors C₁ and C₂
 - 1) They must satisfy the withstand voltage and allowable ripple current.
Exceeding the ratings of these capacitors or using them without derating shortens their service lives and may also cause abnormal oscillation of the IC.
 - 2) C₂ must be a low-impedance type capacitor.
A low-impedance type capacitor is recommended for C₂ to ensure minimum ripple voltage and stable switching operation.
3. Diode D₁
The Sanken SFPB54 diode is recommended for D₁. If you intended to use an equivalent diode, be sure to use a Schottky Barrier diode and make sure that the reverse voltage applied to terminal 2 of the IC does not exceed the value (-1V) given in the absolute maximum ratings. If you use a fast recovery diode or any other diode, application of a reverse voltage generated from the recovery or ON voltage of the diode may damage the IC.

Application

Variable output voltage
Output voltage can be adjusted in the same way as SI-8000S in page 85.

Typical Characteristics

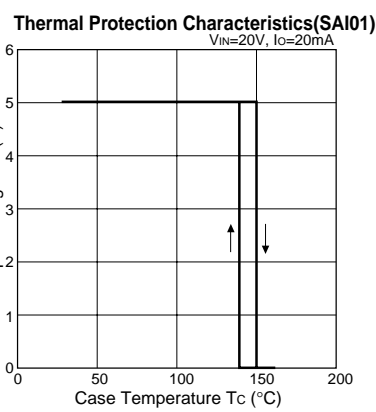
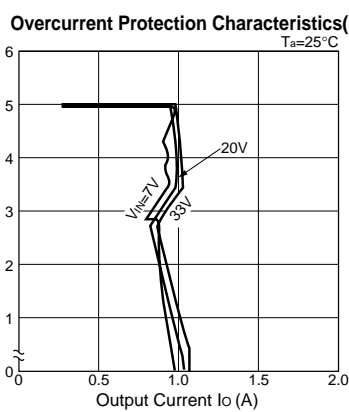
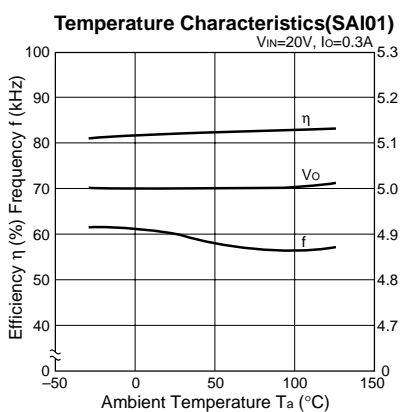
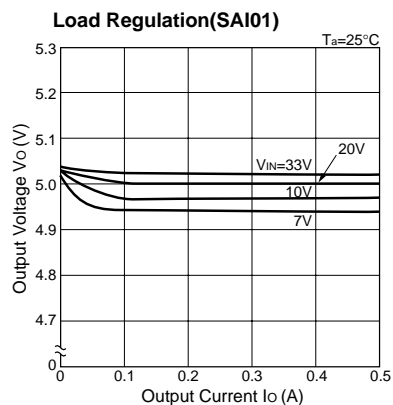
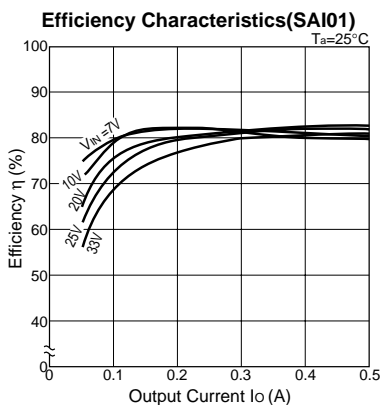
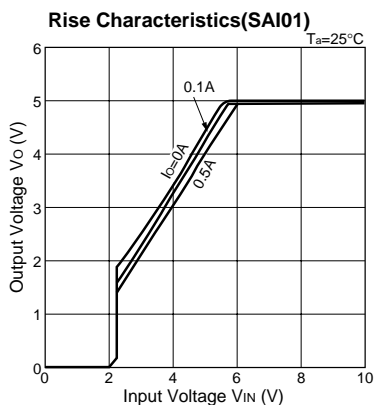

Note on Thermal Protection:

The thermal protection circuit is intended for protection against heat during instantaneous short-circuiting. Its operation is not guaranteed for short-circuiting over extended periods of time.

