

SCAN182541A

Non-Inverting Line Driver with 25Ω Series Resistor Outputs

General Description

The SCAN182541A is a high performance BiCMOS line driver featuring separate data inputs organized into dual 9-bit bytes with byte-oriented paired output enable control signals. This device is compliant with IEEE 1149.1 Standard Test Access Port and Boundary-Scan architecture with the incorporation of the defined Boundary-Scan test logic and test access port consisting of Test Data Input (TDI), Test Data Out (TDO), Test Mode Select (TMS), and Test Clock (TCK).

Features

- IEEE 1149.1 (JTAG) Compliant

- High performance BiCMOS technology
- 25Ω series resistor outputs eliminate need for external terminating resistors
- Dual output enable signals per byte
- 3-STATE outputs for bus-oriented applications
- 25 mil pitch SSOP (Shrink Small Outline Package)
- Includes CLAMP, IDCODE and HIGHZ instructions
- Additional instructions SAMPLE-IN, SAMPLE-OUT and EXTEST-OUT
- Power up 3-STATE for hot insert
- Member of Fairchild's SCAN Products

Ordering Code:

Connection Diagram

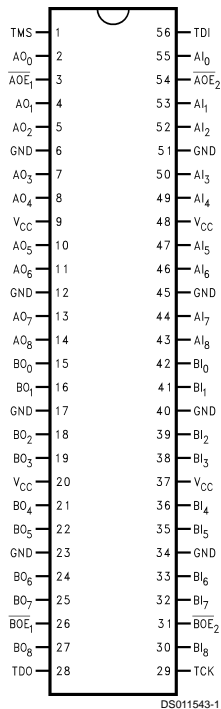

Pin Names	Description
Al ₍₀₋₈₎	Input Pins, A Side
Bl ₍₀₋₈₎	Input Pins, B Side
\overline{AOE}_1 , \overline{AOE}_2	3-STATE Output Enable Input Pins, A Side
\overline{BOE}_1 , \overline{BOE}_2	3-STATE Output Enable Input Pins, B Side
AO ₍₀₋₈₎	Output Pins, A Side
BO ₍₀₋₈₎	Output Pins, B Side

Order Number	Description
SCAN182541ASSC	SSOP in Tubes
SCAN182541ASSCX	SSOP in Tape and Reel
SCAN182541AFMQB	Flatpak Military

SCAN182541A Non-Inverting Line Driver with 25Ω Series Resistor Outputs

Truth Tables

Inputs			AO ₍₀₋₈₎
$\uparrow\overline{AOE}_1$	$\uparrow\overline{AOE}_2$	AI ₍₀₋₈₎	
L	L	H	H
H	X	X	Z
X	H	X	Z
L	L	L	L

Inputs			BO ₍₀₋₈₎
$\uparrow\overline{BOE}_1$	$\uparrow\overline{BOE}_2$	BI ₍₀₋₈₎	
L	L	H	H
H	X	X	Z
X	H	X	Z
L	L	L	L

H= HIGH Voltage Level
 L= LOW Voltage Level
 X= Immaterial
 Z= High Impedance
 \uparrow = Inactive-to-active transition must occur
 to enable outputs upon power-up.

Block Diagrams

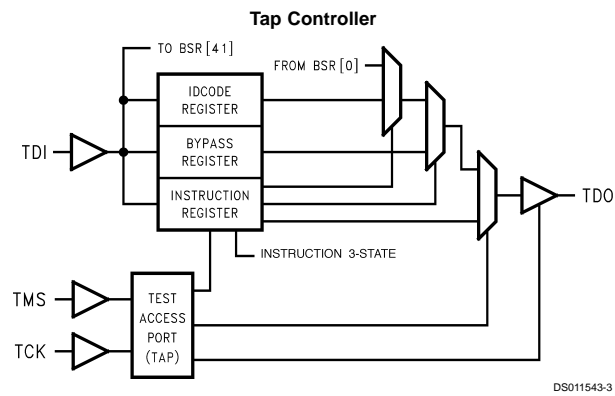
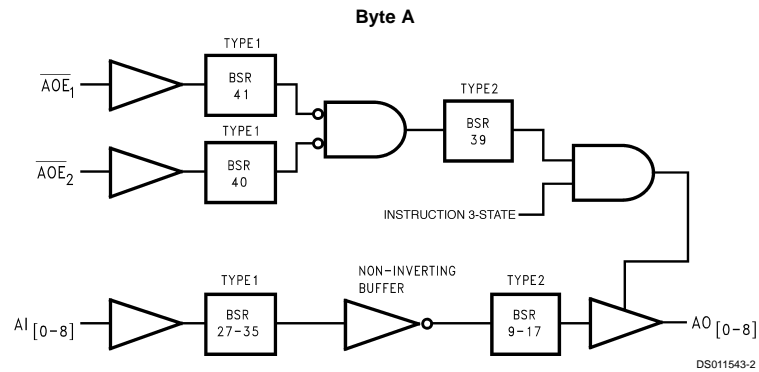

Block Diagrams (Continued)

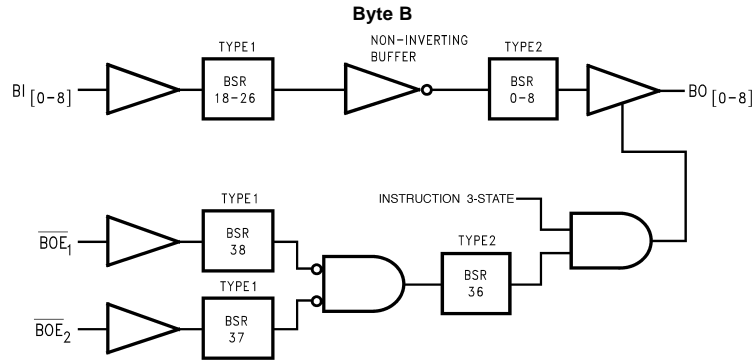

DS011543-4

Note: BSR stands for Boundary Scan Register.

Description of BOUNDARY-SCAN Circuitry

The scan cells used in the BOUNDARY-SCAN register are one of the following two types depending upon their location. Scan cell TYPE1 is intended to solely observe system data, while TYPE2 has the additional ability to control system data. (See IEEE Standard 1149.1 *Figure 10-11* for a further description of scan cell TYPE1 and *Figure 10-12* for a further description of scan cell TYPE2.)

Scan cell TYPE1 is located on each system input pin while scan cell TYPE2 is located at each system output pin as well as at each of the two internal active-high output enable signals. AOE controls the activity of the A-outputs while BOE controls the activity of the B-outputs. Each will activate their respective outputs by loading a logic high.

The BYPASS register is a single bit shift register stage identical to scan cell TYPE1. It captures a fixed logic low.

The INSTRUCTION register is an 8-bit register which captures the default value of 10000001 (SAMPLE/PRELOAD) during the CAPTURE-IR instruction command. The benefit of capturing SAMPLE/PRELOAD as the default instruction during CAPTURE-IR is that the user is no longer required to shift in the 8-bit instruction for SAMPLE/PRELOAD. The sequence of: CAPTURE-IR → EXIT1-IR → UPDATE-IR will update the SAMPLE/PRELOAD instruction. For more information refer to the section on instruction definitions.

Instruction Register Scan Chain Definition

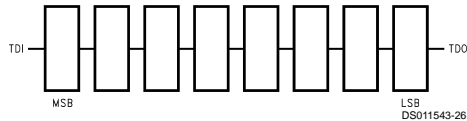

DS011543-26

Bypass Register Scan Chain Definition Logic 0

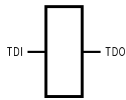

DS011543-17

SCAN182541A Product IDCODE (32-Bit Code per IEEE 1149.1)

Version	Entity	Part Number	Manufacturer ID	Required by 1149.1
0000	111111	0000001001	00000001111	1
MSB				LSB

MSB → LSB

Instruction Code	Instruction
00000000	EXTEST
10000001	SAMPLE/PRELOAD
10000010	CLAMP
00000011	HIGH-Z
01000001	SAMPLE-IN
01000010	SAMPLE-OUT
00100010	EXTEST-OUT
10101010	IDCODE
11111111	BYPASS
All Others	BYPASS

Description of BOUNDARY-SCAN Circuitry (Continued)

Scan Cell TYPE1

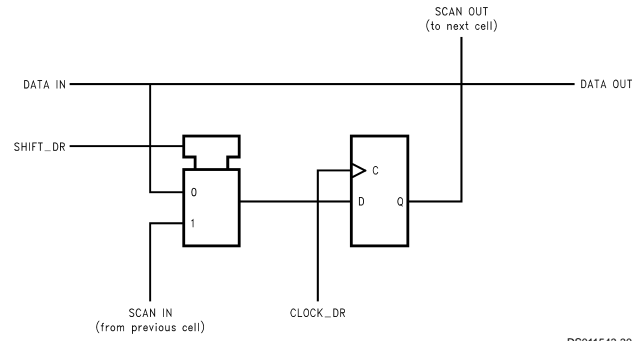

Scan Cell TYPE2

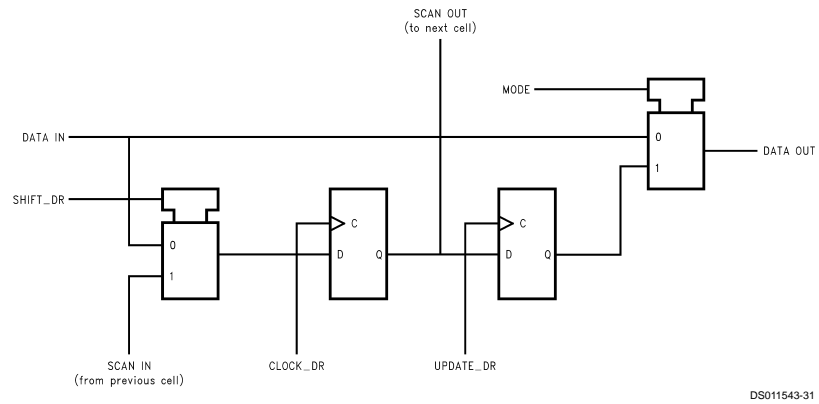

Description of BOUNDARY-SCAN Circuitry (Continued)

BOUNDARY-SCAN Register Scan Chain Definition (42 Bits in Length)

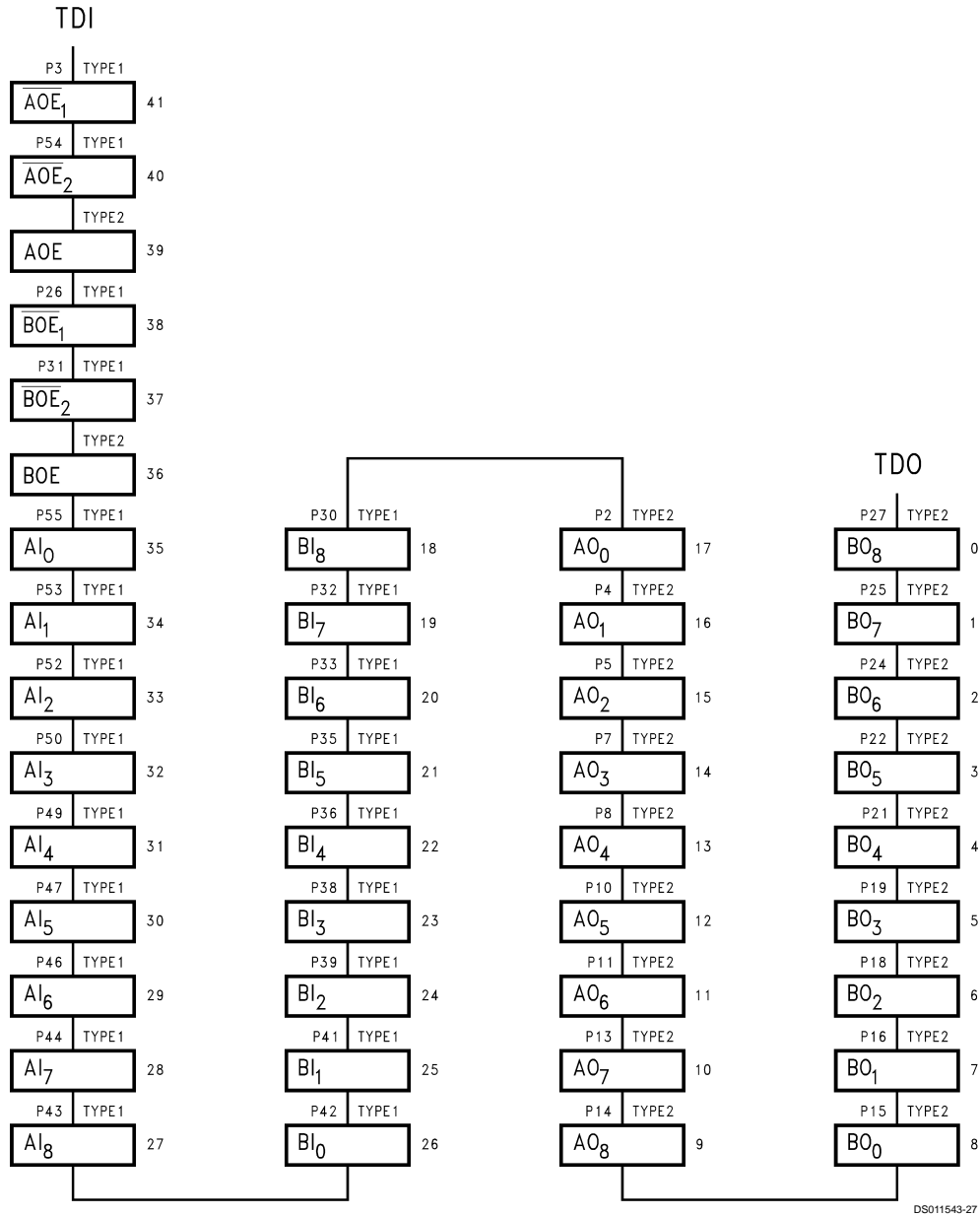

Description of BOUNDARY-SCAN Circuitry (Continued)

Input BOUNDARY-SCAN Register Scan Chain Definition (22 Bits in Length) When SAMPLE-IN is Active

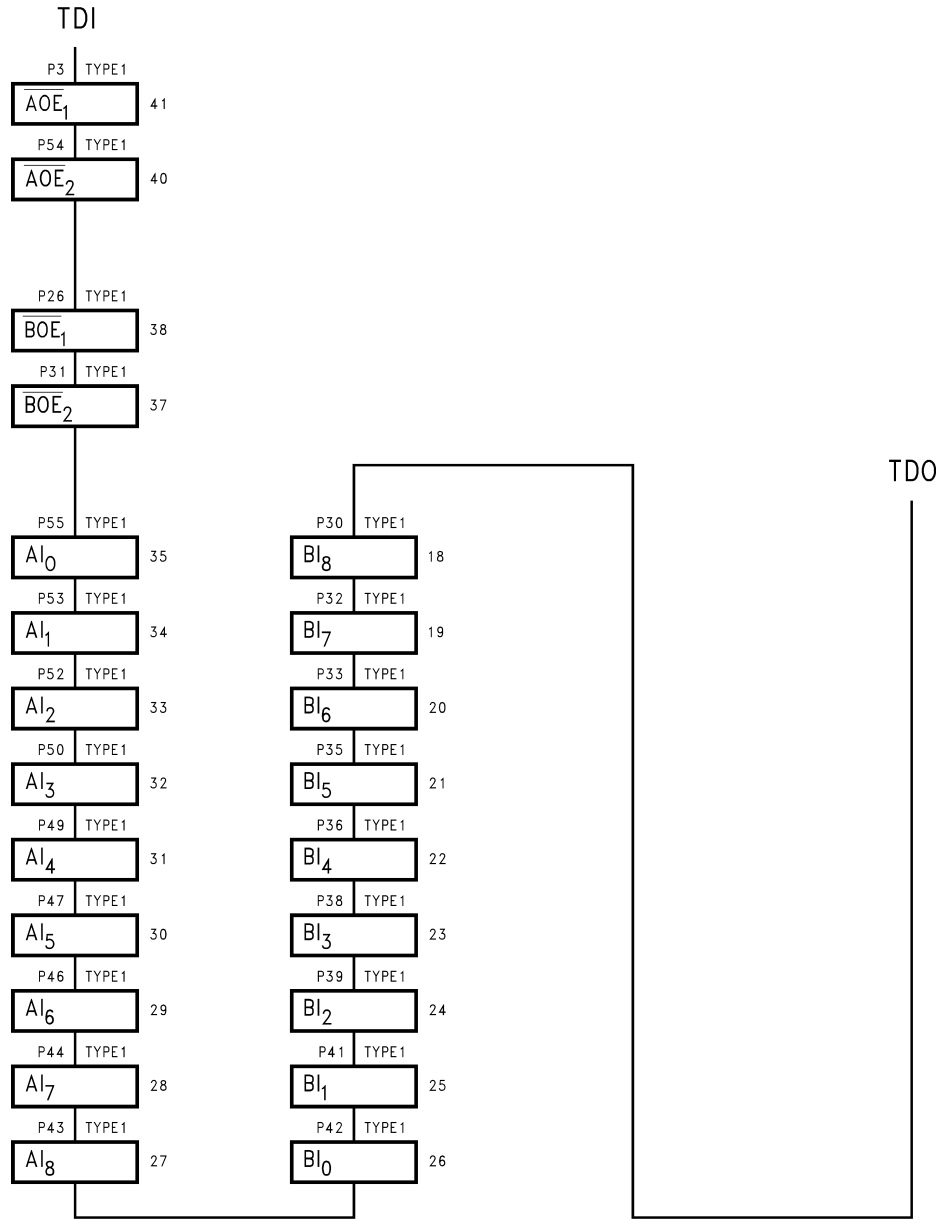

DS011543-28

Description of BOUNDARY-SCAN Circuitry (Continued)

Output BOUNDARY-SCAN Register
 Scan Chain Definition (20 Bits in Length)
 When SAMPLE-OUT and EXTEXT Out are Active

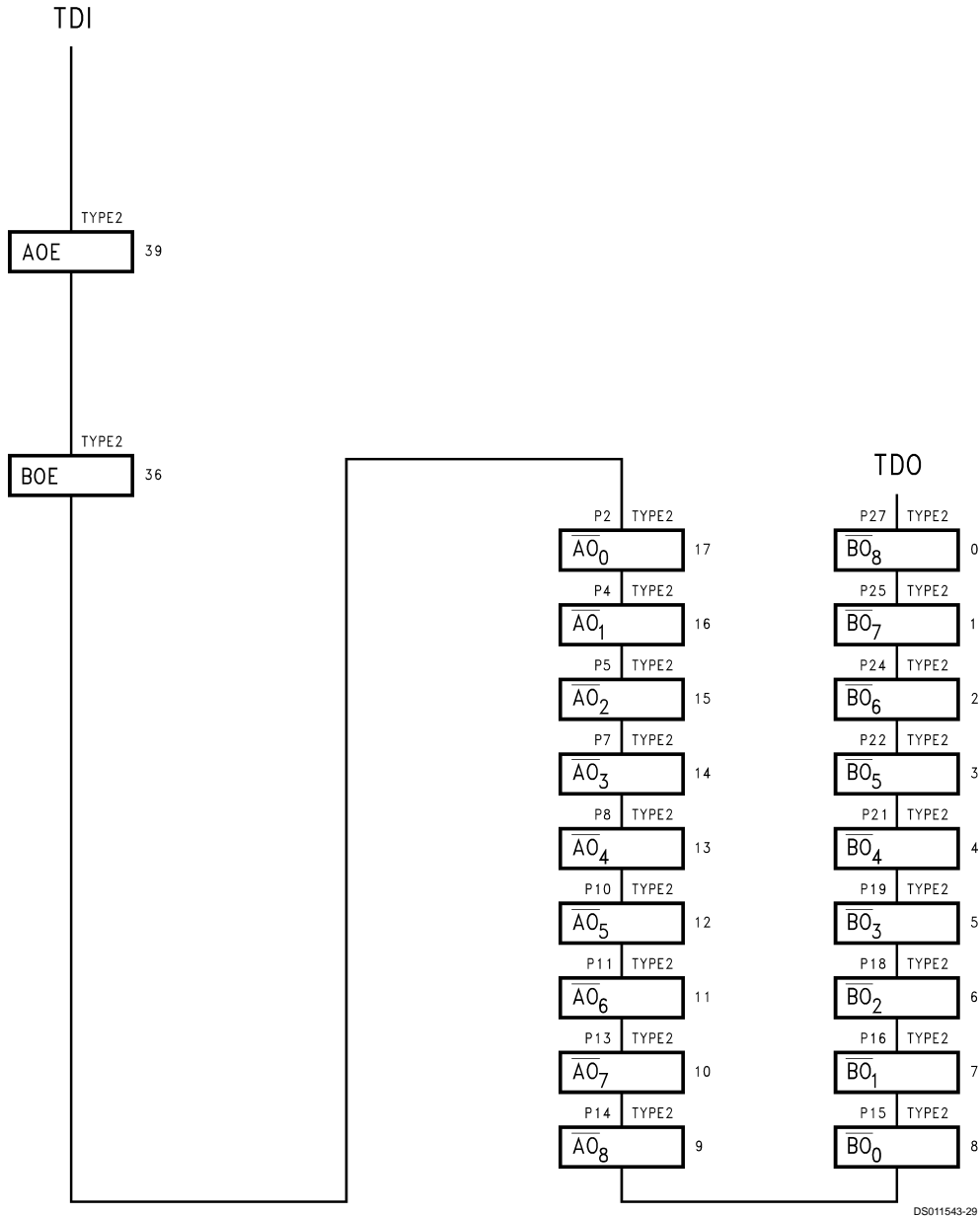

Description of BOUNDARY-SCAN Circuitry (Continued)

BOUNDARY-SCAN Register Definition Index

Bit No.	Pin Name	Pin No.	Pin Type	Scan Cell Type	
41	\overline{AOE}_1	3	Input	TYPE1	Control Signals
40	\overline{AOE}_2	54	Input	TYPE1	
39	AOE		Internal	TYPE2	
38	\overline{BOE}_1	26	Input	TYPE1	
37	\overline{BOE}_2	31	Input	TYPE1	
36	BOE		Internal	TYPE2	
35	AI ₀	55	Input	TYPE1	A-in
34	AI ₁	53	Input	TYPE1	
33	AI ₂	52	Input	TYPE1	
32	AI ₃	50	Input	TYPE1	
31	AI ₄	49	Input	TYPE1	
30	AI ₅	47	Input	TYPE1	
29	AI ₆	46	Input	TYPE1	
28	AI ₇	44	Input	TYPE1	
27	AI ₈	43	Input	TYPE1	
26	BI ₀	42	Input	TYPE1	B-in
25	BI ₁	41	Input	TYPE1	
24	BI ₂	39	Input	TYPE1	
23	BI ₃	38	Input	TYPE1	
22	BI ₄	36	Input	TYPE1	
21	BI ₅	35	Input	TYPE1	
20	BI ₆	33	Input	TYPE1	
19	BI ₇	32	Input	TYPE1	
18	BI ₈	30	Input	TYPE1	
17	AO ₀	2	Output	TYPE2	A-out
16	AO ₁	4	Output	TYPE2	
15	AO ₂	5	Output	TYPE2	
14	AO ₃	7	Output	TYPE2	
13	AO ₄	8	Output	TYPE2	
12	AO ₅	10	Output	TYPE2	
11	AO ₆	11	Output	TYPE2	
10	AO ₇	13	Output	TYPE2	
9	AO ₈	14	Output	TYPE2	
8	BO ₀	15	Output	TYPE2	B-out
7	BO ₁	16	Output	TYPE2	
6	BO ₂	18	Output	TYPE2	
5	BO ₃	19	Output	TYPE2	
4	BO ₄	21	Output	TYPE2	
3	BO ₅	22	Output	TYPE2	
2	BO ₆	24	Output	TYPE2	
1	BO ₇	25	Output	TYPE2	
0	BO ₈	27	Output	TYPE2	

Absolute Maximum Ratings (Note 1)

Storage Temperature	-65°C to +150°C
Ambient Temperature under Bias	-55°C to +125°C
Junction Temperature under Bias	
Ceramic	-55°C to +175°C
Plastic	-55°C to +150°C
V _{CC} Pin Potential to Ground Pin	-0.5V to +7.0V
Input Voltage (Note 2)	-0.5V to +7.0V
Input Current (Note 2)	-30 mA to +5.0 mA
Voltage Applied to Any Output in the Disabled or Power-Off State	-0.5V to +5.5V
in the HIGH State	-0.5V to V _{CC}
Current Applied to Output in LOW State (Max)	Twice the Rated I _{OL} (mA)
DC Latchup Source Current Commercial	-500 mA

Military	-300 mA
Over Voltage Latchup (I/O)	10V
EDS (HBM) Min	2000V

Recommended Operating Conditions

Free Air Ambient Temperature	
Military	-55°C to +125°C
Commercial	-40°C to +85°C
Supply Voltage	
Military	+4.5V to +5.5V
Commercial	+4.5V to +5.5V
Minimum Input Edge Rate	($\Delta V/\Delta t$)
Data Input	50 mV/ns
Enable Input	20 mV/ns

Note 1: Absolute Maximum Ratings are values beyond which the device may be damaged or have its useful life impaired. Functional operation under these conditions is not implied.

DC Electrical Characteristics

Symbol	Parameter	V _{CC}	Min	Typ	Max	Units	Conditions
V _{IH}	Input HIGH Voltage		2.0			V	Recognized HIGH Signal
V _{IL}	Input LOW Voltage				0.8	V	Recognized LOW Signal
V _{CD}	Input Clamp Diode Voltage	Min			-1.2	V	I _{IN} = -18 mA
V _{OH}	Output HIGH Voltage	Min	2.5			V	I _{OH} = -3 mA
		Mil	2.0			V	I _{OH} = -24 mA
		Comm	2.0			V	I _{OH} = -32 mA
V _{OL}	Output LOW Voltage	Mil			0.8	V	I _{OL} = 12 mA
		Comm			0.8	V	I _{OL} = 15 mA
I _{IH}	Input HIGH Current	All Others	Max		5	μA	V _{IN} = 2.7V (Note 3)
			Max		5	μA	V _{IN} = V _{CC}
		TMS, TDI	Max		5	μA	V _{IN} = V _{CC}
I _{BVI}	Input HIGH Current Breakdown Test	Max		7	μA	V _{IN} = 7.0V	
I _{BVIT}	Input HIGH Current Breakdown Test (I/O)	Max		100	μA	V _{IN} = 5.5V	
I _{IL}	Input LOW Current	All Others	Max		-5	μA	V _{IN} = 0.5V (Note 3)
			Max		-5	μA	V _{IN} = 0.0V
		TMS, TDI	Max		-385	μA	V _{IN} = 0.0V
V _{ID}	Input Leakage Test	0.0	4.75			V	I _{ID} = 1.9 μA All Other Pins Grounded
I _{IH} + I _{OZH}	Output Leakage Current	Max		50	μA	V _{OUT} = 2.7V	
I _{IL} + I _{OZL}	Output Leakage Current	Max		-50	μA	V _{OUT} = 0.5V	
I _{OZH}	Output Leakage Current	Max		50	μA	V _{OUT} = 2.7V	
I _{OZL}	Output Leakage Current	Max		-50	μA	V _{OUT} = 0.5V	
I _{OS}	Output Short-Circuit Current	Max	-100	-275	mA	V _{OUT} = 0.0V	
I _{CEX}	Output HIGH Leakage Current	Max		50	μA	V _{OUT} = V _{CC}	
I _{ZZ}	Bus Drainage Test	0.0		100	μA	V _{OUT} = 5.5V All Others Grounded	
I _{CCH}	Power Supply Current	Max		250	μA	V _{OUT} = V _{CC} ; TDI, TMS = V _{CC}	
		Max		1.0	mA	V _{OUT} = V _{CC} ; TDI, TMS = GND	

DC Electrical Characteristics (Continued)

Symbol	Parameter	V _{CC}	Min	Typ	Max	Units	Conditions	
I _{CCL}	Power Supply Current	Max		65		mA	V _{OUT} = LOW; TDI, TMS = V _{CC}	
				65.8		mA	V _{OUT} = LOW; TDI, TMS = GND	
I _{CCZ}	Power Supply Current	Max		250		μA	TDI, TMS = V _{CC}	
				1.0		mA	TDI, TMS = GND	
I _{CC1}	Additional I _{CC} /Input		All Other Inputs TDI, TMS Inputs	Max		2.9	mA	V _{IN} = V _{CC} - 2.1V
						3		mA
I _{CCD}	Dynamic I _{CC}				0.2	mA/ MHz	Outputs Open One Bit Toggling, 50% Duty Cycle	

Note 2: Either voltage limit or current limit is sufficient to protect inputs.

Note 3: Guaranteed not tested.

AC Electrical Characteristics

Normal Operation:

Symbol	Parameter	V _{CC} (V) (Note 4)	Military			Commercial			Units
			T _A = -55°C to +125°C			T _A = -40°C to +85°C			
			C _L = 50 pF			C _L = 50 pF			
			Min	Typ	Max	Min	Typ	Max	
t _{PLH}	Propagation Delay	5.0				1.0	3.4	5.2	ns
t _{PHL}	Data to Q					1.9	4.1	6.5	
t _{PLZ}	Disable Time	5.0				2.0	5.2	8.7	ns
t _{PHZ}						1.9	5.6	9.2	
t _{PZL}	Enable Time	5.0				2.4	6.1	9.6	ns
t _{PZH}						1.6	5.1	8.5	
t _{PLH}	Propagation Delay	5.0				3.2	6.0	9.4	ns
t _{PHL}	TCK to TDO					4.5	7.6	11.3	
t _{PLZ}	Disable Time	5.0				2.5	5.8	9.9	ns
t _{PHZ}	TCK to TDO					3.7	7.4	11.8	
t _{PZL}	Enable Time	5.0				4.9	8.6	12.9	ns
t _{PZH}	TCK to TDO					3.1	6.7	10.7	
t _{PLH}	Propagation Delay					3.7	6.7	10.3	ns
t _{PHL}	TCK to Data Out during Update-DR State	5.0				4.9	8.3	12.4	
t _{PLH}	Propagation Delay					4.2	7.9	12.2	ns
t _{PHL}	TCK to Data Out during Update-IR State	5.0				5.3	9.2	13.8	
t _{PLH}	Propagation Delay					5.0	9.4	14.6	ns
t _{PHL}	TCK to Data Out during Test Logic Reset State	5.0				6.2	10.9	16.4	
t _{PLZ}	Disable Time					3.7	7.9	13.0	ns
t _{PHZ}	TCK to Data Out during Update-DR State	5.0				4.3	8.7	13.7	
t _{PLZ}	Disable Time					3.7	8.5	14.2	ns
t _{PHZ}	TCK to Data Out during Update-IR State	5.0				4.3	9.4	14.8	
t _{PLZ}	Disable Time TCK to Data Out during Test Logic Reset State					4.7	10.1	16.6	ns
t _{PHZ}		5.0				5.5	10.9	17.3	

AC Electrical Characteristics (Continued)

Normal Operation:

Symbol	Parameter	V _{CC} (V) (Note 4)	Military			Commercial			Units
			T _A = -55°C to +125°C			T _A = -40°C to +85°C			
			C _L = 50 pF			C _L = 50 pF			
Min	Typ	Max	Min	Typ	Max				
t _{PZL}	Enable Time	5.0				5.5	9.8	14.7	ns
t _{PZH}	TCK to Data Out during Update-DR State					4.0	7.9	12.5	
t _{PZL}	Enable Time	5.0				5.8	10.9	16.5	ns
t _{PZH}	TCK to Data Out during Update-IR State					4.3	9.0	14.4	
t _{PZL}	Enable Time	5.0				6.6	12.5	19.1	ns
t _{PZH}	TCK to Data Out during Test Logic Reset State					4.9	10.5	16.9	

Note 4: Voltage Range 5.0V ±0.5V

AC Operating Requirements

Scan Test Operation:

Symbol	Parameter	V _{CC} (V) (Note 5)	Military		Commercial		Units
			T _A = -55°C to +125°C		T _A = -40°C to +85°C		
			C _L = 50 pF		C _L = 50 pF		
			Guaranteed Minimum				
t _S	Setup Time Data to TCK (Note 8)	5.0			2.2		ns
t _H	Hold Time Data to TCK (Note 8)	5.0			1.8		ns
t _S	Setup Time, H or L AOE _n , BOE _n to TCK (Note 7)	5.0			3.7		ns
t _H	Hold Time, H or L TCK to AOE _n , BOE _n (Note 7)	5.0			1.8		ns
t _S	Setup Time, H or L Internal AOE _n , BOE _n , to TCK (Note 9)	5.0			2.7		ns
t _H	Hold Time, H or L TCK to Internal AOE _n , BOE _n (Note 9)	5.0			1.8		ns
t _S	Setup Time, H or L TMS to TCK	5.0			7.5		ns
t _H	Hold Time, H or L TCK to TMS	5.0			1.8		ns
t _S	Setup Time, H or L TDI to TCK	5.0			5.0		ns
t _H	Hold Time, H or L TCK to TDI	5.0			2.0		ns
t _w	Pulse Width TCK	H L	5.0		10.0 10.8		ns
f _{max}	Maximum TCK Clock Frequency		5.0		50		MHz
t _{PU}	Wait Time, Power Up to TCK		5.0		100		ns

AC Operating Requirements (Continued)

Scan Test Operation:

Symbol	Parameter	V _{CC} (V) (Note 5)	Military	Commercial	Units
			T _A = -55°C to +125°C C _L = 50 pF	T _A = -40°C to +85°C C _L = 50 pF	
			Guaranteed Minimum		
t _{DN}	Power Down Delay	0.0		100	ms

Note 5: Voltage Range 5.0V ±0.5V

Note 6: All Input Timing Delays involving TCK are measured from the rising edge of TCK.

Note 7: Timing pertains to BSR 38 and 41 or BSR 37 and 40.

Note 8: This delay represents the timing relationship between the data input and TCK at the associated scan cells numbered 0-8, 9-17, 18-26 and 27-35.

Note 9: This delay represents the timing relationship between AOE/BOE and TCK for scan cells 36 and 39 only.

Capacitance

Symbol	Parameter	Typ	Units	Conditions, T _A = 25°C
C _{IN}	Input Capacitance	5.8	pF	V _{CC} = 0.0V
C _{OUT} (Note 10)	Output Capacitance	13.8	pF	V _{CC} = 5.0V

Note 10: C_{OUT} is measured at frequency f = 1 MHz, per MIL-STD-883B, Method 3012.

Ordering Information

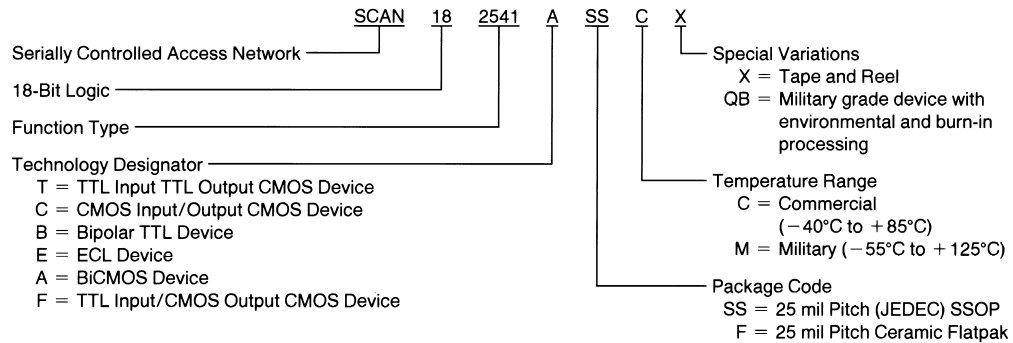

DS011543-32

Physical Dimensions inches (millimeters) unless otherwise noted

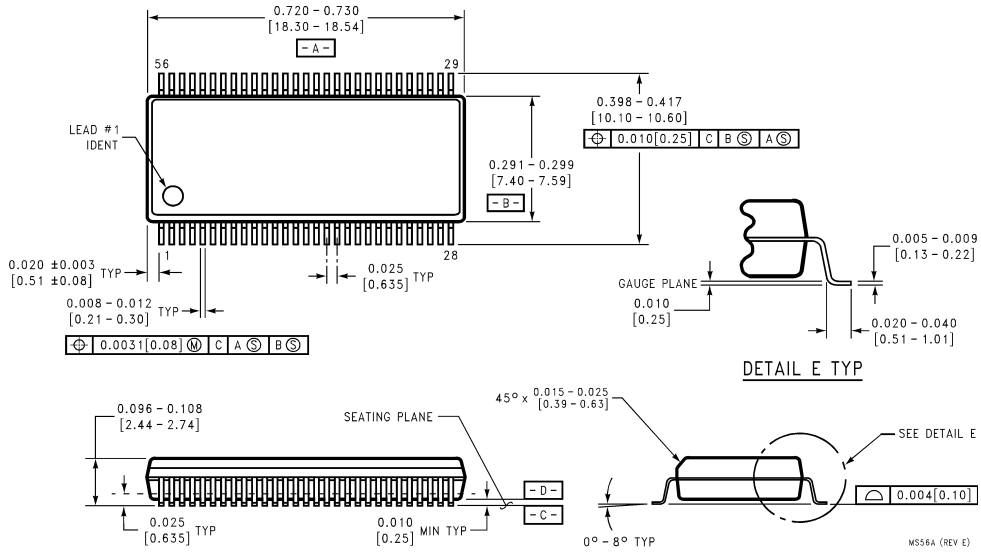

56-Lead SSOP (0.300" Wide) (SS)
Order Number SCAN182541ASSC or SCAN182541ASSCX
Package Number MS56A

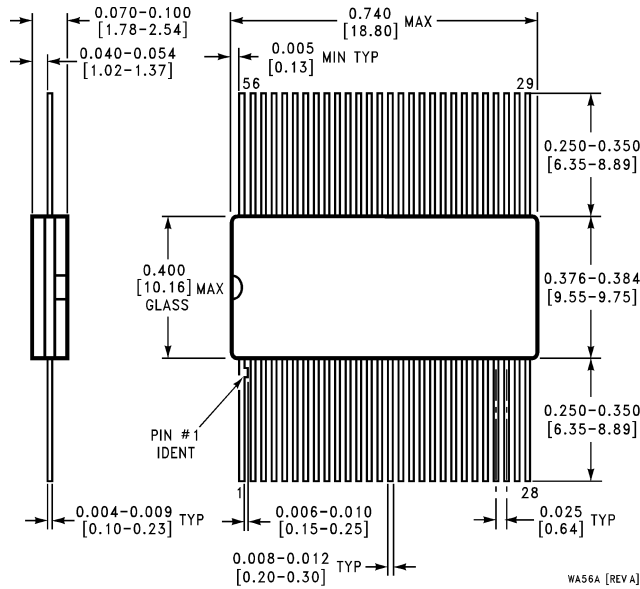

56-Lead Ceramic Flatpak (F)
Order Number SCAN182541AFMQB
Package Number WA56A

LIFE SUPPORT POLICY

FAIRCHILD'S PRODUCTS ARE NOT AUTHORIZED FOR USE AS CRITICAL COMPONENTS IN LIFE SUPPORT DEVICES OR SYSTEMS WITHOUT THE EXPRESS WRITTEN APPROVAL OF THE PRESIDENT OF FAIRCHILD SEMICONDUCTOR CORPORATION. As used herein:

1. Life support devices or systems are devices or systems which, (a) are intended for surgical implant into the body, or (b) support or sustain life, and (c) whose failure to perform when properly used in accordance with instructions for use provided in the labeling, can be reasonably expected to result in a significant injury to the user.
2. A critical component in any component of a life support device or system whose failure to perform can be reasonably expected to cause the failure of the life support device or system, or to affect its safety or effectiveness.

Fairchild Semiconductor Corporation Americas
Customer Response Center
Tel: 1-888-522-5372
Fax: 972-910-8036

Fairchild Semiconductor Europe
Fax: +49 (0) 1 80-530 85 86
Email: europe.support@nsc.com
Deutsch Tel: +49 (0) 8 141-35-0
English Tel: +44 (0) 1 793-85-68-56
Italy Tel: +39 (0) 2 57 5631

Fairchild Semiconductor Hong Kong Ltd.
8/F Room 808 Empire Centre
68 Mody Road, Tsimshatsui East
Kowloon, Hong Kong
Tel: 852-2722-8338
Fax: 852-2722-8383

Fairchild Semiconductor Japan Ltd.
4F, Natsume Bldg,
2-18-6 Yushima, Bunkyo-ku,
Tokyo 113-0034, Japan
Tel: 81-3-3818-8840
Fax: 81-3-3818-8450

www.fairchildsemi.com