

SDI02

2-Output, Low Dropout Voltage Dropper Type for USB

Features

- Two 5V/0.5A output regulators in one package
- Surface-mount 16 pin package
- Low dropout voltage: $V_{DIF} \leq 0.5V$ (at $I_o = 0.5A$)
- Output-independent ON/OFF control terminal compatible with LS-TTL (Active High)
- Built in output-independent overcurrent and thermal protection circuits
- Open collector flag-output terminals built in to output OCP operation to each output terminal (Active Low)
- Built-in anti-malfunction delay circuit whose time can be set with an external capacitor

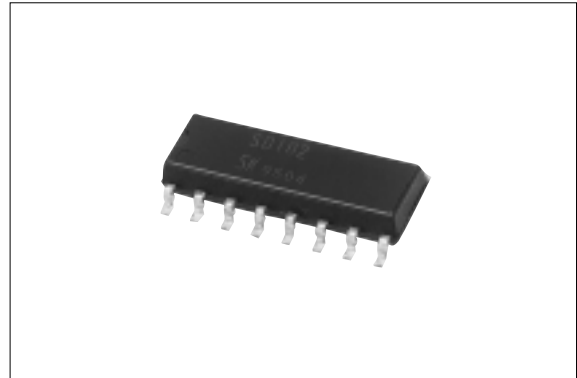

Applications

- USB power supplies
- Electronic equipment

Absolute Maximum Ratings

($T_a=25^\circ C$)

Parameter	Symbol	Ratings	Unit
DC Input Voltage	V_{IN}	18	V
Voltage of Output Control Terminal	V_C	V_{IN}	V
DC Output Current	I_o	0.5	A
Power Dissipation	P_D	3.1*1	W
Junction Temperature	T_j	-30 to +125	$^\circ C$
Ambient Operating Temperature	T_{OP}	-30 to +100	$^\circ C$
Storage Temperature	T_{stg}	-30 to +125	$^\circ C$
Thermal Junction (junction-to-ambient air)	$R_{th(j-a) 1}$	42*2	$^\circ C/W$
	$R_{th(j-a) 2}$	32*1	$^\circ C/W$
Thermal Junction (junction-to-lead)	$R_{th(j-l) 1}$	11*3	$^\circ C/W$
	$R_{th(j-l) 1}$	14*4	$^\circ C/W$

*1: With simultaneous operation of both two channels when mounted on glass-epoxy board 56.5mm x 56.5mm (copper foil area 50%).

*2: With operation of one channel when mounted on glass-epoxy board 56.5mm x 56.5mm (copper foil area 50%).

*3: Junction - to - pin 14 (CH1)

*4: Junction - to - pin 10 (CH2)

Recommended Operating Control

($T_a=25^\circ C$)

Parameter	Symbol	Ratings	Unit
DC Input Voltage Range	V_{IN}	5.5*1 to 8.0	V
Output Current Range	I_o	0 to +0.5	A
Ambient Operating Temperature	T_{aop}	-10 to +85	$^\circ C$
Junction Operating Temperature	T_{jop}	-10 to +100	$^\circ C$

*1: $V_{IN(min)}$ must be no less than the sum of output voltage and dropout voltage.

Electrical Characteristics

(T_a=25°C unless otherwise specified)

Parameter	Symbol	Ratings			Unit	
		min.	typ.	max.		
Output Voltage	V _o	4.85	5.00	5.15	V	
	Conditions	V _{IN} =7V, I _o =0.1A				
Dropout Voltage	V _{DIF}			0.5	V	
	Conditions	I _o ≤0.5A				
Line Regulation	ΔV _{OLINE}			30	mV	
	Conditions	V _{IN} =6 to 15V, I _o =0.1A				
Load Regulation	ΔV _{OLOAD}			50	mV	
	Conditions	V _{IN} =7V, I _o =0 to 0.5A				
Temperature Coefficient of Output Voltage	ΔV _o /ΔT _a		±0.5		mV/°C	
	Conditions	V _{IN} =7V, I _o =5mA, T _J =-10 to 100°C				
Quiescent Circuit Current	I _q			12* ¹	mA	
	Conditions	V _{IN} =7V, I _o =0A				
Quiescent Circuit Current (Output OFF)	I _{q (off)}			0.25 * ¹	mA	
	Conditions	V _{IN} =7V, V _{C1} and 2=0V				
Overcurrent Protection Starting Current* ¹	I _{s1}	0.75		0.96	A	
	Conditions	V _{IN} =7V				
V _C Terminal* ³	Control Voltage (Output ON)	V _{C, IH}	2.0		V	
	Control Voltage (Output OFF)	V _{C, IL}		0.7		
	Control Current (Output ON)	I _{C, IH}			50	μA
		Conditions	V _C =2.7V			
	Control Current (Output OFF)	I _{C, IL}			-100	μA
Conditions		V _C =0V				
OCP Detection	V _{oth}	3.7	4.0	4.3	V	
Delay Threshold Voltage	V _{DLYth}	2.1	2.3	2.5	V	
Delay Terminal Output Current	I _{DLY}	35	50	65	μA	
Flag Output Terminal	Before OCP Detection	V _{FLGh}	V _{IN} -0.4		V	
		Conditions	R _{FLG} connected between FLG and V _{IN}			
	After OCP Detection	V _{FLGi}			0.5	V
		Conditions	I _{FLG} =1mA			
FLG Reset Time * ⁴	t _{Reset}		1.2		μS	

*1: Total of two circuits

*2: I_{s1} is specified at -5 (%) drop point of output voltage V_o on the condition that V_{IN}=7V, I_o=0.1A.*3: Output is ON even when output control terminal V_C is open. Each input level is equivalent to LS-TTL. Therefore, it may be directly driven by an LS-TTL circuit.

*4: Refer to timing chart on p.103

External Dimensions

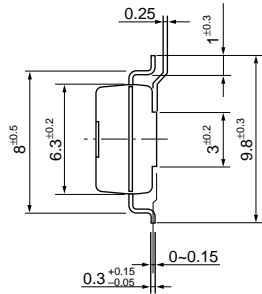
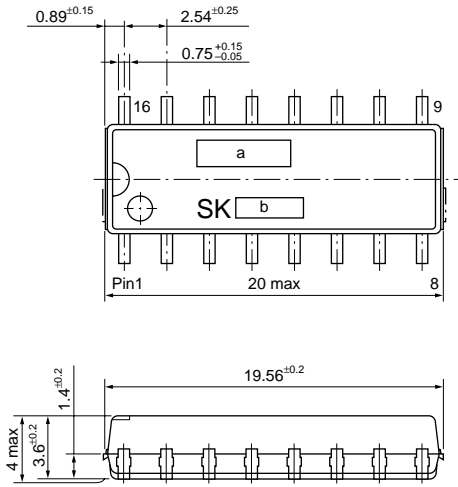

a. Part Number
b. Lot Number

Pin Arrangement

- | | |
|--------|--------|
| ① FLG1 | ⑨ GND2 |
| ② DLY1 | ⑩ GND2 |
| ③ Vo1 | ⑪ Vc2 |
| ④ VIN1 | ⑫ Vc2 |
| ⑤ FLG2 | ⑬ GND1 |
| ⑥ DLY2 | ⑭ GND1 |
| ⑦ Vo2 | ⑮ Vc1 |
| ⑧ VIN2 | ⑯ Vc1 |

Plastic Mold Package Type
Flammability: UL94V-0
Weight: Approx. 1.05g

Block Diagram

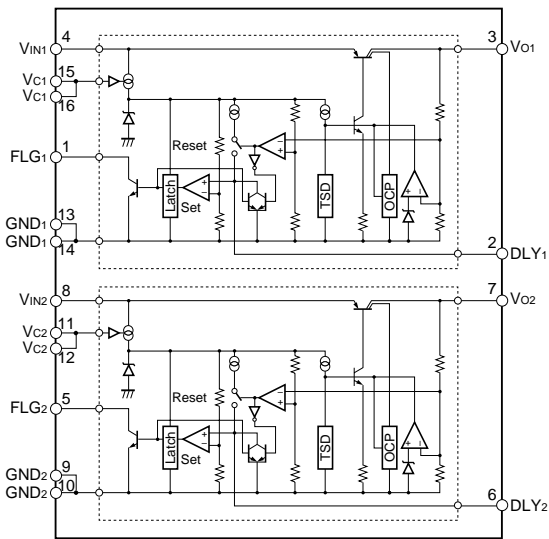

Standard External Circuit

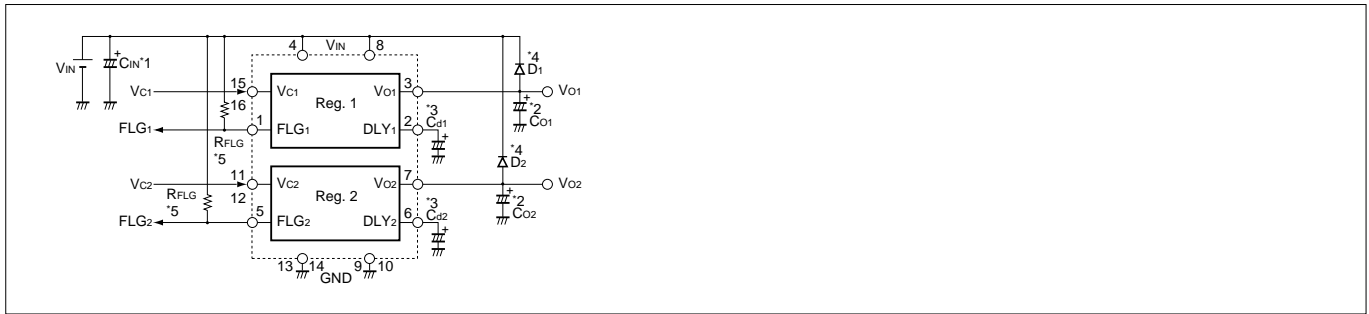

- *1 C_{IN} : Input capacitor (Approx. 47μF)
This capacitor is required if the input line is inductive and in the case of long wiring.
- *2 C_O : Output capacitor (47 to 220μF)
When used at low temperature (-10° or less), set to 100μF or more or use tantalum capacitor.
- *3 C_d : Delay time setting capacitor (0.1μF or more)
Use C_d to set the delay time (t_{DLY}) from when a low V_O level due to OCP operation is detected until a flag signal is output.
This prevents a rush current from causing malfunction at start.
Approximate calculation: $t_{DLY} \approx (C_d \times V_{DLYth}) / I_{DLY} [\text{sec}]$
When using soft start on V_{IN} or if C_{IN} has a large capacitance, set t_{DLY} long enough for the output voltage to rise sufficiently.
Be sure to connect C_d and do not use it for other applications, such as short circuiting C_d.

Timing chart

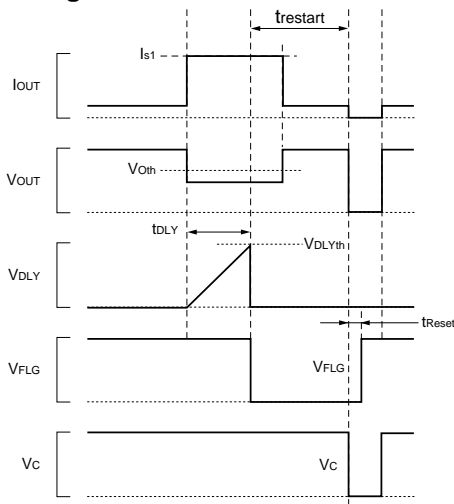

R_{FLG} connected between FLG and V_{IN}

FLG output operates after the time t_{DLY} has elapsed (the time set by DLY) after OCP is detected, and is latched. The latch can be reset by making V_C or V_{IN} low. Allow a time lag of C_d x 600 [sec] or more between setting and restarting.

- *4 D_{1, 2} : Reverse biasing protection diode.
This diode is required for protection against reverse biasing of the input and output.
- *5 R_{FLG} : Set this to limit the inflow current into the FLG terminal to 1mA or less.

T_a-P_d Characteristics

