

SHINDENGEN

Schottky Rectifiers (SBD)

Dual

SF20SC3L

30V 20A

FEATURES

- Tj150°C
- Low V_F= 0.45V
- P_{RRSM} avalanche guaranteed
- Fully Isolated Molding
- Dielectric strength 2kV guaranteed

APPLICATION

- Switching power supply
- DC/DC converter
- Home Appliances, Office Equipment
- Telecommunication

OUTLINE DIMENSIONS

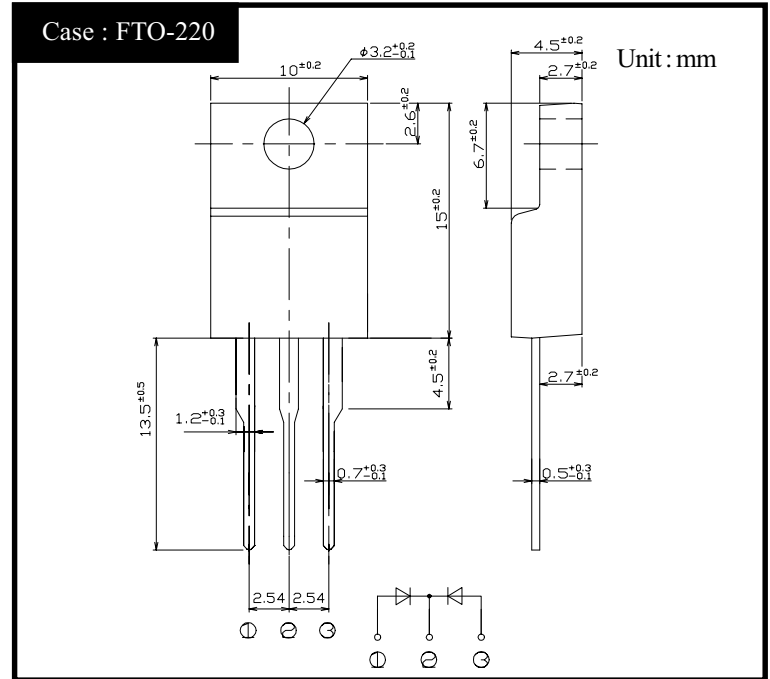

RATINGS

● Absolute Maximum Ratings (If not specified T_c=25°C)

Item	Symbol	Conditions	Ratings	Unit
Storage Temperature	T _{stg}		-55~150	°C
Operating Junction Temperature	T _j		150	°C
Maximum Reverse Voltage	V _{RM}		30	V
Repetitive Peak Surge Reverse Voltage	V _{RRSM}	Pulse width 0.5ms, duty 1/40	35	V
Average Rectified Forward Current	I _O	50Hz sine wave, R-load, With heatsink, Rating for each diode I _O /2, T _c =125°C	20	A
Peak Surge Forward Current	I _{FSM}	50Hz sine wave, Non-repetitive 1 cycle peak value, T _j =25°C	230	A
Repetitive Peak Surge Reverse Power	P _{RRSM}	Pulse width 10 μs, Rating of per diode, T _j =25°C	660	W
Dielectric Strength	V _{dis}	Terminals to case, AC 1 minute	2	kV
Mounting Torque	TOR	(Recommended torque: 0.3N·m)	0.5	N·m

● Electrical Characteristics (If not specified T_c=25°C)

Item	Symbol	Conditions	Ratings	Unit
Forward Voltage	V _F	I _F =8A, Pulse measurement, Rating of per diode	Max.0.45	V
Reverse Current	I _R	V _R =V _{RM} , Pulse measurement, Rating of per diode	Max.9	mA
Junction Capacitance	C _j	f=1MHz, V _R =10V, Rating of per diode	Typ.570	pF
Thermal Resistance	θ _{jc}	junction to case	Max.2.0	°C/W

SF20SC3L Forward Voltage

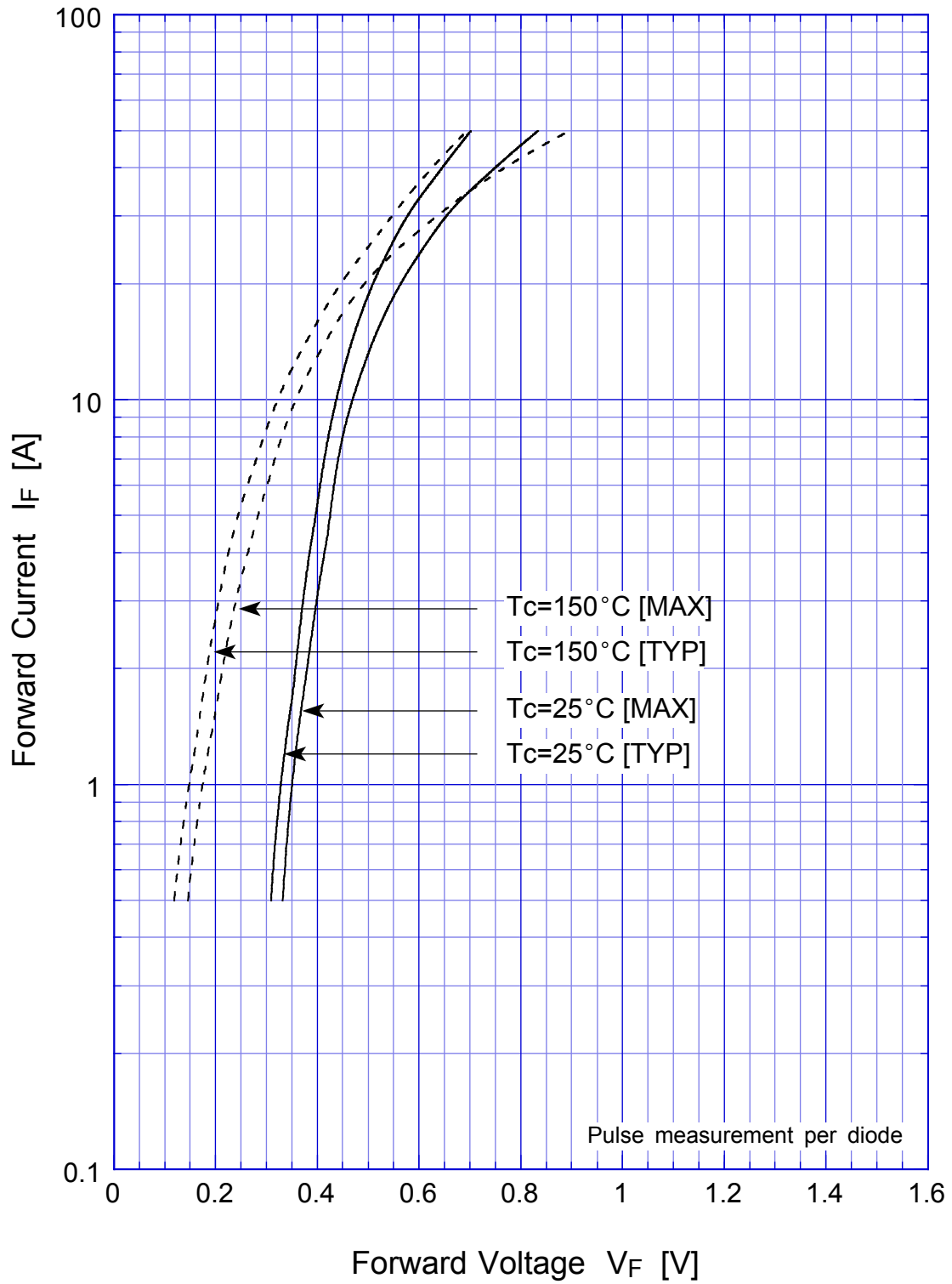

SF20SC3L Junction Capacitance

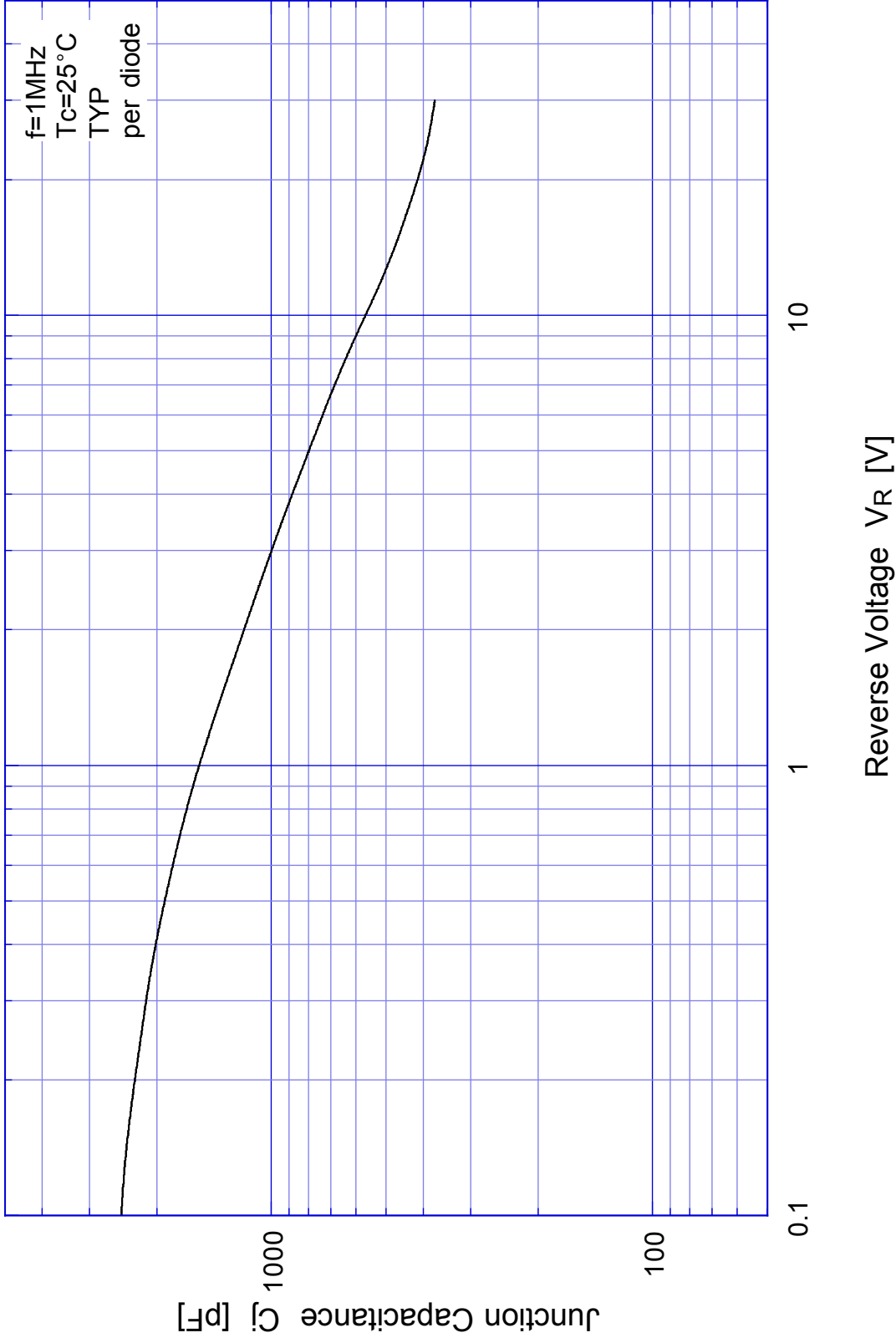

SF20SC3L Reverse Current

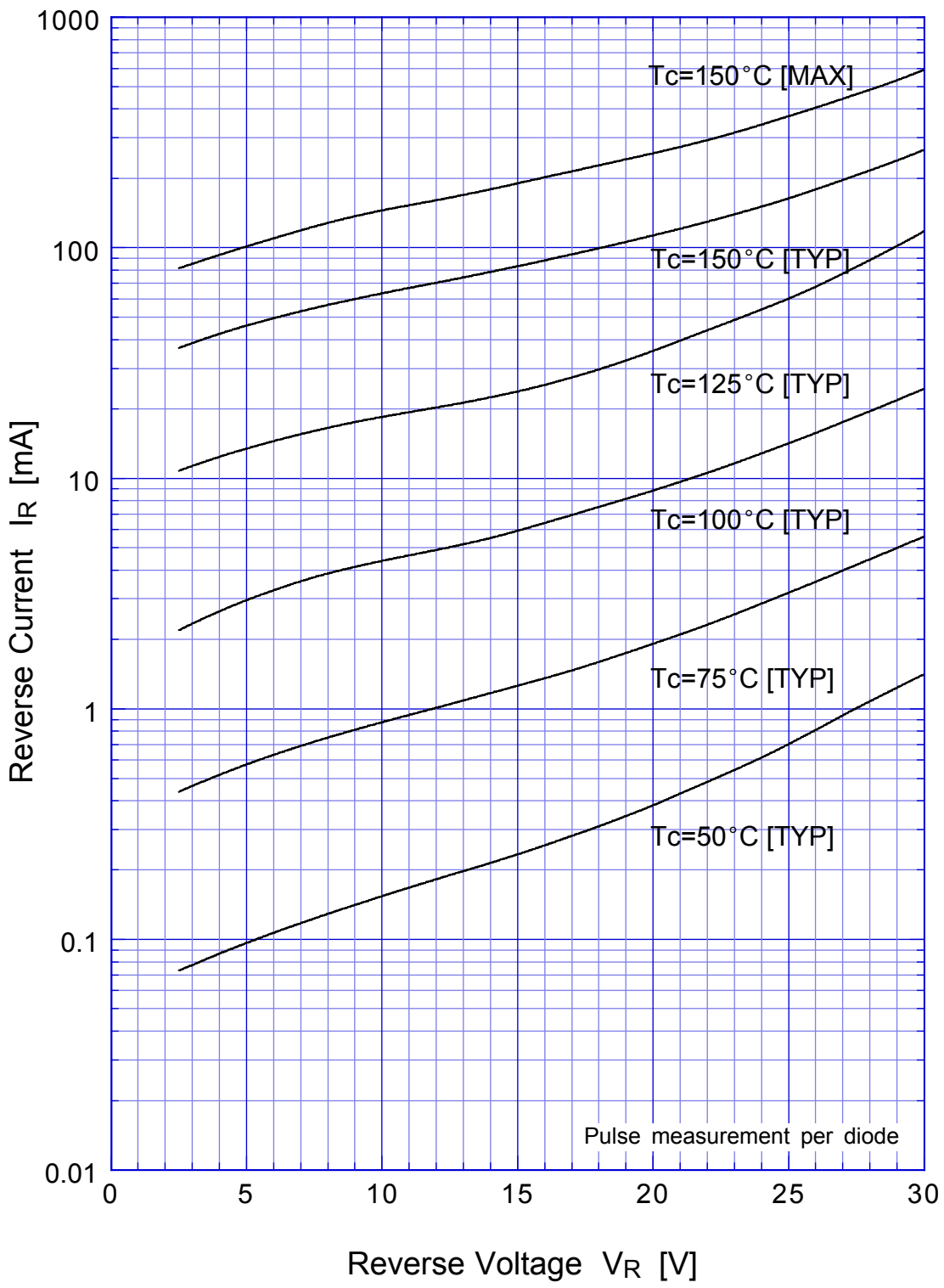

SF20SC3L Reverse Power Dissipation

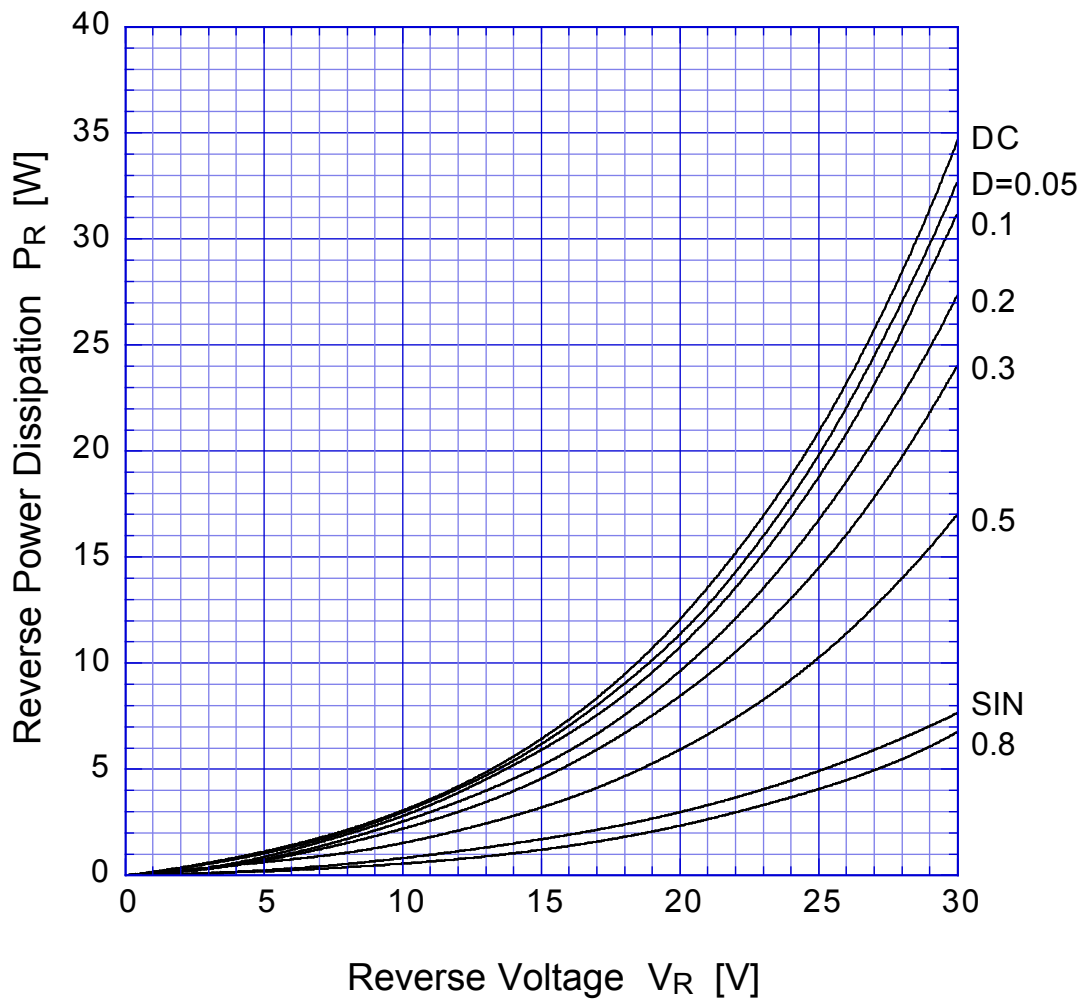

$T_j = T_{jmax}$

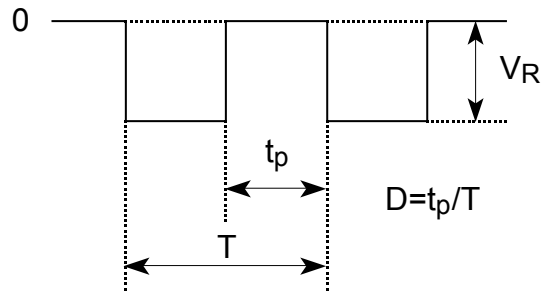

SF20SC3L Forward Power Dissipation

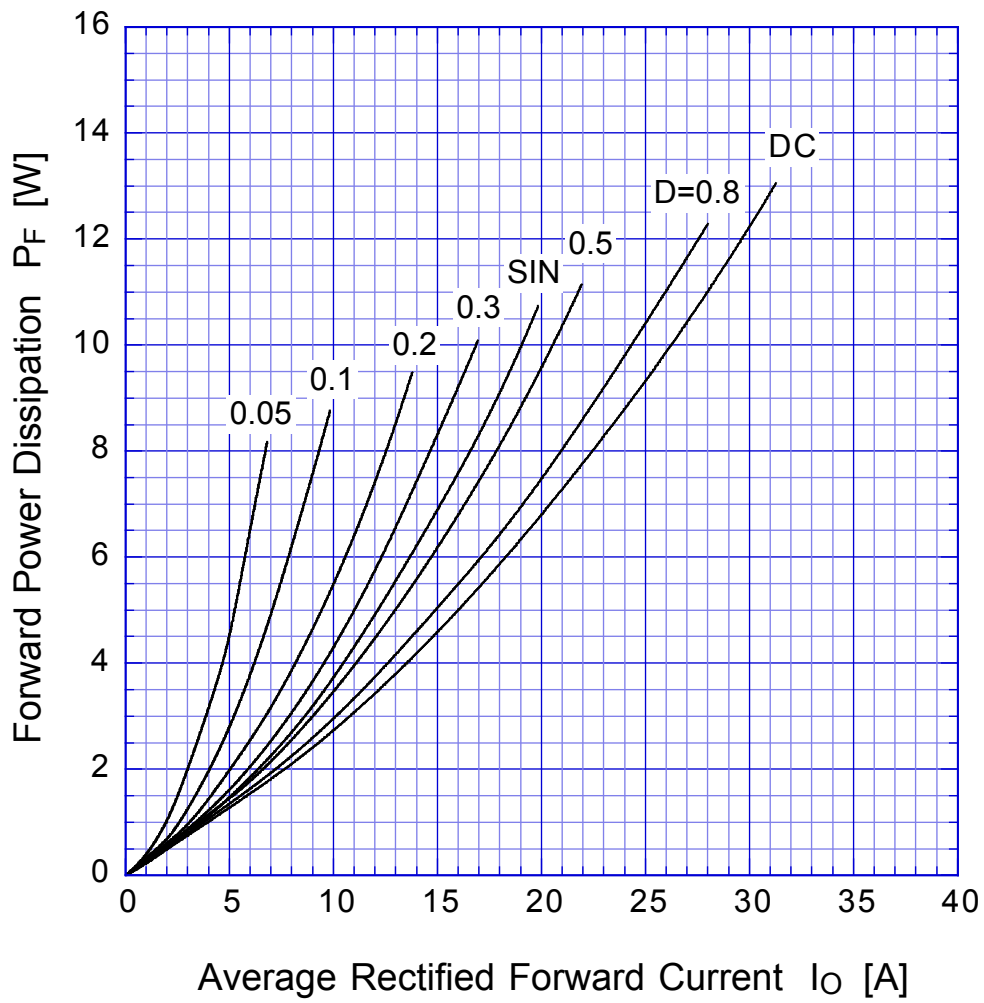

$T_j = T_{jmax}$

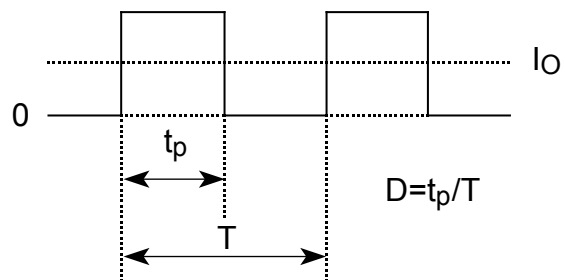

SF20SC3L

Derating Curve

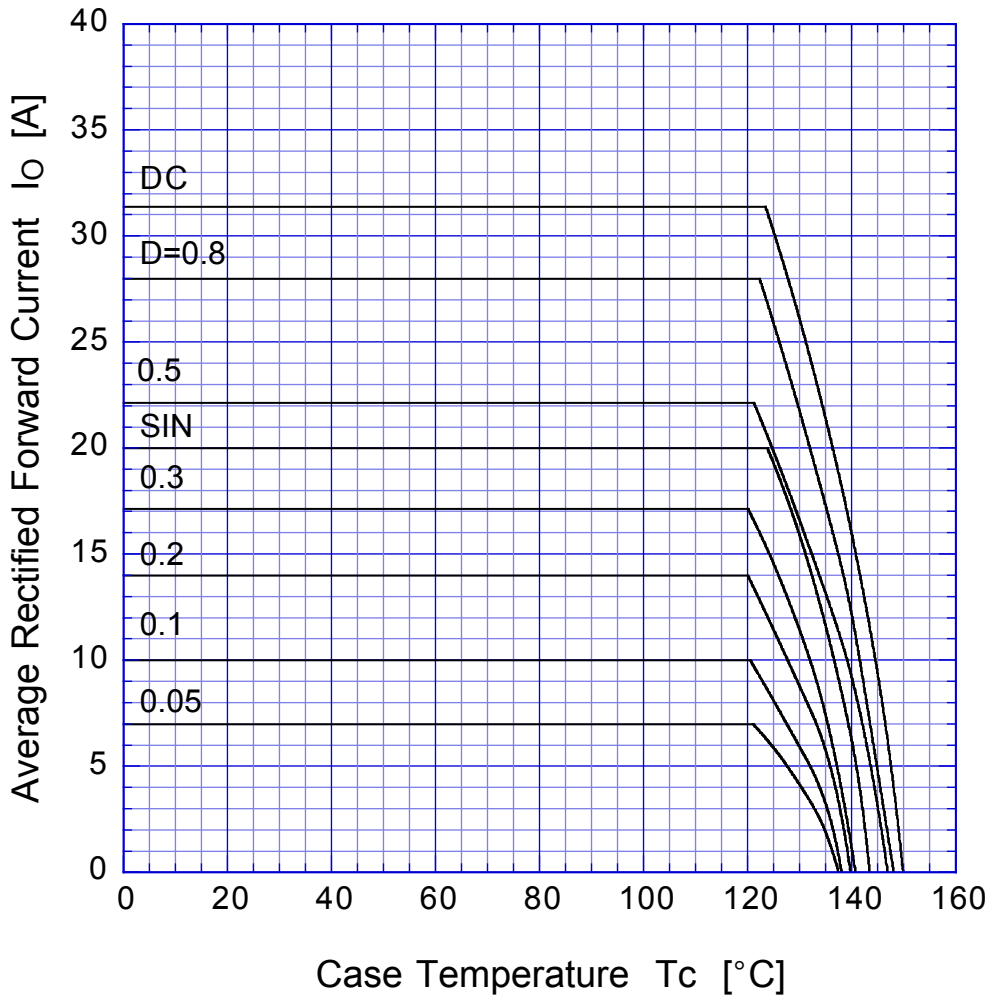

$$V_R = V_{RM}/2$$

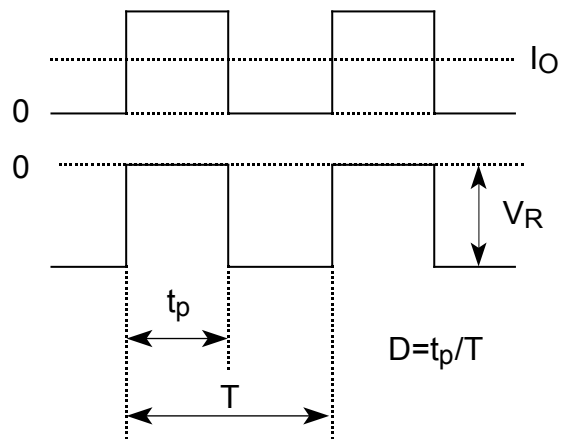

SF20SC3L Peak Surge Forward Capability

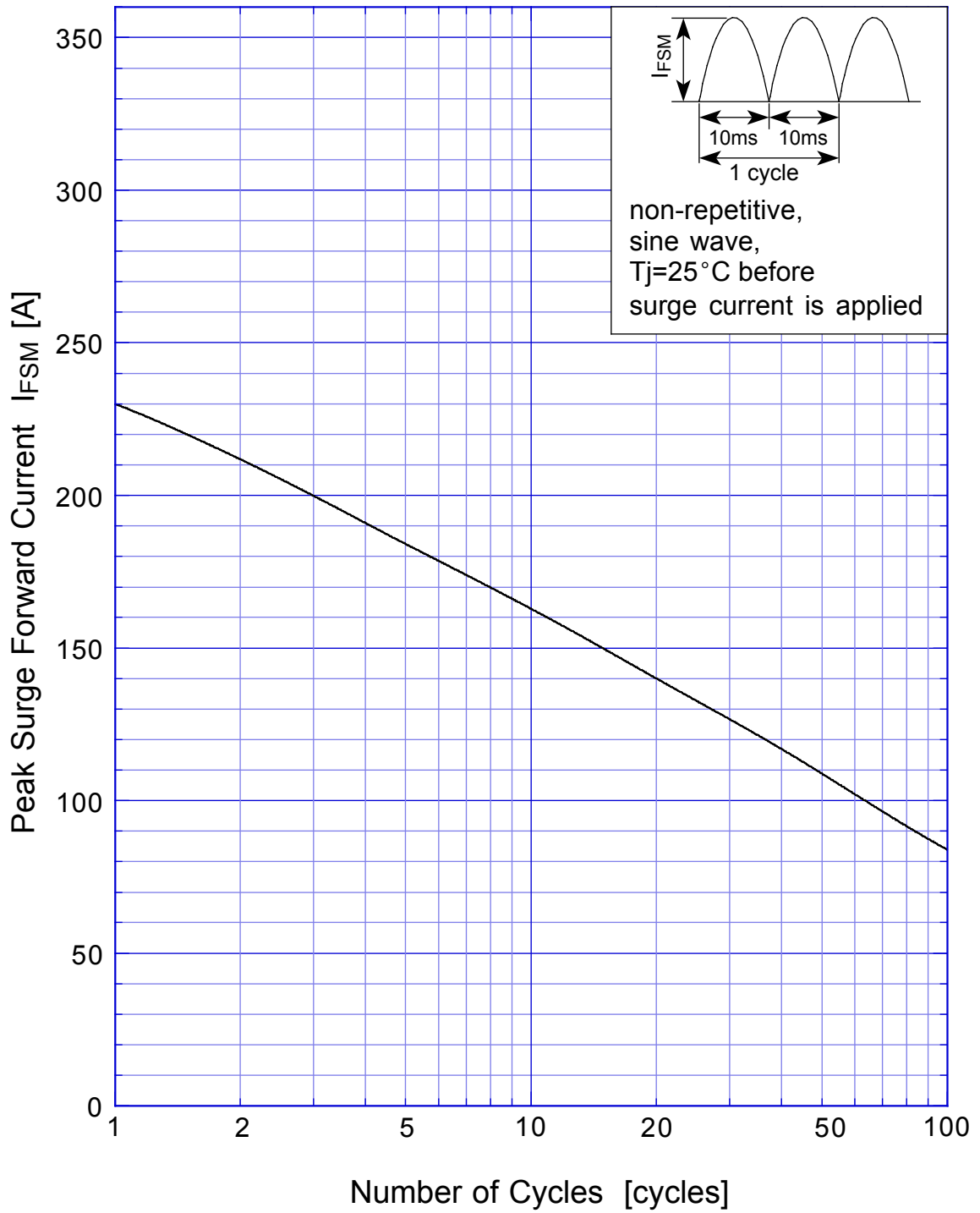

SBD Repetitive Surge Reverse Power Derating Curve



SBD

Repetitive Surge Reverse Power Capability

