

Unit in mm

Chopper, Inverter Application

- Repetitive Peak Off-State Voltage: $V_{DRM}=1300, 1600, 1800, 2500V$
- R.M.S. On-State Current: $I_T (RMS)=1050A$
- Peak Turn-Off Current: $I_{TGQM}=2000A$
- Critical Rate of Rise of On-State Current: $di/dt=300A/\mu s$
- Critical Rate of Rise of Off-State Voltage: $dv/dt=1000V/\mu s$

Maximum Ratings

CHARACTERISTIC		SYMBOL	RATINGS	UNIT
Repetitive Peak Off-State Voltage (Note 1)	SG2000R24	V_{DRM}	1300	V
	SG2000U24		1600	
	SG2000W24		1800	
	SG2000EX24		2500	
Repetitive Peak Reverse Voltage		V_{RRM}	16	V
Peak Turn-Off Current (Note 2)		I_{TGQM}	2000	A
R.M.S. On-State Current (Note 3)		$I_T (RMS)$	1050	A
Peak One Cycle Surge On-State Current (Non-Repetitive, 10ms-Width Half Sine Waveform)		I_{TSM}	14000	A
Critical Rate of Rise of On-State Current (Note 4)		di/dt	300	A/ μs
Peak Forward Gate Current		I_{FGM}	70	A
Average Forward Gate Power Dissipation		$P_{FG (AV)}$	14	W
Average Reverse Gate Power Dissipation		$P_{RG (AV)}$	120	W
R.M.S. Gate Current (Note 5)		$I_G (RMS)$	42	A
Peak Reverse Gate Voltage (at Static)		V_{RGM}	16	V
Operating Junction Temperature Range		T_j	-40 ~ 125	°C
Storage Temperature Range		T_{stg}	-40 ~ 150	°C
Mounting Force		—	19.6±2.0	kN

Note 1. $R_{GK}=10\Omega$

Note 2. $C_s=4\mu F, R_s=5\Omega, di_{GQ}/dt=40A/\mu s, I_{GQ}=450A, V_{DM}=V_{DRM}, T_j=125^\circ C, V_{Dsp}\leq 600V, L_s\leq 0.3\mu H$

Note 3. Half Sine Waveform, $T_r=80^\circ C$

Note 4. $V_D=1/2$ Rated, $I_G=30A$

Note 5. Ambient Temperature of coaxial gate-cathode lead=90°C

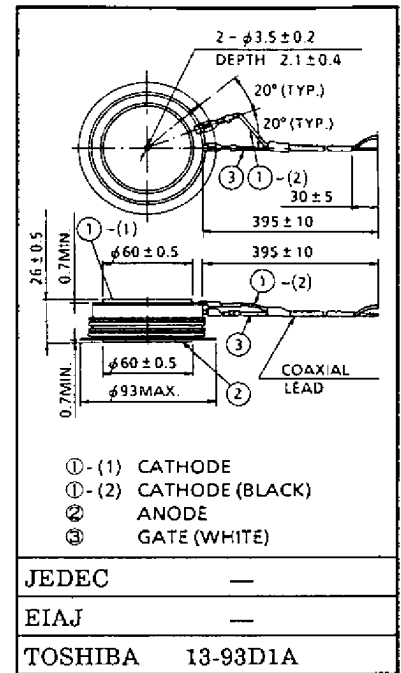

Weight : 800g

The information contained here is subject to change without notice.

The information contained herein is presented only as guide for the applications of our products. No responsibility is assumed by TOSHIBA for any infringements of patents or other rights of the third parties which may result from its use. No license is granted by implication or otherwise under any patent or patent rights of TOSHIBA or others. These TOSHIBA products are intended for usage in general electronic equipments (office equipment, communication equipment, measuring equipment, domestic electrification, etc.) Please make sure that you consult with us before you use these TOSHIBA products in equipments which require high quality and/or reliability, and in equipments which could have major impact to the welfare of human life (atomic energy control, spaceship, traffic signal, combustion control, all types of safety devices, etc.). TOSHIBA cannot accept liability to any damage which may occur in case these TOSHIBA products were used in the mentioned equipments without prior consultation with TOSHIBA.

Electrical Characteristics

CHARACTERISTIC	SYMBOL	TEST CONDITION	MIN.	TYP.	MX.	UNIT	
Repetitive Peak Off-State Current	I_{DRM}	$V_{DRM} = \text{Rated}$, $R_{GK} = -10\Omega$, $T_j = 125^\circ\text{C}$	–	–	50	mA	
Repetitive Peak Reverse Current	I_{RRM}	$V_{RRM} = \text{Rated}$, $T_j = 125^\circ\text{C}$	–	–	10	mA	
Repetitive Peak Reverse Gate Current	I_{RGM}	$V_{RGM} = \text{Rated}$, $T_j = 125^\circ\text{C}$	–	–	10	mA	
Peak On-State Voltage	V_{TM}	$I_{TM} = 2000\text{A}$, $T_j = 125^\circ\text{C}$	–	–	2.4	V	
Gate Trigger Current	V_{GT}	$V_D = 24\text{V}$, $R_L = 0.1\Omega$	$T_j = -40^\circ\text{C}$	–	–	1.5	V
			$T_j = 25^\circ\text{C}$	–	–	1.0	
Gate Trigger Voltage	I_{GT}		$T_j = -40^\circ\text{C}$	–	–	6.0	A
			$T_j = 25^\circ\text{C}$	–	–	2.5	
Turn-On Delay Time	t_d	$V_D = 1/2 \text{ Rated}$, $di/dt = 300\text{A}/\mu\text{s}$, $I_{TM} = 2000\text{A}$, $I_G = 30\text{A}$ ($t_r = 1\mu\text{s}$), $T_j = 25^\circ\text{C}$	–	–	2.0	μs	
Turn-On Time	t_{gt}		–	–	10	μs	
Critical Rate of Rise of Off-State Voltage	dv/dt	$V_{DRM} = 2/3 \text{ Rated}$, $T_j = 125^\circ\text{C}$, $V_{GK} = -2\text{V}$, Exponential Rise	1000	–	–	$\text{V}/\mu\text{s}$	
Storage Time	t_s	$I_T = 2000\text{A}$, $V_D = 1/2 \text{ Rated}$, $V_{DM} = V_{DRM}$, $C_S = 4\mu\text{F}$, $di_{GQ}/dt = 40\text{A}/\mu\text{s}$, $T_j = 125^\circ\text{C}$, $L_S \leq 0.3\mu\text{H}$	–	–	20	μs	
Gate Turn-Off Time	t_{gq}		–	–	23	μs	
Gate Turn-Off Current	I_{GQ}		–	–	60	μs	
Tail Time	t_{tail}		–	450	–	A	
Thermal Resistance (Junction to Fin)	$R_{th(j-f)}$		DC	–	–	0.02	$^\circ\text{C}/\text{W}$

