

# 3-terminal Dropper Type Regulator SI-3003S

## Features

- 3-terminal IC regulator with 0.8A output current
- Voltage accuracy of  $\pm 2\%$
- Low Dropout voltage  $\leq 0.5V$  at  $I_O \leq 0.5A$ ,  $\leq 1V$  at  $I_O \leq 0.8A$
- Built-in constant current type overcurrent, overvoltage and thermal protection circuits
- TO-220 equivalent full-mold package

## Absolute Maximum Ratings

( $T_a = 25^\circ C$ )

Parameter	Symbol	Ratings	Unit	Conditions
DC input voltage	$V_{IN}$	35	V	
Output current	$I_O$	0.8 *2	A	
Power Dissipation	$P_{D1}$	22	W	With infinite heatsink
	$P_{D2}$	1.8	W	Stand-alone without heatsink
Junction temperature	$T_J$	-40 to +150	$^\circ C$	
Operating temperature	$T_{OP}$	-40 to +100	$^\circ C$	
Storage temperature	$T_{stg}$	-40 to +150	$^\circ C$	
Junction to case thermal resistance	$\theta_{j-c}$	5.5	$^\circ C/W$	
Junction to ambient-air thermal resistance	$\theta_{j-a}$	66.7	$^\circ C/W$	Stand-alone without heatsink

## External Dimensions (unit: mm)

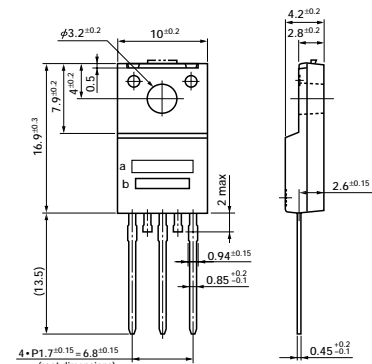

Terminal connections  
 1.  $V_{IN}$   
 2. (NC)  
 3. GND  
 4. (NC)  
 5.  $V_O$   
 a: Type No.  
 b: Lot No.  
 (Forming No. 1115)

## Electrical Characteristics

( $T_J = 25^\circ C$ ,  $V_{IN} = 14V$ ,  $I_O = 0.5A$  unless otherwise specified)

Parameter	Symbol	Ratings			Unit	Conditions
		min	typ	max		
Input voltage	$V_{IN}$	6 *2		30 *1	V	
Output voltage	$V_O$	4.90	5.00	5.10	V	
Dropout voltage	$V_{DIF}$			0.5	V	$I_O \leq 0.5A$
				1.0	V	$I_O \leq 0.8A$
Line regulation	$\Delta V_{O LINE}$			30	mV	$V_{IN} = 8$ to $16V$
Load regulation	$\Delta V_{O LOAD}$			100	mV	$I_O = 0$ to $0.5A$
Ripple rejection	$R_{REJ}$		54		dB	$f = 100$ to $120Hz$
Quiescent circuit current	$I_q$		3	10	mA	$I_O = 0A$
Overcurrent protection starting current	$I_{S1}$	0.9 *3			A	

### Notes:

- \*1. Since  $P_{D(max)} = (V_{IN} - V_O) \cdot I_O = 22(W)$ ,  $V_{IN(max)}$  and  $I_{O(max)}$  may be limited depending on operating conditions. Refer to the  $T_a - P_D$  curve to compute the corresponding values.
- \*2. Refer to the dropout voltage.
- \*3.  $I_{S1}$  rating shall be the point at which the output voltage  $V_O$  ( $V_{IN} = 14V$ ,  $I_O = 0.5A$ ) drops to -5%.

## Equivalent Circuit Diagram

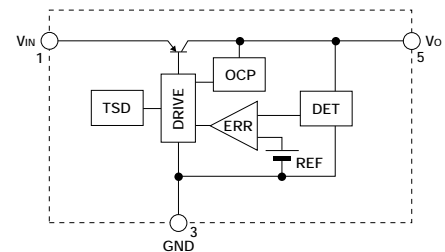

## Standard Circuit Diagram

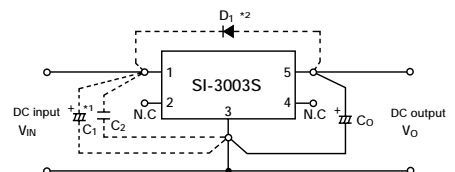

- $C_O$ : Output capacitor (47 to 100 $\mu F$ , 50V)
- \*1  $C_1, C_2$ : Anti-oscillation capacitors ( $C_1$ : approx. 47 $\mu F$ ,  $C_2$ : approx. 0.33 $\mu F$ ). These are required for inductive input lines or long wiring. Tantalum capacitors are recommended for  $C_1$  and  $C_O$ , especially at low temperatures.
- \*2  $D_1$ : Protection diode. Required as protection against reverse biasing between input and output.  
(Recommended diode: Sanken EU2Z.)

■  $I_O$  vs  $V_{DIF}$  Characteristics

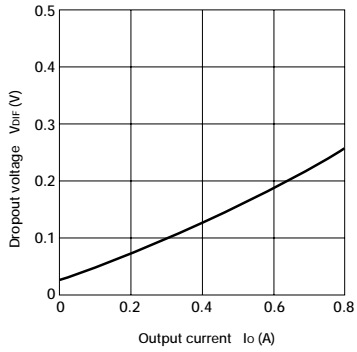

■ Line Regulation

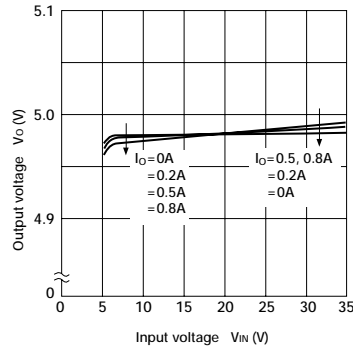

■ Load Regulation

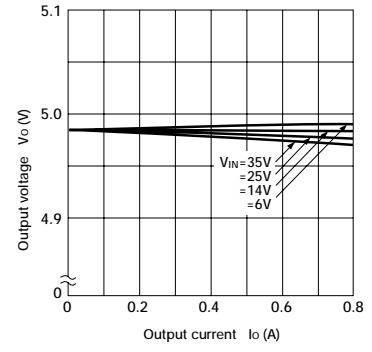

■ Output Voltage Temperature Characteristics

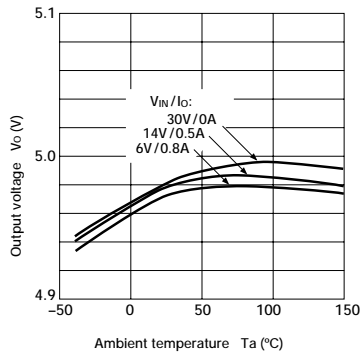

■ Rise Characteristics

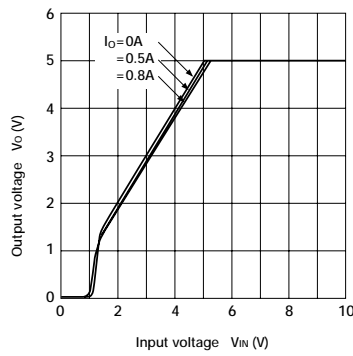

■ Circuit Current

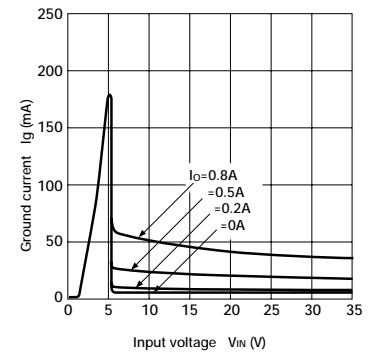

■ Overcurrent Protection Characteristics

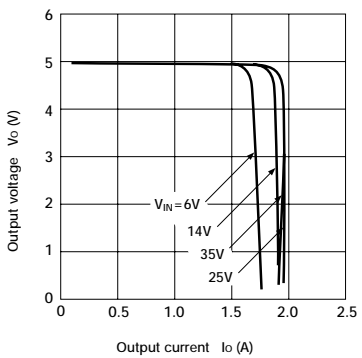

■ Thermal Protection Characteristics

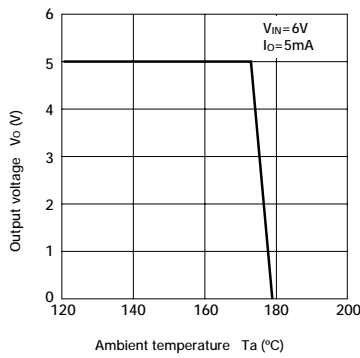

■  $T_a$ — $P_D$  Characteristics

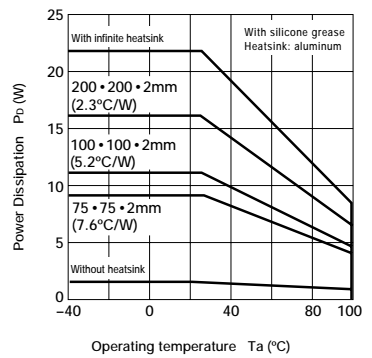

**Note on Thermal Protection Characteristics:**  
The thermal protection circuit is intended for protection against heat during instantaneous short-circuiting. Its operation, including reliability, is not guaranteed for short-circuiting over an extended period of time.