

SLA3005M/3006M

4-Output, Low Dropout Voltage Dropper Type for USB Hub

■Features

- 4 regulators combined in one package
- Insulated single inline package
- Output (5V/0.5A×4 output)
- Low dropout voltage: $V_{DIF} \leq 0.5V$ (at $I_o = 0.5A$)
- Output-independent ON/OFF control terminal compatible with LS-TTL (Active High)
- Output-independent overcurrent and thermal protection circuits built in
- Open collector flag-output terminals built in to output OCP operation to each output terminal (Active Low)
- SLA3005M for V_o shutdown after OCP operation and SLA3006M for continuous OCP operation
- Built-in anti-malfunction delay circuit whose time can be set with an external capacitor

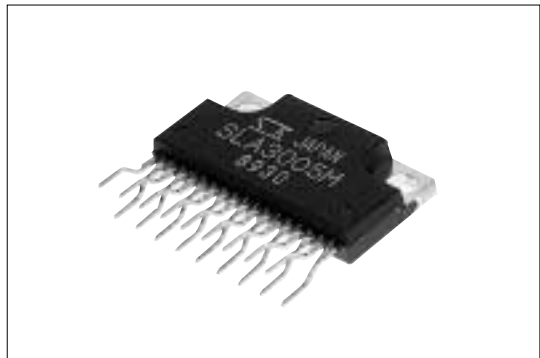

■Applications

- USB hub power supplies
- Electronic equipment

■Absolute Maximum Ratings

($T_a = 25^\circ C$)

Parameter	Symbol	Ratings	Unit
DC Input Voltage	V_{IN}	20	V
Voltage of Output Control Terminal	V_c	V_{IN}	V
DC Output Current	I_o	0.5	A
Power Dissipation	P_{D1}	30(With infinite heatsink)	W
	P_{D2}	3.36(Without heatsink, stand-alone operation)	W
Junction Temperature	T_j	-30 to +125	$^\circ C$
Ambient Operating Temperature	T_{OP}	-30 to +100	$^\circ C$
Storage Temperature	T_{stg}	-30 to +125	$^\circ C$
Thermal Resistance (junction-to-case)	$R_{t(j-c)}$	9.0	$^\circ C/W$
Thermal Resistance (junction-to-ambient air)	$R_{th(j-a)}$	29.8(Without heatsink, stand-alone operation)	$^\circ C/W$

■Recommended Operating Conditions

Parameter	Symbol	Ratings	Unit
DC Input Voltage Range	V_{IN}	5.5 to 10	V
Output Current Range	I_o	0 to 0.5	A
Operating Junction Temperature Range	T_{jop}	-20 to +100	$^\circ C$
Ambient Operating Temperature Range	T_{aop}	-20 to +85	$^\circ C$

Electrical Characteristics

(T_a=25°C unless otherwise specified)

Parameter	Symbol	Ratings						Unit	
		SLA3005M			SLA3006M				
		min.	typ.	max.	min.	typ.	max.		
Output Voltage	V _o	4.85	5.00	5.15	4.85	5.00	5.15	V	
	Conditions	V _{IN} =7V, I _o =0.1A			V _{IN} =7V, I _o =0.1A				
Dropout Voltage	V _{DIF}			0.5			0.5	V	
	Conditions	I _o ≤0.5A			I _o ≤0.5A				
Line Regulation	ΔV _{OLINE}			30			30	mV	
	Conditions	V _{IN} =6 to 15V, I _o =0.1A			V _{IN} =6 to 15V, I _o =0.1A				
Load Regulation	ΔV _{LOAD}			50			50	mV	
	Conditions	V _{IN} =7V, I _o =0 to 0.5A			V _{IN} =7V, I _o =0 to 0.5A				
Temperature Coefficient of Output Voltage	ΔV _o /ΔT _a		±0.5			±0.5		mV/°C	
	Conditions	V _{IN} =7V, I _o =5mA, T _j =-10 to 100°C			V _{IN} =7V, I _o =5mA, T _j =-10 to 100°C				
Quiescent Circuit Current* ³	I _q			20			20	mA	
	Conditions	V _{IN} =7V, I _o =0A			V _{IN} =7V, I _o =0A				
Quiescent Circuit Current (Output OFF)* ³	I _{q(off)}			0.5			0.5	mA	
	Conditions	V _{IN} =7V, V _{c1} to 4=0V			V _{IN} =7V, V _{c1} to 4=0V				
Overcurrent Protection Starting Current* ¹	I _{s1}	0.55		0.65	0.75		0.96	A	
	Conditions	V _{IN} =7V			V _{IN} =7V				
V _c Terminal ²	Control Voltage (Output ON)	V _c IH	2.0		2.0			V	
	Control Voltage (Output OFF)	V _c IL			0.7		0.7		
	Control Current (Output ON)	I _c IH			50			50	μA
		Conditions	V _c =2.7V			V _c =2.7V			
	Control Current (Output OFF)	I _c IL			-100			-100	μA
Conditions		V _c =0V			V _c =0V				
OCP Detection Voltage Level		V _{oth}	3.7	4.0	4.3	3.7	4.0	4.3	V
Delay Threshold Voltage		V _{DLYth}	2.1	2.3	2.5	2.1	2.3	2.5	V
Delay Terminal Runoff Current		I _{DLY}	35	50	65	35	50	65	μA
Flag Output Terminal	Before OCP Detection	V _{FLGh}	V _{IN} -0.4			V _{IN} -0.4			V
		Conditions	R _{FLG} connected between FLG and V _{IN}			R _{FLG} connected between FLG and V _{IN}			
	After OCP Detection	V _{FLGi}			0.5			0.5	V
		Conditions	I _{FLG} =1mA			I _{FLG} =1mA			

*1 I_{s1} is specified at -5(%) drop point of output voltage V_o on the condition that V_{IN} = 7V, I_o = 0.1A.

*2 Output is ON even when output control terminal V_c is open. Each input level is equivalent to LS-TTL. Therefore, it may be directly driven by an LS-TTL circuit.

*3 Total of four circuits

*4 The FLG output latched by delay DLY after OCP detection. (SLA3005M shuts down the output voltage simultaneously at latching.) Set the V_{IN} or V_c to low to reset latching. Leave a time lag of C_d × 600s or more before restart.

■Outline Drawing

(unit:mm)

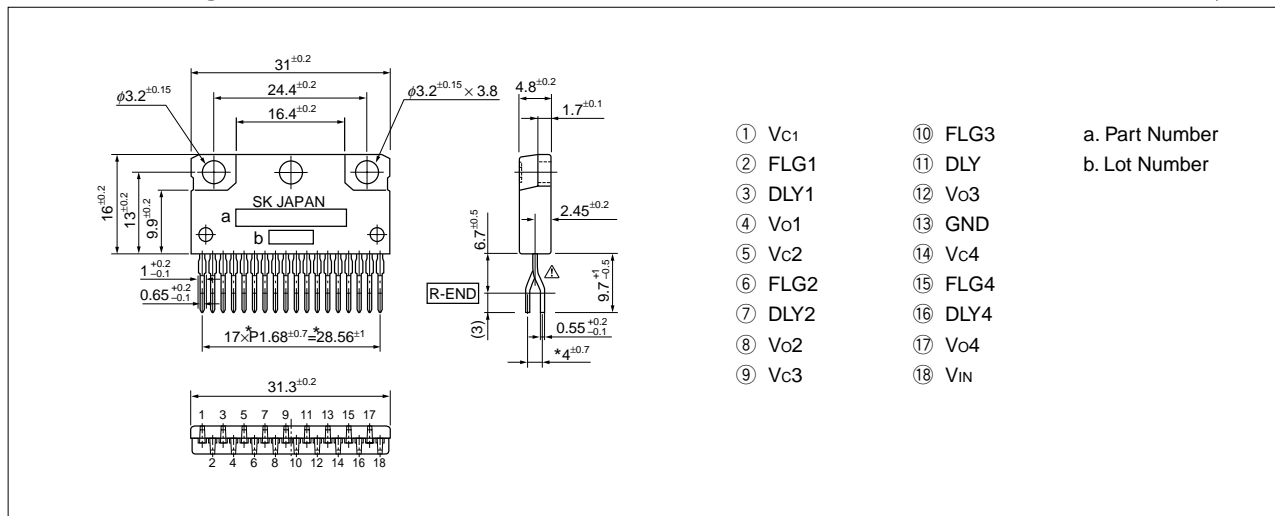

■Block Diagram

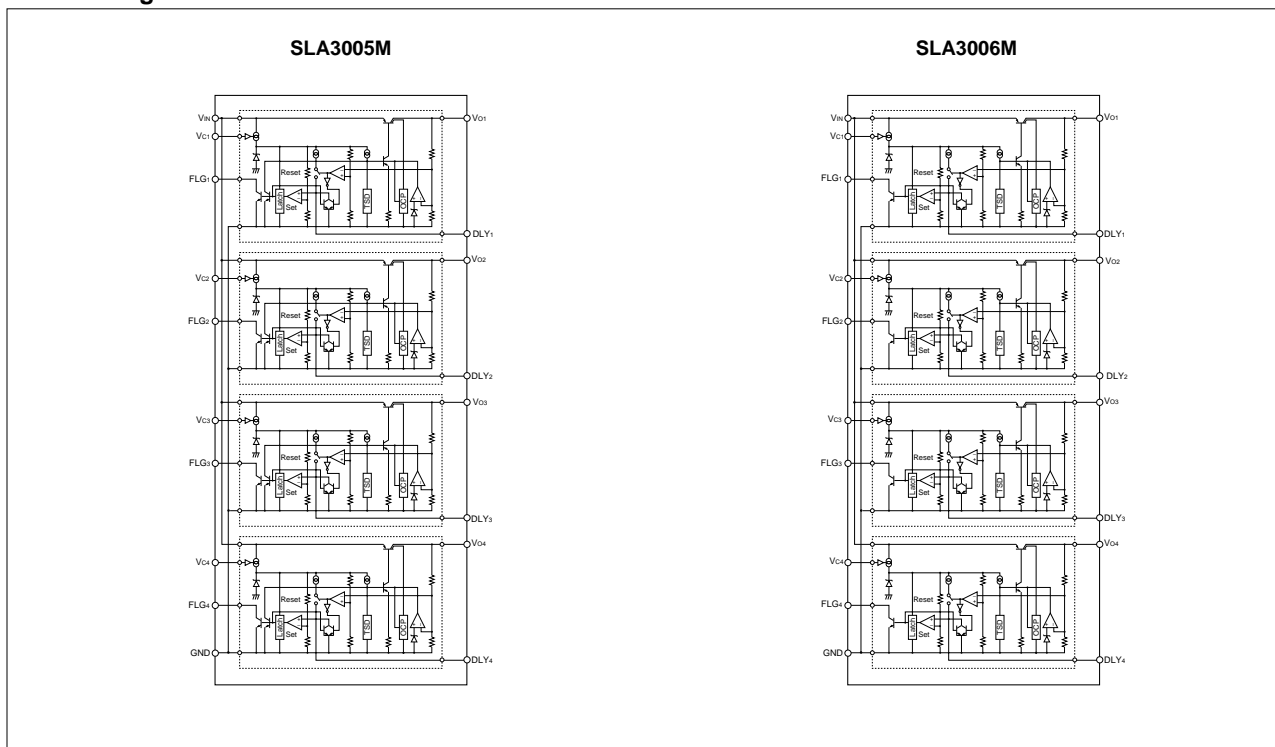

Standard External Circuit

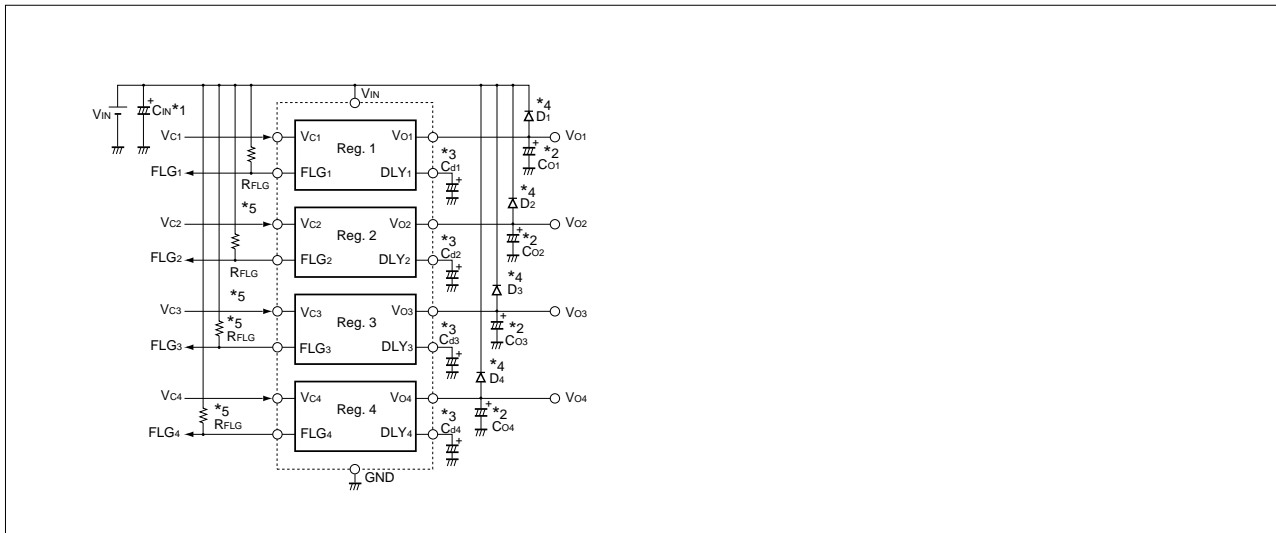

- *1 C_{IN} : Input capacitor (Approx. 47 μ F)
This capacitor is required if the input line is inductive and in the case of long wiring.
- *2 C_o : Output capacitor (47 to 220 μ F)
- *3 C_d : Delay setting capacitor (0.1 μ F or more)
Use C_d to set the delay time (t_{DLY}) from when a low V_o level due to OCP operation is detected until a flag signal is output.
This prevents a rush current from causing malfunction.
Approximate calculation: $t_{DLY} \approx (C_d \times V_{DLYth}) / I_{DLY}$ [sec]
When using soft start on V_{IN} or if C_{IN} has a large capacitance, set t_{DLY} long enough for the output voltage to rise sufficiently.
Be sure to connect C_d and do not use it for other applications, such as short circuiting C_d .
- *4 D_1 to D_4 : Reverse biasing protection diode
This diode is required for protection against reverse biasing of the input and output.
- *5 R_{FLG} : Set this to limit the inflow current into the FLG terminal to 1mA or less.

Ta-Pd Characteristics

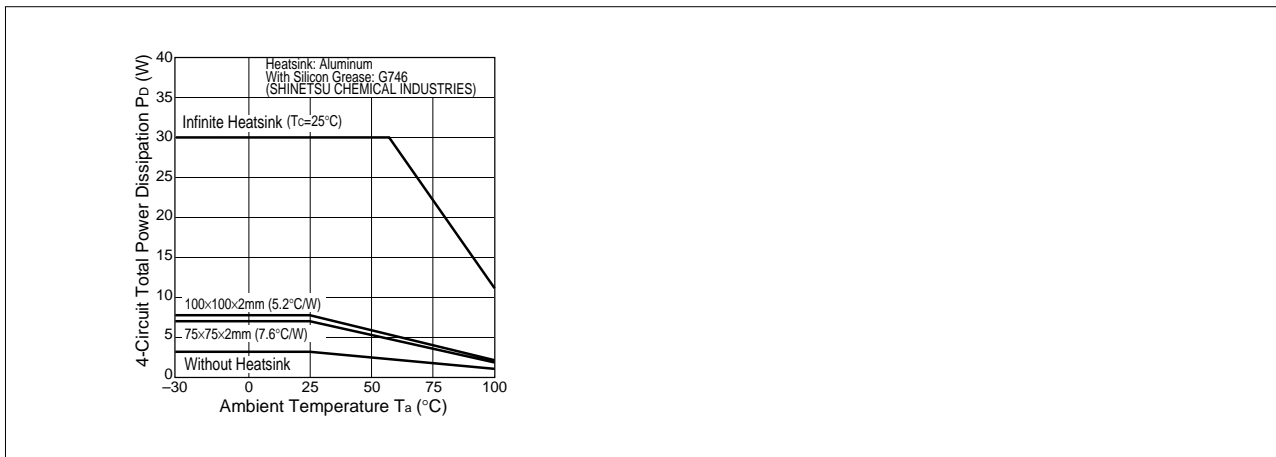

Calculating the internal dissipation

P_D is calculated as follows:

$$P_D = [I_{O1} \cdot (V_{IN} - V_{O1})] + [I_{O2} \cdot (V_{IN} - V_{O2})] + [I_{O3} \cdot (V_{IN} - V_{O3})] + [I_{O4} \cdot (V_{IN} - V_{O4})] + V_{IN} \cdot I_G$$

Estimating Tj by heat measurement

1. Measuring position: At the root of pin 13
2. Add the thermal resistance " θ_{j-L} " between the junction and pin 13 and the P_d product of each channel to the measured temperature.
 θ_{j-L} is as follows : θ_{j-L1} :8°C/W, θ_{j-L2} :7°C/W, θ_{j-L3} :5°C/W, θ_{j-L4} :8°C/W
The calculation formula is as follows : $T_j = \theta_{j-L1} \cdot P_{d1} + \theta_{j-L2} \cdot P_{d2} + \theta_{j-L3} \cdot P_{d3} + \theta_{j-L4} \cdot P_{d4} + T_{13pin}$

■Typical Characteristics SLA3005M

($T_a=25^\circ\text{C}$)

