

Stepper Motor Driver SLA4708M

Features

- High output breakdown voltage of 50V
- Affluent output current of 1.5A
- Built-in overcurrent, overvoltage and thermal protection circuits
- Low standby current of 50μA

Absolute Maximum Ratings

(Ta = 25°C)

Parameter	Symbol	Ratings	Unit	Conditions
Power supply voltage	V _S	35	V	
Breakdown voltage	V _O	50	V	
Input voltage	V _{IN}	-0.3 to +7	V	
Output current	I _{O, AVE}	1.5	A	
Diagnostic output sink current	I _{DIAG}	10	mA	
Diagnostic output withstand voltage	I _{DIAG, H}	7	V	
Operating temperature	T _{op}	-40 to +85	°C	
Storage temperature	T _{stg}	-40 to +150	°C	
Power Dissipation	P _D	3.5 (Ta=25°C)	W	Without heatsink

Electrical Characteristics

(V_S = 12V, Ta = 25°C)

Parameter	Symbol	Ratings			Unit	Conditions
		min	typ	max		
Input voltage (I _{A/A} , I _{B/B} standby)	V _{IL}			0.8	V	
	V _{IH}	2.4			V	
Input current	I _{IL}			-0.8	mA	V _{IN} = 0.4V
	I _{IH}			50	μA	V _{IN} = 2.4V
Output saturation voltage	V _{O, STA}			1.3	V	I _O = 1A, Ta = 25°C
	V _{O, STA}			1.5	V	I _O = 1.5A, Ta = 25°C
Output leak current	I _{O, LEAK}			100	μA	V _O = 16V
Overcurrent detection	I _{SD}	1.8			A	
Overvoltage detection	V _{SD}	27.5			V	
Saturation voltage of diagnostic output	V _{DIAG, L}			0.3	V	I _{DIAG} = 5mA
Standby current	I _{STB}		50		μA	V _S = 12V

External Dimensions (unit: mm)

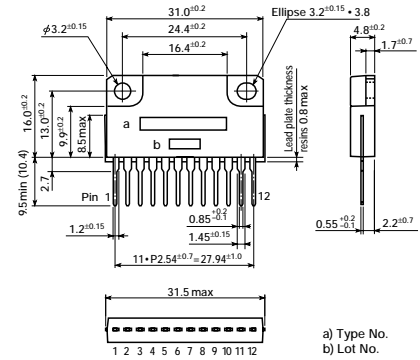

Standard Circuit Diagram

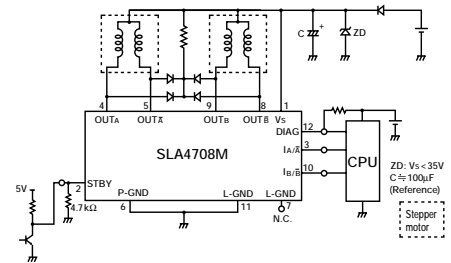

■ Power Supply Current Characteristics

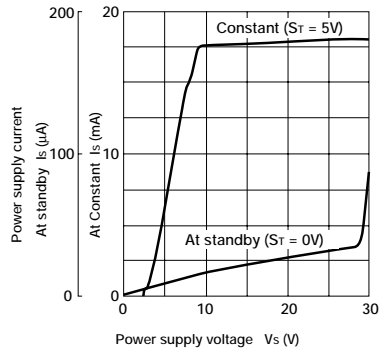

■ Overvoltage Protection Characteristics

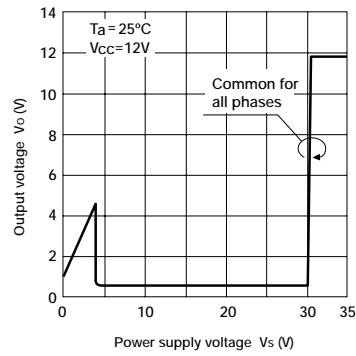

■ Saturation Voltage of Output Transistor Characteristics

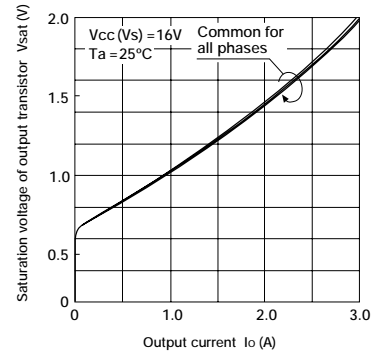

■ Thermal Protection Characteristics

