



SLP-3118B-51-T1

ø3.1mm yellow-green contact type taping lamp

Features

- GaP yellow green LED
- 3.1mmø, round top type lamp
- Diffused green resin package type
- High luminous intensity, high reliability and long life
- SLP-3118B-51 taping type for an automatic use
- The insertion which made it stick to PCB is possible
- Application : for the general public welfare

Absolute Maximum Ratings at Ta=25°C (as per JIS C 7032)

Parameter	Symbol	Rating	Unit
Forward Current *1	I _F	25	mA
Pulse Forward Current *2	I _{FP}	100	mA
Reverse Voltage	V _R	3	V
Power Dissipation	P _D	70	mW
Operating Temperature	T _{opr}	-25 to +80	°C
Storage Temperature	T _{stg}	-30 to +85	°C
Soldering Temperature *3	T _{sol}	260	°C

*1 See forward current derating

*2 Pulse width = Max. 10ms Duty ratio = Max. 1 / 10

*3 Max. 5sec., Lead soldering condition : Min. 1.6mm from case (used 1.6mmt's PCB)

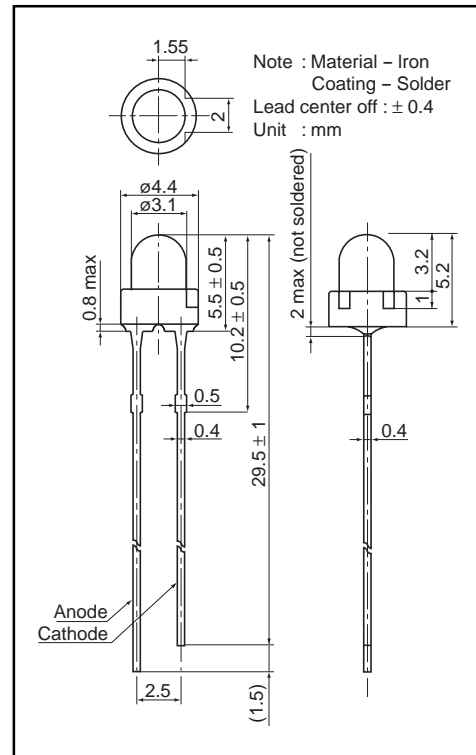

Electrical / Optical Characteristics at Ta=25°C

Parameter	Symbol	Conditions	Min	Typ	Max	Unit
Forward Voltage	V _F	I _F = 20mA	1.7	2.1	2.8	V
Reverse Current	I _R	V _R = 3V	-	-	10	μA
Luminous Intensity *4	I _V	I _F = 20mA	13	30	-	mcd
Peak Wave length	λ _P	I _F = 20mA	-	567	-	nm
Line Half Width	Δλ	I _F = 20mA	-	25	-	nm
Capacitance	C _O	V _O = 0 • F = 1MHz	-	50	-	pF
Response Time	t	-	-	250	-	ns

*4 Luminous Intensity is measured by J-16 (SONY TEKTRONIX) of which our office possess.

Typical Characteristics



These shows the electrical and optical characteristics of this products, and not assure this dispersive contents.

Forward Current vs. Forward Voltage

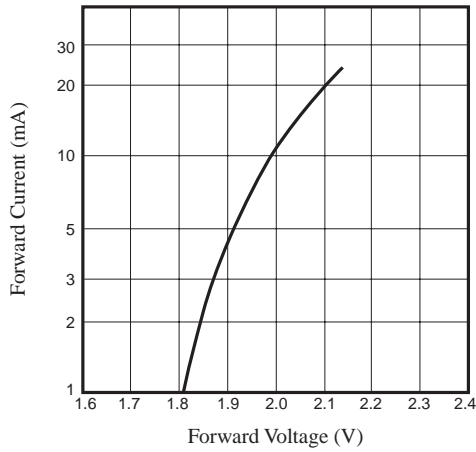

Intensity vs. Temperature (I_F : constant)

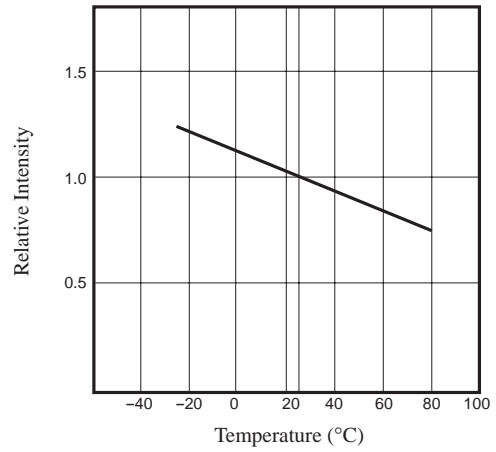

Intensity vs. Current

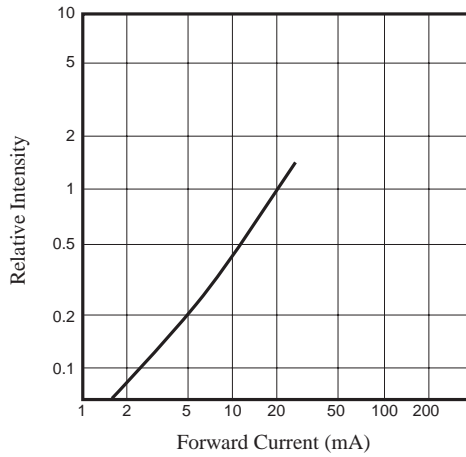

Spectrum

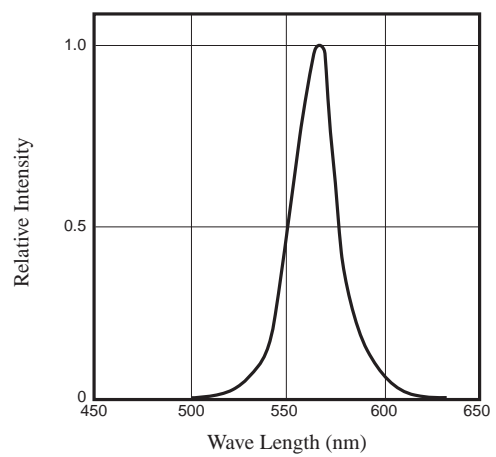

Forward Current Derating (Abusolute Maximum Rating)

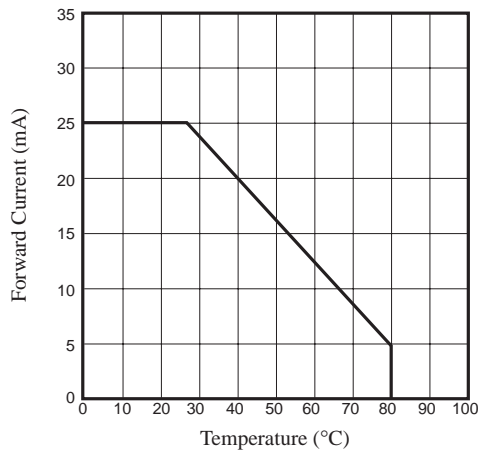

Directivity

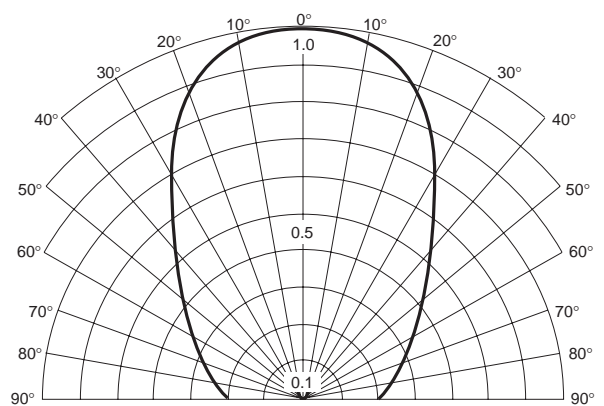

SLP-3118B-51-T1

1. General Description

These items are applied to taping type LED lamps for automatic use.

2. Taping Specification

Appearance and dimensions. (Refer to the supplementary drawing)

3. Notes

- (1) The polarity of LED lamp should be regularly oriented to one direction.
- (2) Sequential cracks in a taped unit shall be 3 pcs. max.

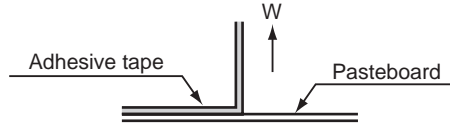

(3) Peeling

Adhesive strength of tape peeling in the vertical direction against the taped surface should be more than 300g. (See below)

(4) Tape conjunction method

① In the case of Tape pasteboard cutting

- Scotch tape is applied to connect or fix between tapes from the back side of the pasteboard.

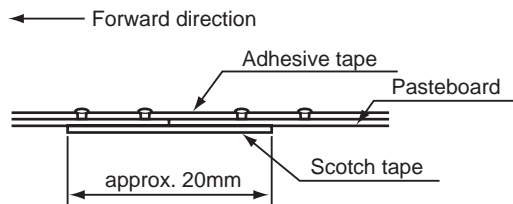

- Max. thickness of the tape should be less than 1.1mm.

② How to fix disconnected tape

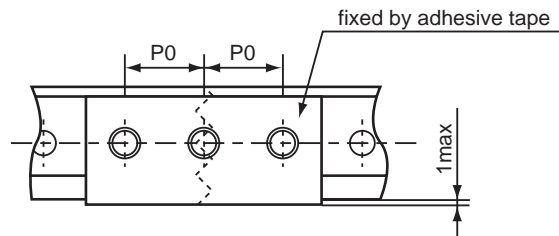

- Methode by adhesive tape : Stick over fixing each edge.

Note : Taping pitch (P0) should be placed properly. In the case of applying sticking way, the location is to be voluntary.

4. Packaging

- (1) The quantity is indicated on a packing case.
- (2) Packaging appearance and dimensions. (See right)

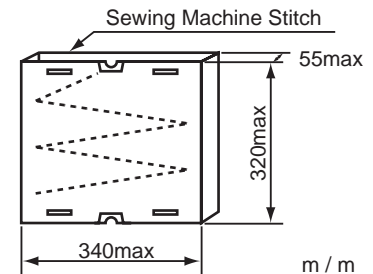

- ① Winding path will be employed as a packing method.
- ② When LED lamps are taken out of a packing case, follow the LED polarity configuration. (See below)
- ③ Packaging display

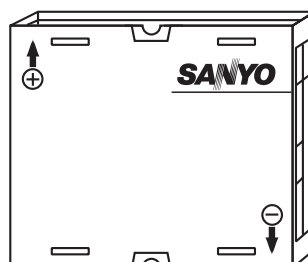

▲ PRECAUTIONS

< Automatic stick inserting, straight taping type >

- (1) Bending a lead should avoid not to cause chip deterioration or so. When bending is necessary, care must be taken considering the following points :
 - ① Bending a lead must be done before soldering.
 - ② A lead must be bent at intervals of 1.6mm from the edge of the resin part.
 - ③ Do not bend the same portion of lead more than twice.
- (2) Setting a product by a tool such as holder should avoid. When necessary, no stress should be applied to the resin part and lead by sufficient considerations on dimension tolerance, thermal expansion, thermal contraction of holder, product and circuit board.
- (3) The hole pitch of a circuit board must fit to its lead pitch.
- (4) When soldering, care must be taken considering the following points :
 - ① Do not heat a product under any stress (ex. : twist) to leads.
 - ② Do not heat (by soldering, for example) a product in the states of being forced to the resin part.
- (5) Do not use the flux containing chlorine (max. 0.2wt%) which may cause corrosion of lead and washing is preferable. When washing is necessary, avoid washing the whole product and wash only the needed part under the following conditions.
 - Chemicals : Methyl alchole.
 - Temperature : 45°C max.
 - Time : 30sec. max.

Note :Recommendatory conditions of automatic insertion and reflow (adhesive hardening process) taping lamp is automatically inserted and the chip portion is attached to the back side. When using taping lamp in the process through reflow furnace, follow the initial conditions in the new process to prevent gold wire breaking in process of LED manufacturing and to secure high reliability.

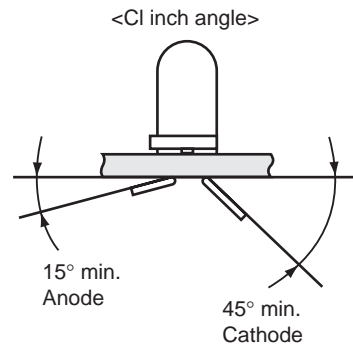

(1)Setting of automatic insertion machine

- ① Speed : not more than 1.0sec. / p.
- ② Chuch pressure : not more than 3.0kg / cm².
- ③ Head pressure : not more than 1.0kg / cm².
- ④ Clinch angle : bendingangle.
 - Anode side within 15°
 - Cathode side within 45°
- ⑤ Cutter : To avoid tearing lead off, use of sharp and hard cutter withstanding 1million time in preferable.

(2)Pre-hardening furnace

- ① Temperature : When hardening chips by adhesive at 150°C(120sec), set the surface temperature of LED resin part to 120°C or less ; even influence of increase in temperature to the back side of LED part is low. (Temperature of 130°C is about the line that causes deformation (heat deflection temperature) of resin used in standard LED. If temperature is increased while stress is on lead, even small, resin is softened and the life of held lead is lowered. This may cause gold wire breaking due to moving lead.)

(3)Solder dipping

- ① Temperature of soldering bath : 260°C or less.
- ② Dipping time : within 5sec.
- ③ Lead soldering condition : min 1.6mm from case.

 **CAUTION**

1. No products described or contained herein are intended for use in surgical implants, life-support systems, aerospace equipment, nuclear power control systems, vehicles, disaster / crime-prevention equipment or the like, and the failure of which may directly or indirectly cause injury, death or property loss.
2. Anyone purchasing any products described or contained herein for an above-mentioned use shall:
 - 1) Accept full responsibility and indemnify and defend SANYO ELECTRIC CO.,LTD., it's affiliates, subsidiaries and distributors or any of their officers and employees, jointly and severally, against any and all claims and litigation and all damages, costs and expenses associated with such use.
 - 2) Not impose any responsibility for any fault or negligence which may be cited in any such claim or litigation on SANYO ELECTRIC CO., LTD., it's affiliates, subsidiaries and distributors or any of their officers and employees jointly or severally.
3. Information (including circuit diagrams and circuit parameters) disclosed herein is for example only; it is not guaranteed for mass production, SANYO believes the information disclosed herein is accurate and reliable, but no guarantees are made or implied regarding it's use or any infringements of intellectual property rights or other rights of third parties.

Precautionary instructions in handling gallium arsenic products

Special precautions must be taken in handling this product because it contains, gallium arsenic, which is designated as a toxic substance by law. Be sure to adhere strictly to all applicable laws and regulations enacted for this substance, particularly when it comes to disposal.

Manufactured by ; **Tottori SANYO Electric Co., Ltd.**
LED Division
5-318, Tachikawa-cho, Tottori City, 680-8634 Japan
TEL: +81-857-21-2137 FAX: +81-857-21-2161