

## LOW VOLTAGE 14-BIT LINEAR CODEC WITH HIGH-PERFORMANCE AUDIO FRONT-END

**FEATURES:**
**Complete CODEC and FILTER system including:**

- 14 BIT LINEAR ANALOG TO DIGITAL AND DIGITAL TO ANALOG CONVERTERS.
- 8 BIT COMPANDED ANALOG TO DIGITAL AND DIGITAL TO ANALOG CONVERTERS A-LAW OR  $\mu$ -LAW.
- TRANSMIT AND RECEIVE BAND-PASS FILTERS
- ACTIVE ANTIALIAS NOISE FILTER.

**Phone Features:**

- THREE SWITCHABLE MICROPHONE AMPLIFIER INPUTS. GAIN PROGRAMMABLE: 20 dB PREAMP. (+MUTE), 0 . . 22.5 dB AMPLIFIER, 1.5 dB STEPS.
- EARPIECE AUDIO OUTPUT. ATTENUATION PROGRAMMABLE: 0 . . 30 dB, 2 dB STEPS.
- EXTERNAL AUDIO OUTPUT. ATTENUATION PROGRAMMABLE: 0 . . 30 dB, 2 dB STEPS.
- TRANSIENT SUPPRESSION SIGNAL DURING POWER ON AND DURING AMPLIFIER SWITCHING.
- INTERNAL PROGRAMMABLE SIDETONE CIRCUIT. ATTENUATION PROGRAMMABLE: 16 dB RANGE, 1 dB STEP. ROUTING POSSIBLE TO BOTH OUTPUTS.
- INTERNAL RING OR TONE GENERATOR INCLUDING DTMF TONES, SINEWAVE OR SQUAREWAVE WAVEFORMS. ATTENUATION PROGRAMMABLE: 27dB RANGE, 3dB STEP. THREE FREQUENCY RANGES:
  - a) 3.9Hz . . . . 996Hz, 3.9Hz STEP
  - b) 7.8Hz . . . . 1992Hz, 7.8Hz STEP
  - c) 15.6Hz . . . . 3984Hz, 15.6Hz STEP
- PROGRAMMABLE PULSE WIDTH MODULATED BUZZER DRIVER OUTPUT.

**General Features:**

- SINGLE 3.3V  $\pm$ 10% OR 5V  $\pm$ 10% SUPPLY SELECTABLE.
- EXTENDED TEMPERATURE RANGE OPERATION (\*) -40°C to 85°C.
- 1.5  $\mu$ W STANDBY POWER (TYP. AT 3V).
- 21 mW OPERATING POWER (TYP. AT 3V).
- CMOS COMPATIBLE DIGITAL INTERFACES.
- PROGRAMMABLE PCM AND CONTROL INTERFACE MICROWIRE COMPATIBLE.

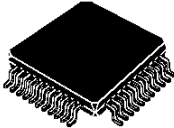
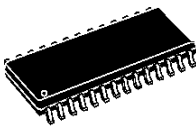
			
TQFP44(10x10x1.4)	SO28		
<b>ORDERING NUMBERS:</b>			
	<b>Package</b>	<b>Dim.</b>	<b>Cond.</b>
ST5090AD	SO28		Tube
ST5090ADTR	SO28		Tape&Reel
ST5090TQFP	TQFP44	10x10x1.4	Tray 8x20
ST5090TQFPTR	TQFP44	10x10x1.4	Tape&Reel

**APPLICATIONS:**

- GSM DIGITAL CELLULAR TELEPHONES.
- CT2 DIGITAL CORDLESS TELEPHONES.
- DECT DIGITAL CORDLESS TELEPHONES.
- BATTERY OPERATED AUDIO FRONT-ENDS FOR DSPs.

(\*) Functionality guaranteed in the range - 40°C to +85°C;  
Timing and Electrical Specifications are guaranteed in the range - 30°C to +85°C.

**GENERAL DESCRIPTION**

ST5090 is a high performance low power combined PCM CODEC/FILTER device tailored to implement the audio front-end functions required by the next generation low voltage/low power consumption digital terminals.

ST5090 offers a number of programmable functions accessed through a serial control channel that easily interfaces to any classical microcontroller. The PCM interface supports both non-delayed (normal and reverse) and delayed frame synchronization modes.

ST5090 can be configured either as a 14-bit linear or as an 8-bit companded PCM coder. Additionally to the CODEC/FILTER function, ST5090 includes a Tone/Ring/DTMF generator, a sidetone generation, and a buzzer driver output. ST5090 fulfills and exceeds D3/D4 and CCITT recommendations and ETSI requirements for digital handset terminals.

Main applications include digital mobile phones, as cellular and cordless phones, or any battery powered equipment that requires audio codecs operating at low single supply voltages

# ST5090

## PIN CONNECTIONS (Top view)

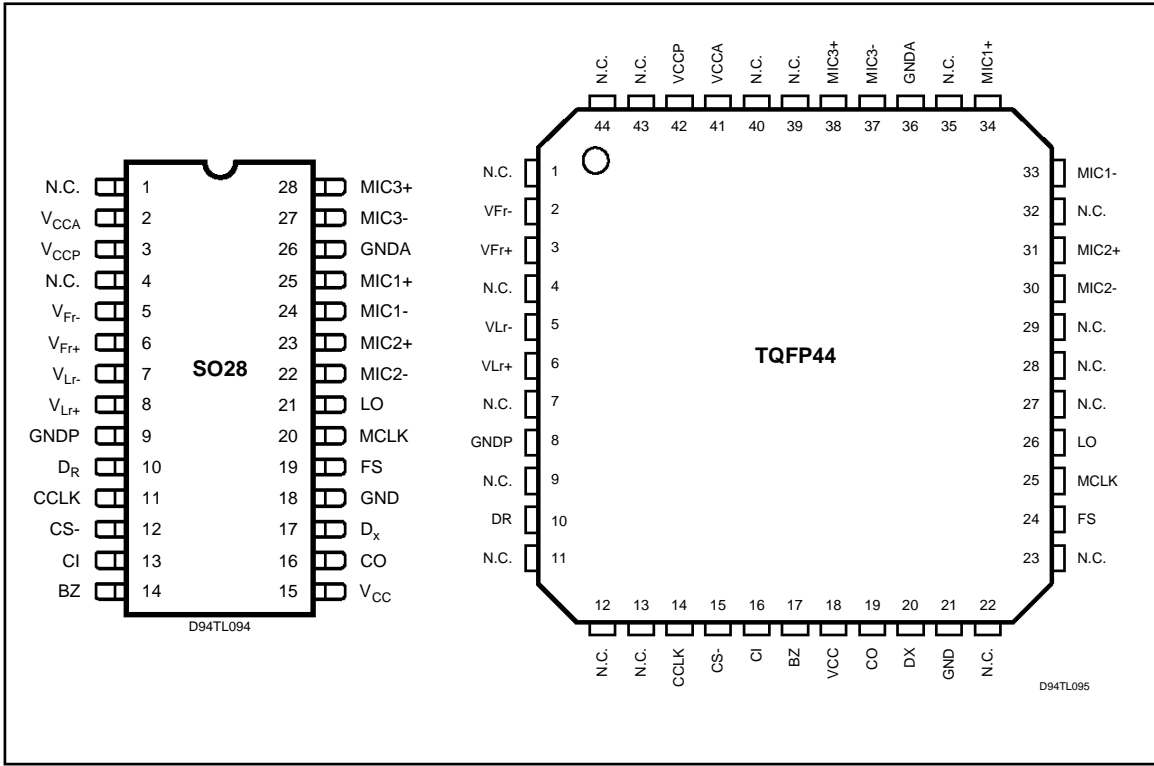

## BLOCK DIAGRAM

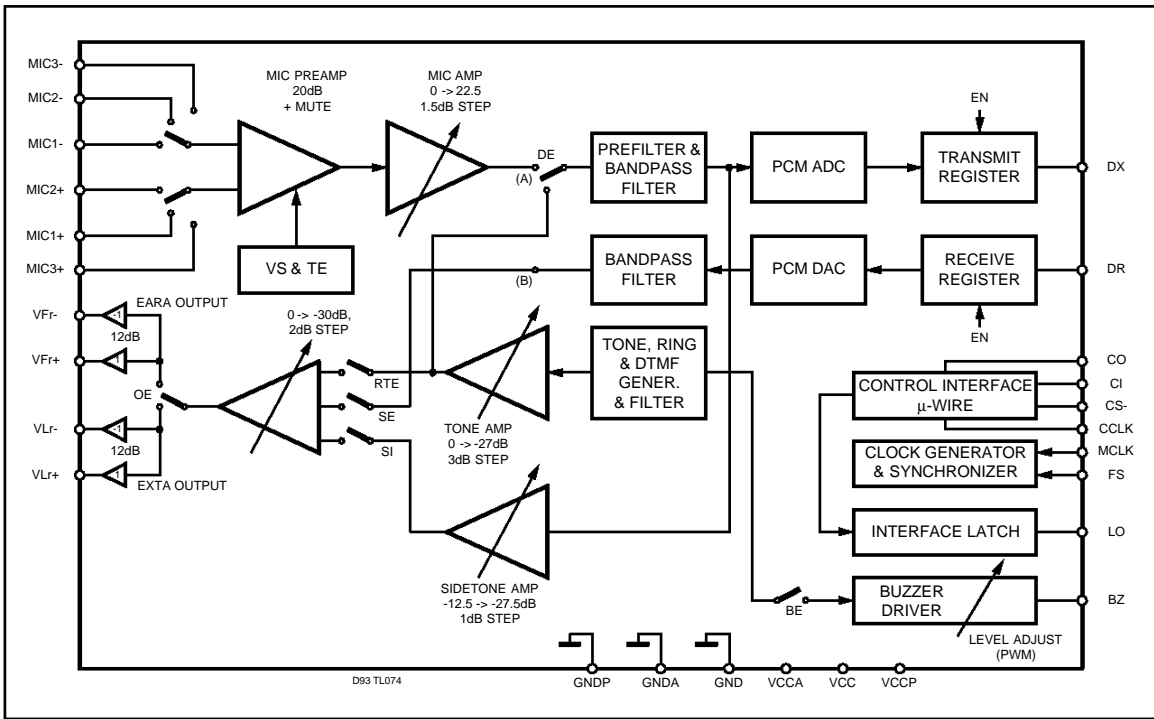

## PIN FUNCTIONS (SO28)

Pin	Name	Description
1	N.C.	Not Connected.
2	V <sub>CCA</sub>	Positive power supply input for the analog section. +5V ±10% or 3.3V ±10% selectable. V <sub>CC</sub> and V <sub>CCA</sub> must be directly connected together.
3	V <sub>CCP</sub>	Positive power supply input for the power section. 5V ±10% or 3.3V ±10% selectable V <sub>CCP</sub> and V <sub>CC</sub> must be connected together.
4	N.C.	Not Connected.
5,6	V <sub>Fr+</sub> , V <sub>Fr-</sub>	Receive analog earpiece amplifier complementary outputs. These outputs can drive directly earpiece transducer. The signal at this output can be the sum of: - Receive Speech signal from D <sub>R</sub> , - Internal Tone Generator, - Sidetone signal.
7,8	V <sub>Lr+</sub> , V <sub>Lr-</sub>	Receive analog extra amplifier complementary outputs. The signal at these outputs can be the sum of: - Receive Speech signal from D <sub>R</sub> , - Internal Tone generator, - Sidetone signal.
9	GNDP	Power ground. V <sub>Fr</sub> and V <sub>Lr</sub> driver are referenced to this pin. GNDP and GND must be connected together close to the device.
10	D <sub>R</sub>	Receive data input: Data is shifted in during the assigned Received time slots. In delayed and non-delayed normal frame synchr. modes voice data byte is shifted in at the MCLK frequency on the falling edges of MCLK, while in non-delayed reverse frame synchr. mode voice data byte is shifted in at the MCLK frequency on the rising edges of MCLK.
11	CCLK	Control Clock input: This clock shifts serial control information into CI and out from CO when the CS- input is low, depending on the current instruction. CCLK may be asynchronous with the other system clocks.
12	CS-	Chip Select input: When this pin is low, control information is written into and out from the ST5090 via CI and CO pins.
13	CI	Control data Input: Serial Control information is shifted into the ST5090 on this pin when CS- is low on the rising edges of CCLK.
14	BZ	Pulse width modulated buzzer driver output.
15	V <sub>CC</sub>	Positive power supply input for the digital section. +5V ±10% or 3.3V ±10% selectable.
16	CO	Control data Output: Serial control/status information is shifted out from the ST5090 on this pin when CS- is low on the falling edges of CCLK.
17	D <sub>X</sub>	Transmit Data output: Data is shifted out on this pin during the assigned transmit time slots. Elsewhere D <sub>X</sub> output is in the high impedance state. In delayed and non-delayed normal frame synchr. modes, voice data byte is shifted out from TRISTATE output D <sub>X</sub> at the MCLK on the rising edge of MCLK, while in non-delayed reverse frame synchr mode voice data byte is shifted out on the falling edge of MCLK.
18	GND	Ground: All digital signals are referenced to this pin.
19	FS	Frame Sync input: This signal is a 8kHz clock which defines the start of the transmit and receive frames. Any of three formats may be used for this signal: non delayed normal mode, delayed mode, and non delayed reverse mode.
20	MCLK	Master Clock Input: This signal is used by the switched capacitor filters and the encoder/decoder sequencing logic. Values must be 512 kHz, 1.536 MHz, 2.048 MHz or 2.56 MHz selected by means of Control Register CRO. MCLK is used also to shift-in and out data.
21	LO	A logic 1 written into DO (CR1) appears at LO pin as a logic 0 A logic 0 written into DO (CR1) appears at LO pin as a logic 1.
22	MIC2-	Second negative high impedance input to transmit pre-amplifier for microphone connection.
23	MIC2+	Second Positive high impedance input to transmit pre-amplifier for microphone connection.
24	MIC1-	Negative high impedance input to transmit pre-amplifier for microphone connection.
25	MIC1+	Positive high impedance input to transmit pre-amplifier for microphone connection.
26	GNDA	Analog Ground: All analog signals are referenced to this pin. GND and GNDA must be connected together close to the device.
27	MIC3-	Third negative high impedance output to transmit preamplifier for microphone connection.
28	MIC3+	Third positive high impedance output to transmit preamplifier for microphone connection.

## PIN FUNCTIONS (TQFP44)

Pin	Name	Description
1	N.C.	Not Connected.
2,3	V <sub>Fr+</sub> , V <sub>Fr-</sub>	Receive analog earpiece amplifier complementary outputs. These outputs can drive directly earpiece transducer. The signal at this output can be the summ of: - Receive Speech signal from D <sub>R</sub> , - Internal Tone Generator, - Sidetone signal.
4	N.C.	Not Connected.
5,6	V <sub>Lr+</sub> , V <sub>Lr-</sub>	Receive analog extra amplifier complementary outputs. The signal at these outputs can be the sum of: - Receive Speech signal from DR, - Internal Tone generator, - Sidetone signal.
7	N.C.	Not Connected.
8	GNDP	Power ground. V <sub>Fr</sub> and V <sub>Lr</sub> driver are referenced to this pin. GNDP and GND must be connected together close to the device.
9	N.C.	Not Connected.
10	D <sub>R</sub>	Receive data input: Data is shifted in during the assigned Received time slots In delayed and non-delayed normal frame synchr. modes voice data byte is shifted in at the MCLK frequency on the falling edges of MCLK, while in non-delayed reverse frame synchr. mode voice data byte is shifted in at the MCLK frequency on the rising edges of MCLK.
11,12,13	N.C.	Not Connected.
14	CCLK	Control Clock input: This clock shifts serial control information into CI and out from CO when the CS- input is low, depending on the current instruction. CCLK may be asynchronous with the other system clocks.
15	CS-	Chip Select input: When this pin is low, control information is written into and out from the ST5090 via CI and CO pins.
16	CI	Control data Input: Serial Control information is shifted into the ST5090 on this pin when CS- is low on the rising edges of CCLK.
17	BZ	Pulse width modulated buzzer driver output.
18	V <sub>CC</sub>	Positive power supply input for the digital section. +5V ±10% or 3.3V ±10% selectable.
19	CO	Control data Output: Serial control/status information is shifted out from the ST5090 on this pin when CS- is low on the falling edges of CCLK.
20	D <sub>X</sub>	Transmit Data output: Data is shifted out on this pin during the assigned transmit time slots. Elsewhere D <sub>X</sub> output is in the high impedance state. In delayed and non-delayed normal frame synchr. modes, voice data byte is shifted out from TRISTATE output D <sub>X</sub> at the MCLK on the rising edge of MCLK, while in non-delayed reverse frame synchr mode voice data byte is shifted out on the falling edge of MCLK.
21	GND	Ground: All digital signals are referenced to this pin.
22,23	N.C.	Not Connected.
24	FS	Frame Sync input: This signal is a 8kHz clock which defines the start of the transmit and receive frames. Either of three formats may be used for this signal: non delayed normal mode, delayed mode, and non delayed reverse mode.
25	MCLK	Master Clock Input: This signal is used by the switched capacitor filters and the encoder/decoder sequencing logic. Values must be 512 kHz, 1.536 MHz, 2.048 MHz or 2.56 MHz selected by means of Control Register CRO. MCLK is used also to shift-in and out data.
26	LO	A logic 1 written into DO (CR1) appears at LO pin as a logic 0 A logic 0 written into DO (CR1) appears at LO pin as a logic 1.
27,28,29	N.C.	Not Connected.
30	MIC2-	Second negative high impedance input to transmit pre-amplifier for microphone connection.
31	MIC2+	Second Positive high impedance input to transmit pre-amplifier for microphone connection.
32	N.C.	Not Connected.
33	MIC1-	Negative high impedance input to transmit pre-amplifier for microphone connection.
34	MIC1+	Positive high impedance input to transmit pre-amplifier for microphone connection.
35	N.C.	Not Connected.
36	GND A	Analog Ground: All analog signals are referenced to this pin. GND and GND A must be connected together close to the device.
37	MIC3-	Third negative high impedance output to transmit preamplifier for microphone connection.
38	MIC3+	Third positive high impedance output to transmit preamplifier for microphone connection.
39,40	N.C.	Not Connected.
41	V <sub>CCA</sub>	Positive power supply input for the analog section. +5V ±10% or 3.3V ±10% selectable. V <sub>CC</sub> and V <sub>CCA</sub> must be directly connected together.
42	V <sub>CCP</sub>	Positive power supply input for the power section. 5V ±10% or 3.3V ±10% selectable V <sub>CCP</sub> and V <sub>CC</sub> must be connected together.
43,44	N.C.	Not Connected.

## FUNCTIONAL DESCRIPTION

### I DEVICE OPERATION

#### I.1 Power on initialization:

When power is first applied, power on reset circuitry initializes ST5090 and puts it into the power down state. Gain Control Registers for the various programmable gain amplifiers and programmable switches are initialized as indicated in the Control Register description section. All CODEC functions are disabled.

The desired selection for all programmable functions may be initialized prior to a power up command using the MICROWIRE control channel.

#### I.2 Power up/down control:

Following power-on initialization, power up and power down control may be accomplished by writing any of the control instructions listed in Table 1 into ST5090 with "P" bit set to 0 for power up or 1 for power down.

Normally, it is recommended that all programmable functions be initially programmed while the device is powered down. Power state control can then be included with the last programming instruction or in a separate single byte instruction.

Any of the programmable registers may also be modified while ST5090 is powered up or down by setting "P" bit as indicated. When power up or down control is entered as a single byte instruction, bit 1 must be set to a 0.

When a power up command is given, all de-activated circuits are activated, but output  $D_X$  will remain in the high impedance state until the second  $F_s$  pulse after power up.

#### I.3 Power down state:

Following a period of activity, power down state may be reentered by writing a power down instruction.

Control Registers remain in their current state and can be changed by MICROWIRE control interface.

In addition to the power down instruction, detection of loss MCLK (no transition detected) automatically enters the device in "reset" power down state with  $D_X$  output in the high impedance state.

#### I.4 Transmit section:

Transmit analog interface is designed in two stages to enable gains up to 42.5 dB to be realized. Stage 1 is a low noise differential amplifier providing 20 dB gain. A microphone may be capacitively connected to MIC1+, MIC1- inputs, while the MIC2+ MIC2- and MIC3+ MIC3- inputs may be used to capacitively connect a second microphone or a third microphone respectively or an auxiliary audio circuit. MIC1 or MIC2 or MIC3 or transmit mute is selected with bits 6 and 7 of register CR4.

In the mute case, the analog transmit signal is grounded and the sidetone path is also disabled. Following the first stage is a programmable gain amplifier which provides from 0 to 22.5 dB of additional gain in 1.5dB step. The total transmit gain should be adjusted so that, at reference point A, see Block Diagram description, the internal 0 dBm0 voltage is 0.49 Vrms (overload level is 0.7 Vrms). Second stage amplifier gain can be programmed with bits 4 to 7 of CR5.

An active RC prefilter then precedes the 8th order band pass switched capacitor filter. A/D converter can be either a 14-bit linear (bit CM = 0 in register CR0) or can have a compressing characteristics (bit CM = 1 in register CR0) according to CCITT A or MU255 coding laws. A precision on chip voltage reference ensures accurate and highly stable transmission levels.

Any offset voltage arising in the gain-set amplifier, the filters or the comparator is cancelled by an internal autozero circuit.

Each encode cycle begins immediately at the beginning of the selected Transmit time slot. The total signal delay referenced to the start of the time slot is approximately 195  $\mu$ s (due to the transmit filter) plus 125  $\mu$ s (due to encoding delay), which totals 320  $\mu$ s. Voice data is shifted out on  $D_X$  during the selected time slot on the transmit rising edges of MCLK in delayed or non-delayed normal mode or on the falling edges of MCLK in non-delayed reverse mode.

#### I.5 Receive section:

Voice Data is shifted into the decoder's Receive voice data Register via the  $D_R$  pin during the selected time slot on the falling edges of MCLK in delayed or non-delayed normal mode or on the rising edges of MCLK in non-delayed reverse mode.

The decoder consists of either a 14-bit linear or an expanding DAC with A or MU255 law decoding characteristic. Following the Decoder is a 3400 Hz 8th order band-pass switched capacitor filter with integral Sin X/X correction for the 8 kHz sample and hold.

0 dBm0 voltage at this (B) reference point (see Block Diagram description) is 0.49 Vrms. A transient suppressing circuitry ensure interference noise suppression at power up.

The analog speech signal output can be routed either to earpiece ( $V_{FR+}$ ,  $V_{FR-}$  outputs) or to an extra analog output ( $V_{LR+}$ ,  $V_{LR-}$  outputs) by setting bits OE and SE (1 and 0 of CR4).

Total signal delay is approximately 190  $\mu$ s (filter plus decoding delay) plus 62.5  $\mu$ s (1/2 frame) which gives approximately 252  $\mu$ s.

Differential outputs  $V_{FR+}$ ,  $V_{FR-}$  are intended to directly drive an earpiece. Preceding the outputs is a programmable attenuation amplifier, which must

be set by writing to bits 4 to 7 in register CR6. Attenuations in the range 0 to -30 dB relative to the maximum level in 2 dB step can be programmed. The input of this programmable amplifier is the sum of several signals which can be selected by writing to register CR4.:

- Receive speech signal which has been decoded and filtered,
- Internally generated tone signal, (Tone amplitude is programmed with bits 4 to 7 of register CR7),
- Sidetone signal, the amplitude of which is programmed with bits 0 to 3 of register CR5

$V_{FR+}$  and  $V_{FR-}$  outputs are capable of driving output power level up to 66mW into differentially connected load impedance of 30  $\Omega$ . Piezoceramic receivers up to 50nF can also be driven.

Differential outputs  $V_{Lr+}$ ,  $V_{Lr-}$  are intended to directly drive an extra output. Preceding the outputs is a programmable attenuation amplifier, which must be set by writing to bits 0 to 3 in register CR6. Attenuations in the range 0 to -30 dB relative to the maximum level in 2.0 dB step can be programmed. The input of this programmable amplifier can be the sum of signals which can be selected by writing to register CR4:

- Receive speech signal which has been decoded and filtered,
- Internally generated tone signal, (Tone amplitude is programmed with bits 4 to 7 of register CR7),
- Sidetone signal, the amplitude of which is programmed with bits 0 to 3 of register CR5.

$V_{Lr+}$  and  $V_{Lr-}$  outputs are capable of driving output power level up to 66mW into differentially connected load impedance of 30  $\Omega$ . Piezoceramic receivers up to 50nF can also be driven.

#### BUZZER OUTPUT:

Single ended output BZ is intended to drive a buzzer, via an external BJT, with a squarewave pulse width modulated (PWM) signal the frequency of which is stored into register CR8.

For some applications it is also possible to amplitude modulate this PWM signal with a squarewave signal having a frequency stored in register CR9.

Maximum load for BZ is 5k $\Omega$  and 50pF.

#### I.6 Digital Interface (Fig. 1)

$F_S$  Frame Sync input determines the beginning of frame. It may have any duration from a single cycle of MCLK to a squarewave. Three different relationships may be established between the Frame Sync input and the first time slot of frame by setting bits DM1 and DM0 in register CR1.

Non delayed data mode is similar to long frame timing on ST5080A: first time slot begins nominally coincident with the rising edge of  $F_S$ . Alternative is to use delayed data mode, which is similar to short frame sync timing on ST5080A, in which  $F_S$  input must be high at least a half cycle of MCLK earlier the frame beginning. In the case of companded code only (bit CM = 1 in register CRO) a time slot assignment circuit on chip may be used with all timing modes, allowing connection to one of the two B1 and B2 voice data channels.

Two data formats are available: in Format 1, time slot B1 corresponds to the 8 MCLK cycles following immediately the rising edge of  $F_S$ , while time slot B2 corresponds to the 8 MCLK cycles following immediately time slot B1.

In Format 2, time slot B1 is identical to Format 1. Time slot B2 appears two bit slots after time slot B1. This two bits space is left available for insertion of the D channel data.

Data format is selected by bit FF (2) in register CR0. Time slot B1 or B2 is selected by bit TS (1) in Control Register CR1.

Bit EN (2) in control register CR1 enables or disables the voice data transfer on  $D_X$  and  $D_R$  as appropriate. During the assigned time slot,  $D_X$  output shifts data out from the voice data register on the rising edges of MCLK in the case of delayed and non-delayed normal modes or on the falling edges of MCLK in the case of non-delayed reverse mode. Serial voice data is shifted into  $D_R$  input during the same time slot on the falling edges of MCLK in the case of delayed and non-delayed normal modes or on the rising edges of MCLK in the case of non-delayed reverse mode.  $D_X$  is in the high impedance Tristate condition when in the non selected time slots.

#### I.7 Control Interface:

Control information or data is written into or read-back from ST5090 via the serial control port consisting of control clock CCLK, serial data input CI and output CO, and Chip Select input, CS-. All control instructions require 2 bytes as listed in Table 1, with the exception of a single byte power-up/down command.

To shift control data into ST5090, CCLK must be pulsed high 8 times while CS- is low. Data on CI input is shifted into the serial input register on the rising edge of each CCLK pulse. After all data is shifted in, the content of the input shift register is decoded, and may indicate that a 2nd byte of control data will follow. This second byte may either be defined by a second byte-wide CS-pulse or may follow the first contiguously, i.e. it is not mandatory for CS- to return high in between the first and second control bytes. At the end of the 2nd control byte, data is loaded into the ap-

Figure 1: Digital Interface Format (\*)

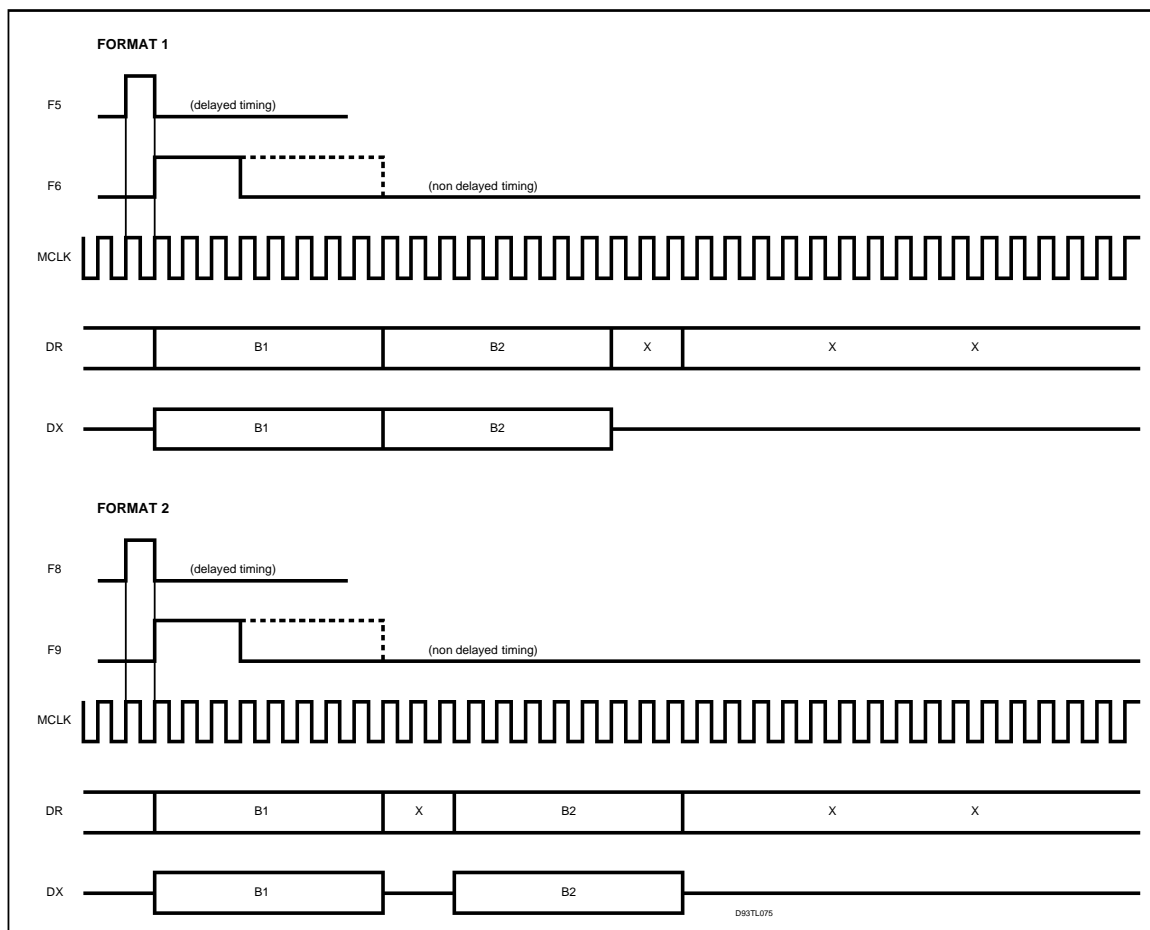

(\*) Significant Only For Companded Code.

appropriate programmable register. CS- must return high at the end of the 2nd byte.

To read-back status information from ST5090, the first byte of the appropriate instruction is strobed in during the first CS- pulse, as defined in Table 1. CS- must be set low for a further 8 CCLK cycles, during which data is shifted out of the CO pin on the falling edges of CCLK.

When CS- is high, CO pin is in the high impedance Tri-state, enabling CO pins of several devices to be multiplexed together.

Thus, to summarise, 2 byte READ and WRITE instructions may use either two 8-bit wide CS- pulses or a single 16 bit wide CS- pulse.

#### I.8 Control channel access to PCM interface:

It is possible to access the B channel previously

selected in Register CR1 in the case of companded code only.

A byte written into Control Register CR3 will be automatically transmitted from D<sub>X</sub> output in the following frame in place of the transmit PCM data. A byte written into Control Register CR2 will be automatically sent through the receive path to the Receive amplifiers.

In order to implement a continuous data flow from the Control MICROWIRE interface to a B channel, it is necessary to send the control byte on each PCM frame.

A current byte received on D<sub>R</sub> input can be read in the register CR2. In order to implement a continuous data flow from a B channel to MICROWIRE interface, it is necessary to read register CR2 at each PCM frame.

## ST5090

### II PROGRAMMABLE FUNCTIONS

For both formats of Digital Interface, programmable functions are configured by writing to a number of registers using a 2-byte write cycle. Most of these registers can also be read-back for

verification. Byte one is always register address, while byte two is Data.

Table 1 lists the register set and their respective addresses.

**Table 1:** Programmable Register Instructions

Function	Address byte								Data byte
	7	6	5	4	3	2	1	0	
Single byte Power up/down	P	X	X	X	X	X	0	X	none
Write CR0	P	0	0	0	0	0	1	X	see CR0 TABLE 2
Read-back CR0	P	0	0	0	0	1	1	X	see CR0
Write CR1	P	0	0	0	1	0	1	X	see CR1 TABLE 3
Read-back CR1	P	0	0	0	1	1	1	X	see CR1
Write Data to receive path	P	0	0	1	0	0	1	X	see CR2 TABLE 4
Read data from D <sub>R</sub>	P	0	0	1	0	1	1	X	see CR2
Write Data to D <sub>X</sub>	P	0	0	1	1	0	1	X	see CR3 TABLE 5
Write CR4	P	0	1	0	0	0	1	X	see CR4 TABLE 6
Read-back CR4	P	0	1	0	0	1	1	X	see CR4
Write CR5	P	0	1	0	1	0	1	X	see CR5 TABLE 7
Read-back CR5	P	0	1	0	1	1	1	X	see CR5
Write CR6	P	0	1	1	0	0	1	X	see CR6 TABLE 8
Read-back CR6	P	0	1	1	0	1	1	X	see CR6
Write CR7	P	0	1	1	1	0	1	X	see CR7 TABLE 9
Read-back CR7	P	0	1	1	1	1	1	X	see CR7
Write CR8	P	1	0	0	0	0	1	X	see CR8 TABLE 10
Read-back CR8	P	1	0	0	0	1	1	X	see CR8
Write CR9	P	1	0	0	1	0	1	X	see CR9 TABLE 11
Read-back CR9	P	1	0	0	1	1	1	X	see CR9
Write CR10	P	1	0	1	0	0	1	X	see CR10 TABLE 12
Read-back CR10	P	1	0	1	0	1	1	X	see CR10
Write CR11	P	1	0	1	1	0	1	X	see CR11 TABLE 13
Read-back CR11	P	1	0	1	1	1	1	X	see CR11
Write Test Register CR14	P	1	1	1	0	0	1	X	reserved

NOTE 1: bit 7 of the address byte and data byte is always the first bit clocked into or out from: CI and CO pins when MICROWIRE serial port is enabled.  
X = reserved: write 0

NOTE 2: "P" bit is Power up/down Control bit. P = 1 Means Power Down.  
Bit 1 indicates, if set, the presence of a second byte.

NOTE 3: Bit 2 is write/read select bit.

NOTE 4: Registers CR12, CR13, and CR15 are not accessible.

**Table 2:** Control Register CR0 Functions

7	6	5	4	3	2	1	0	Function
F1	F0	CM	MA	IA	FF	B7	DL	
0	0							MCLK = 512 kHz *
0	1							MCLK = 1.536 MHz
1	0							MCLK = 2.048 MHz
1	1							MCLK = 2.560 MHz
		0						Linear code *
		1						Companded code
								Linear Code
								Companded Code
			0	0				2-complement sign and magnitude *
			0	1				MU-law: CCITT D3-D4 *
			1	0				MU-law: Bare Coding
			1	1				A-law including even bit inversion
								A-law: Bare Coding
					0			B1 and B2 consecutive *
					1			B1 and B2 separated (1)
						0		8 bits time-slot *
						1		7 bits time-slot (1)
							0	Normal operation *
							1	Digital Loop-back

\*: state at power on initialization

(1): significant in companded mode only

**Table 3:** Control Register CR1 Functions

7	6	5	4	3	2	1	0	Function
DM1	DM0	DO	MR	MX	EN	TS	SV	
0	X							delayed data timing *
1	0							non-delayed normal data timing
1	1							non-delayed reverse data timing
		0						L0 latch set to 1 *
		1						L0 latch set to 0
			0					D <sub>R</sub> connected to rec. path *
			1					CR2 connected to rec. path (1)
				0				Trans path connected to D <sub>x</sub> *
				1				CR3 connected to D <sub>x</sub> (1)
					0			voice data transfer disable *
					1			voice data transfer enable
						0		B1 channel selected *
						1		B2 channel selected (1)
							0	3.3V power supply *
							1	5.0V power supply

\*: state at power on initialization

(1): significant in companded mode only

**Table 4:** Control Register CR2 Functions

7	6	5	4	3	2	1	0	Function
d7	d6	d5	d4	d3	d2	d1	d0	
msb							lsb	Data sent to Receive path or Data received from D <sub>R</sub> input (1)

(1) Significant in companded mode only.

**Table 5:** Control Registers CR3 Functions

7	6	5	4	3	2	1	0	Function
d7	d6	d5	d4	d3	d2	d1	d0	
msb							lsb	D <sub>X</sub> data transmitted (1)

(1) Significant in companded mode only

**Table 6:** Control Register CR4 Functions

7	6	5	4	3	2	1	0	Function
VS	TE	SI	OE1	OE2	RTE		SE	
0	0							Transmit input muted *
0	1							MIC1 Selected
1	0							MIC2 Selected
1	1							MIC3 Selected
		0						Internal sidetone disabled *
		1						Internal sidetone enabled
			0	0				Receive output muted *
			0	1				V <sub>F<sub>r</sub></sub> output selected
			1	0				V <sub>L<sub>r</sub></sub> output selected
			1	1				NOT ALLOWED
					0			Ring / Tone to V <sub>F<sub>r</sub></sub> or V <sub>L<sub>r</sub></sub> disabled *
					1			Ring / Tone to V <sub>F<sub>r</sub></sub> or V <sub>L<sub>r</sub></sub> enabled
						X		
							0	Receive Signal to V <sub>F<sub>r</sub></sub> or V <sub>L<sub>r</sub></sub> disabled *
							1	Receive Signal to V <sub>F<sub>r</sub></sub> or V <sub>L<sub>r</sub></sub> enabled

\*: state at power on initialization

X: reserved: write 0

**Table 7:** Control Register CR5 Functions

7	6	5	4	3	2	1	0	Function
Transmit amplifier				Sidetone amplifier				
0	0	0	0					0 dB gain *
0	0	0	1					1.5 dB gain
-	-	-	-					in 1.5 dB step
1	1	1	1					22.5 dB gain
				0	0	0	0	-12.5 dB gain *
				0	0	0	1	-13.5 dB gain
				-	-	-	-	in 1 dB step
				1	1	1	1	-27.5 dB gain

\*: state at power on initialization

**Table 8:** Control Register CR6 Functions

7	6	5	4	3	2	1	0	Function
Earpiece amplifier [EARA]				Extra amplifier [EXTA]				
0	0	0	0					0 dB gain *
0	0	0	1					-2 dB gain
-	-	-	-					in 2 dB step
1	1	1	1					-30 dB gain
				0	0	0	0	0 dB gain *
				0	0	0	1	-2 dB gain
				-	-	-	-	in 2 dB step
				1	1	1	1	-30 dB gain

\*: state at power on initialization

**Table 9:** Control Register CR7 Functions

7	6	5	4	3	2	1	0	Function		
Tone gain				F1	F2	SN	DE	Attenuation	f1 V <sub>pp</sub>	f2 V <sub>pp</sub>
0	0	0	0					0 dB *	1.6(2)	1.26(2)
0	0	0	1					-3 dB		
0	0	1	0					-6 dB		
0	0	1	1					-9 dB		
0	1	0	0					-12 dB		
0	1	0	1					-15 dB		
0	1	1	0					-18 dB		
0	1	1	1					-21 dB		
1	X	X	0					-24 dB		
1	X	X	1					-27 dB	0.066	0.053
				0	0			f1 and f2 muted		*
				0	1			f2 selected		
				1	0			f1 selected		
				1	1			f1 and f2 in summed mode		
						0		Squarewave signal selected		*
						1		Sinewave signal selected		
							0	Normal operation		*
							1	Tone / Ring Generator connected to Transmit path		

\*: state at power on initialization

(2): value provided if f1 or f2 is selected alone.  
if f1 and f2 are selected in the summed mode, f1=0.89 V<sub>pp</sub> while f2=0.7 V<sub>pp</sub>.

X reserved: write 0

**Table 10:** Control Register CR8 Functions

7	6	5	4	3	2	1	0	Function
f17	f16	f15	f14	f13	f12	f11	f10	
msb							lsb	Binary equivalent of the decimal number used to calculate f1

**Table 11:** Control Register CR9 Functions

7	6	5	4	3	2	1	0	Function
f27	f26	f25	f24	f23	f22	f21	f20	
msb							lsb	Binary equivalent of the decimal number used to calculate f2

**Table 12:** Control Register CR10 Functions

7	6	5	4	3	2	1	0	Function
						DFT	HFT	
X	X	X	X	X	X			
						0	0	(*) Standard Frequency Tone Range
						0	1	Halved Frequency Tone Range
						1	0	Doubled Frequency Tone Range
						1	1	Forbidden

(\*) Default values inserted into the Register at Power On.

X reserved, write 0.

**Table 13:** Control Register CR11 Functions

7	6	5	4	3	2	1	0	Function
BE	BI	BZ5	BZ4	BZ3	BZ2	BZ1	BZ0	
0								Buzzer output disabled (set to 0) *
1								Buzzer output enabled
	0							Duty Cycle is intended as the relative width of logic 1 *
	1							Duty cycle is intended as the relative width of logic 0
		msb					lsb	Binary equivalent of the decimal number used to calculate the duty cycle.

\* state at power on initialization

**CONTROL REGISTER CR0**

First byte of a READ or a WRITE instruction to Control Register CR0 is as shown in TABLE 1. Second byte is as shown in TABLE 2.

**Master Clock Frequency Selection**

A master clock must be provided to ST5090 for operation of filter and coding/decoding functions. MCLK frequency can be either 512 kHz, 1.536 MHz, 2.048 MHz or 2.56 MHz.

Bit F1 (7) and F0 (6) must be set during initialization to select the correct internal divider.

Default value is 512 kHz.

Any clock different from the default one must be selected prior a Power-Up instruction.

**Coding Law Selection**

Bits MA (4) and IA (3) permit selection of Mu-255 law or A law coding with or without even bit inversion if companded code (bit CM = 1) is selected. Bits MA(4) and IA(3) permit selection of 2-complement, 1-complement or sign and magnitude if linear code (bit CM = 0) is selected.

**Coding Selection**

Bit CM (5) permits selection either of linear coding (14-bit) or companded coding (8-bit). Default value is linear coding.

**Digital Interface format (1)**

Bit FF(2) = 0 selects digital interface in Format 1 where B1 and B2 channel are consecutive. FF=1 selects Format 2 where B1 and B2 channel are separated by two bits. (See digital interface format section.)

**56+8 selection (1)**

Bit 'B7' (1) selects capability for ST5090 to take into account only the seven most significant bits of the PCM data byte selected.

When 'B7' is set, the LSB bit on D<sub>R</sub> is ignored and LSB bit on D<sub>X</sub> is high impedance. This function allows connection of an external "in band" data generator directly connected on the Digital Interface.

**Digital loopback**

Digital loopback mode is entered by setting DL bit(0) equal 1.

In Digital Loopback mode, data written into Receive PCM Data Register from the selected received time-slot is read-back from that Register in the selected transmit time-slot on D<sub>X</sub>.

No PCM decoding or encoding takes place in this mode. Transmit and Receive amplifier stages are muted.

**CONTROL REGISTER CR1**

First byte of a READ or a WRITE instruction to Control Register CR1 is as shown in TABLE 1. Second byte is as shown in TABLE 3.

**Digital Interface Timing**

Bit DM1(7) = 0 selects digital interface in delayed timing mode, while DM1 = 1 and DM0 = 0 selects non-delayed normal data timing mode, and DM1 = 1 and DM0 = 1 selects non-delayed reverse data timing mode.

Default is delayed data timing.

**Latch output control**

Bit DO controls directly logical status of latch output LO: ie, a "ZERO" written in bit DO puts the output LO at logical 1, while a "ONE" written in bit DO sets the output LO to zero.

**Microwire access to B channel on receive path (1)**

Bit MR (4) selects access from MICROWIRE Register CR2 to Receive path. When bit MR is set high, data written to register CR2 is decoded each frame, sent to the receive path and data input at D<sub>R</sub> is ignored.

In the other direction, current PCM data input received at D<sub>R</sub> can be read from register CR2 each frame.

**Microwire access to B channel on transmit path (1)**

Bit MX (3) selects access from MICROWIRE write only Register CR3 to D<sub>X</sub> output. When bit MX is set high, data written to CR3 is output at D<sub>X</sub> every frame and the output of PCM encoder is ignored.

(1) Significant in companded mode only

	Mu 255 law								True A law even bit inversion								A law without even bit inversion										
	msb				lsb				msb				lsb				msb				lsb						
V <sub>in</sub> = + full scale	1	0	0	0	0	0	0	0	0	1	0	1	0	1	0	1	0	1	1	1	1	1	1	1	1	1	1
V <sub>in</sub> = 0 V	1	1	1	1	1	1	1	1	1	1	1	0	1	0	1	0	1	1	1	0	0	0	0	0	0	0	0
V <sub>in</sub> = - full scale	0	0	0	0	0	0	0	0	0	0	0	1	0	1	0	1	0	0	1	1	1	1	1	1	1	1	1

MSB is always the first PCM bit shifted in or out of: ST5090.

**Transmit/Receive enabling/disabling**

Bit 'EN' (2) enables or disables voice data transfer on D<sub>x</sub> and D<sub>R</sub> pins. When disabled, PCM data from D<sub>R</sub> is not decoded and PCM time-slots are high impedance on D<sub>x</sub>. Default value is disabled.

**B-channel selection (1)**

Bit TS(1) permits selection between B1 or B2 channels. Default value is B1 channel.

**Supply Voltage selection**

Bit SV (0) permits selection of the power supply of the ST5090. Default value is 3.3V.

**CONTROL REGISTER CR2 (1)**

Data sent to receive path or data received from D<sub>R</sub> input. Refer to bit MR(4) in "Control Register CR1" paragraph.

**CONTROL REGISTER CR3 (1)**

D<sub>x</sub> data transmitted. Refer to bit MX(3) in "Control Register CR1" paragraph.

**CONTROL REGISTER CR4**

First byte of a READ or a WRITE instruction to Control Register CR4 is as shown in TABLE 1. Second byte is as shown in TABLE 6.

**Transmit Input Selection**

MIC1 or MIC2 or MIC3 or transmit mute can be selected with bits 6 and 7 (V<sub>s</sub> and TE). Transmit gain can be adjusted within a 22.5 dB range in 1.5 dB step with Register CR5.

**Sidetone Selection**

Bit "SI" (5) enables or disables Sidetone circuitry. When enabled, sidetone gain can be adjusted with Register (CR5). When Transmit path is disabled, sidetone circuit is also disabled.

**Output Driver Selection**

Bits OE1(4) and OE2(3) provide the selection among the earpiece output or the extra amplifier output or both outputs muted. OE1 = 1 and OE2 = 1 is not allowed.

**Ring/Tone signal selection**

Bit RTE (2) provide select capability to connect on-chip Ring/Tone generator either to an extra amplifier input or to earpiece amplifier input.

**PCM receive data selection**

Bits "SE" (0) provide select capability to connect received speech signal either to an extra amplifier input or to earpiece amplifier input.

**CONTROL REGISTER CR5**

First byte of a READ or a WRITE instruction to Control Register CR5 is as shown in TABLE 1. Second byte is as shown in TABLE 7.

**Transmit gain selection**

Transmit amplifier can be programmed for a gain from 0dB to 22.5dB in 1.5dB step with bits 4 to 7. 0 dBmO level at the output of the transmit amplifier (A reference point) is 0.492 V<sub>rms</sub> (overload voltage is 0.707 V<sub>rms</sub>).

**Sidetone attenuation selection**

Transmit signal picked up after the switched capacitor low pass filter may be fed back into both Receive amplifiers.

Attenuation of the signal at the output of the sidetone attenuator can be programmed from -12.5dB to -27.5dB relative to reference point A in 1 dB step with bits 0 to 3.

**CONTROL REGISTER CR6**

First byte of a READ or a WRITE instruction to Control Register CR6 is as shown in TABLE 1. Second byte is as shown in TABLE 8.

**Earpiece amplifier gain selection:**

Earpiece Receive gain can be programmed in 2 dB step from 0 dB to -30 dB relative to the maximum with bits 4 to 7.

0 dBmO voltage at the output of the amplifier on pins V<sub>F+</sub> and V<sub>F-</sub> is then 1.965 V<sub>rms</sub> when 0dB gain is selected down to 61.85 V<sub>rms</sub> when -30dB gain is selected.

**Extra amplifier gain selection:**

Extra Receive amplifier gain can be programmed in 2 dB step from 0 dB to -30 dB relative to the maximum with bits 0 to 3.

0 dBmO voltage on the output of the amplifier on pins V<sub>L+</sub> and V<sub>L-</sub> 1.965 V<sub>rms</sub> when 0 dB gain is selected down to 61.85 mV<sub>rms</sub> when -30 dB gain is selected.

**CONTROL REGISTER CR7:**

First byte of a READ or a WRITE instruction to Control Register CR7 is as shown in TABLE 1. Second byte is as shown in TABLE 9.

(1) Significant in companded mode only

**Tone/Ring amplifier gain selection**

Output level of Ring/Tone generator, before attenuation by programmable attenuator is 1.6 Vpk-pk when f1 generator is selected alone or summed with the f2 generator and 1.26 Vpk-pk when f2 generator is selected alone.

Selected output level can be attenuated down to -27 dB by programmable attenuator by setting bits 4 to 7.

**Frequency mode selection**

Bits 'F1' (3) and 'F2' (2) permit selection of f1 and/or f2 frequency generator according to TABLE 9.

When f1 (or f2) is selected, output of the Ring/Tone is a squarewave (or a sinewave) signal at the frequency selected in the CR8 (or CR9) Register.

When f1 and f2 are selected in summed mode, output of the Ring/Tone generator is a signal where f1 and f2 frequency are summed.

In order to meet DTMF specifications, f2 output level is attenuated by 2dB relative to the f1 output level.

Frequency temporization must be controlled by the microcontroller.

**Waveform selection**

Bit 'SN' (1) selects waveform of the output of the Ring/Tone generator. Sinewave or squarewave signal can be selected.

**DTMF selection**

Bit DE (0) permits connection of Ring/Tone/DTMF generator on the Transmit Data path instead of the Transmit Amplifier output. Earpiece or extra receive output feed-back may be provided by sidetone circuitry by setting bit SI or directly by setting bit RTE in Register CR4. Loudspeaker feed-back may be provided directly by setting bit RTL in Register CR4.

**CONTROL REGISTERS CR8 AND CR9**

First byte of a READ or a WRITE instruction to Control Register CR8 or CR9 is as shown in TABLE 1. Second byte is respectively as shown in TABLE 10 and 11.

If "standard frequency tone range" is selected, Tone or Ring signal frequency value is defined by the formula:

$$f1 = CR8 / 0.128 \text{ Hz}$$

and

$$f2 = CR9 / 0.128 \text{ Hz}$$

where CR8 and CR9 are decimal equivalents of the binary values of the CR8 and CR9 registers

respectively. Thus, any frequency between 7.8 Hz and 1992 Hz may be selected in 7.8 Hz step.

If "halved frequency tone range" is selected, Tone or Ring signal frequency value is defined by the formula:

$$f1 = CR8 / 0.256 \text{ Hz}$$

and

$$f2 = CR9 / 0.256 \text{ Hz}$$

This any frequency between 3.9Hz and 996Hz may be selected in 3.9Hz step.

If "doubled frequency tone range" is selected, Tone or Ring signal frequency value is defined by the formula:

$$f1 = CR8 / 0.064 \text{ Hz}$$

and

$$f2 = CR9 / 0.064 \text{ Hz}$$

Thus any frequency between 15.6Hz and 3984Hz may be selected in 15.6Hz step.

TABLE 12 gives examples for the main frequencies usual for Tone or Ring generation.

**CONTROL REGISTER CR10**

Bit DFT(1) and HFT(0) permits the selection among "standard frequency tone range" (i.e. from 7.8Hz to 1992Hz in 7.8Hz step), "halved frequency tone range" (i.e. from 3.9Hz to 996Hz in 3.9Hz step), and "doubled frequency tone range" (i.e. from 15.6Hz to 3984Hz in 15.6Hz step) according to the values described in CONTROL REGISTER CR8 and CR9.

**CONTROL REGISTER CR11**

Bit BE(7) permits connection of a f1 squarewave PWM Ring signal, amplitude modulated or not by a f2 squarewave signal, to buzzer driver output BZ. Bits BZ5 to BZ0 define the duty cycle of the PWM squarewave, according to the following formula:

$$\text{Duty Cycle} = CR11(5 \div 0) \times 0.78125\%$$

where CR11(5 ÷ 0) is the decimal equivalent of the binary value BZ5 ÷ BZ0.

When BE = 1, if bits F1 = 1 and F2 = 0 in register CR7, a f1 PWM ring signal is present at the buzzer output, while if bits F1 = 1 and F2 = 1 in register CR7 the f1 PWM ring signal is also amplitude modulated by a f2 squarewave frequency. Bit BI (6) allows to chose the logic level at which the duty cycle is referred: BI = 0 means that duty cycle is intended as the relative width of the logic1, while BI = 1 means that duty cycle is intended as the relative width of the logic 0. When BE = 0 (or during power down) BZ = 0 if BI = 0 or BZ = 1 if BI = 1.

**Table 12:** Examples of Usual Frequency Selection (Standard frequency tone range)

Description	f1 value (decimal)	Theoretic value (Hz)	Typical value (Hz)	Error %
Tone 250 Hz	32	250	250	.00
Tone 330 Hz	42	330	328.2	-.56
Tone 425 Hz	54	425	421.9	-.73
Tone 440 Hz	56	440	437.5	-.56
Tone 800 Hz	102	800	796.9	-.39
Tone 1330 Hz	170	1330	1328.1	-.14
DTMF 697 Hz	89	697	695.3	-.24
DTMF 770 Hz	99	770	773.4	+.44
DTMF 852 Hz	109	852	851.6	-.05
DTMF 941 Hz	120	941	937.5	-.37
DTMF 1209 Hz	155	1209	1210.9	+.16
DTMF 1336 Hz	171	1336	1335.9	-.01
DTMF 1477 Hz	189	1477	1476.6	.00
DTMF 1633 Hz	209	1633	1632.8	.00
SOL	50	392	390.6	-.30
LA	56	440	437.5	-.56
SI	63	494	492.2	-.34
DO	67	523.25	523.5	+.04
RE	75	587.33	586.0	-.23
MI flat	80	622.25	625.0	+.45
MI	84	659.25	656.3	-.45
FA	89	698.5	695.3	-.45
FA sharp	95	740	742.2	+.30
SOL	100	784	781.3	-.34
SOL sharp	106	830.6	828.2	-.29
LA	113	880	882.9	+.33
SI	126	987.8	984.4	-.34
DO	134	1046.5	1046.9	+.04
RE	150	1174.66	1171.9	-.23
MI	169	1318.5	1320.4	+.14

**TIMING DIAGRAM**

**Non Delayed Data Timing Mode (Normal) (\*)**

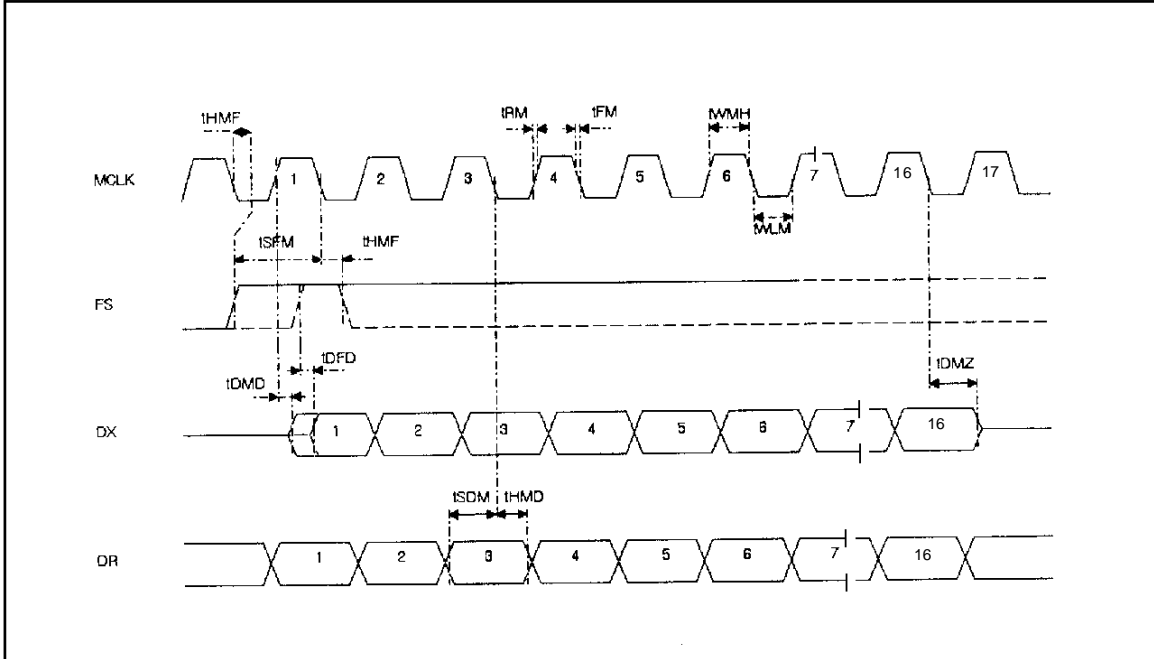

**Delayed Data Timing Mode (\*)**

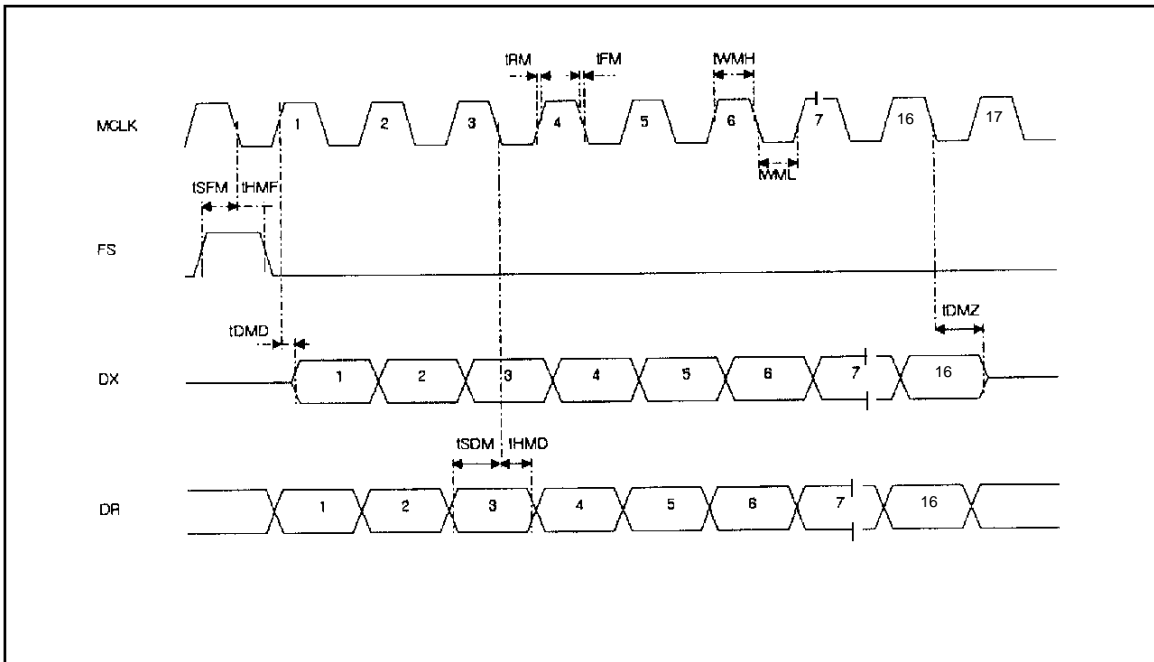

(\*) In the case of companded code the timing is applied to 8 bits instead of 16 bits (see ST5080A data sheet)

TIMING DIAGRAM (continued)

Non Delayed Reverse Data Timing Mode (\*)

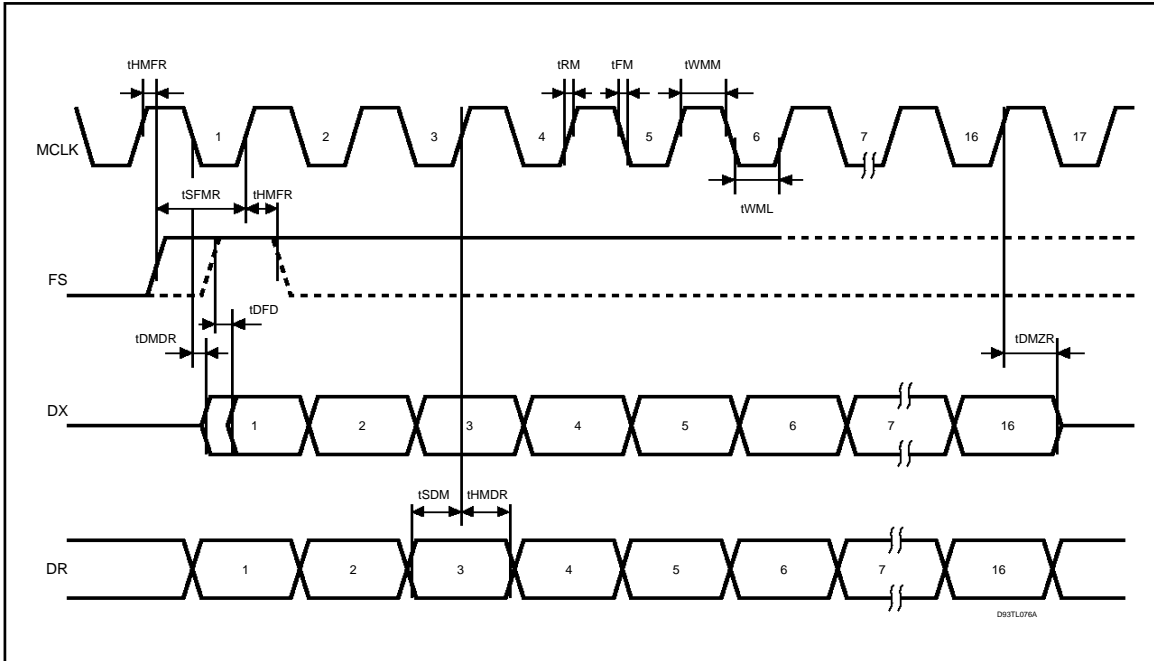

(\*) In the case of companded code the timing is applied to 8 bits instead of 16 bits.

Serial Control Timing (MICROWIRE MODE)

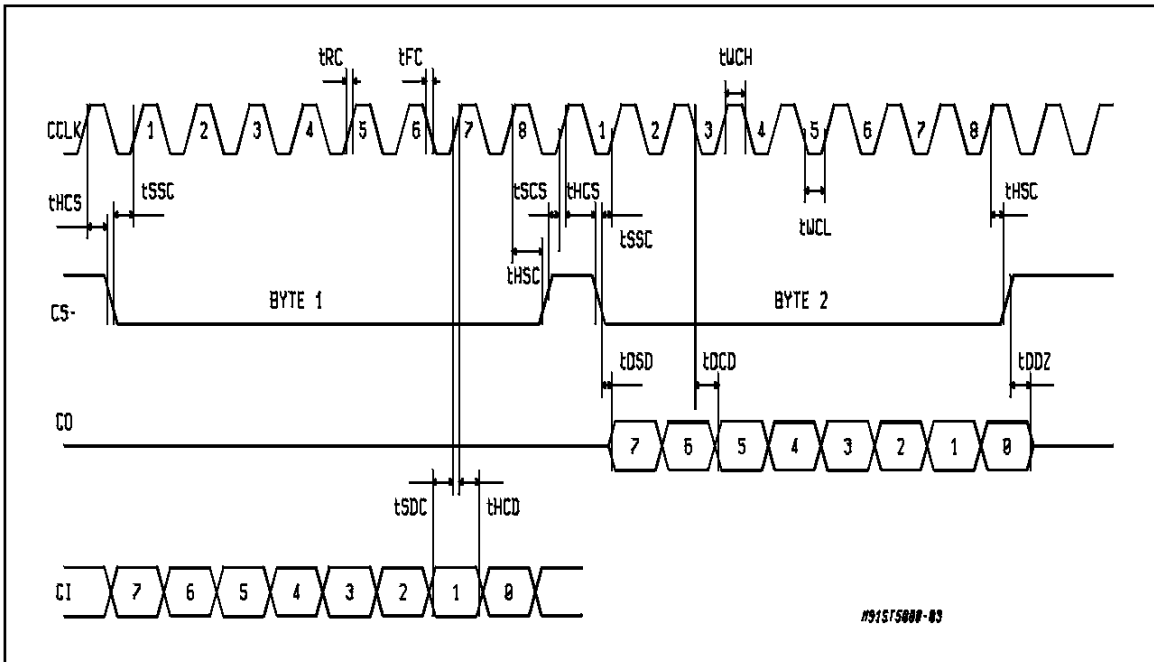

**ABSOLUTE MAXIMUM RATINGS**

Parameter	Value	Unit
V <sub>CC</sub> to GND	7	V
Voltage at MIC (V <sub>CC</sub> ≤ 5.5V)	V <sub>CC</sub> +1 to GND -1	V
Current at V <sub>Fr</sub> and V <sub>Lr</sub>	± 100	mA
Current at any digital output	± 50	mA
Voltage at any digital input (V <sub>CC</sub> ≤ 5.5V); limited at ± 50mA	V <sub>CC</sub> + 1 to GND - 1	V
Storage temperature range	- 65 to + 150	°C
Lead Temperature (wave soldering, 10s)	+ 260	°C

**TIMING SPECIFICATIONS** (unless otherwise specified, V<sub>CC</sub> = 3.3V ± 10% or 5V ± 10%, T<sub>A</sub> = -30°C to 85°C ; typical characteristics are specified V<sub>CC</sub> = 3.3V, T<sub>A</sub> = 25 °C ; all signals are referenced to GND, see Note 5 for timing definitions)

NOTICE: All timing specifications can be changed.

**MASTER CLOCK TIMING**

Symbol	Parameter	Test Condition	Min.	Typ.	Max.	Unit
f <sub>MCLK</sub>	Frequency of MCLK	Selection of frequency is programmable (see table 2)		512 1.536 2.048 2.560		kHz MHz MHz MHz
t <sub>WMH</sub>	Period of MCLK high	Measured from V <sub>IH</sub> to V <sub>IH</sub>	80			ns
t <sub>WML</sub>	Period of MCLK low	Measured from V <sub>IL</sub> to V <sub>IL</sub>	80			ns
t <sub>RM</sub>	Rise Time of MCLK	Measured from V <sub>IL</sub> to V <sub>IH</sub>			30	ns
t <sub>FM</sub>	Fall Time of MCLK	Measured from V <sub>IH</sub> to V <sub>IL</sub>			30	ns

**PCM INTERFACE TIMING**

Symbol	Parameter	Test Condition	Min.	Typ.	Max.	Unit
t <sub>HMF</sub>	Hold Time MCLK low to FS low		0			ns
t <sub>SFM</sub>	Setup Time, FS high to MCLK low		30			ns
t <sub>DMD</sub>	Delay Time, MCLK high to data valid	Load = 100 pf			100	ns
t <sub>DMZ</sub>	Delay Time, MCLK low to DX disabled		10		100	ns
t <sub>DFD</sub>	Delay Time, FS high to data valid	Load = 100 pf ; Applies only if FS rises later than MCLK rising edge in Non Delayed Mode only			100	ns
t <sub>SDM</sub>	Setup Time, D <sub>R</sub> valid to MCLK receive edge		20			ns
t <sub>HMD</sub>	Hold Time, MCLK low to D <sub>R</sub> invalid		10			ns
t <sub>HMFR</sub>	Hold Time MCLK High to FS low		30			ns
t <sub>SFMR</sub>	Setup Time, FS high to MCLK High		30			ns
t <sub>DMDR</sub>	Delay Time, MCLK low to data valid	Load = 100pF			100	ns
t <sub>DMZR</sub>	Delay Time, MCLK High to DX disabled		10		100	ns
t <sub>HMDR</sub>	Hold Time, MCLK High to D <sub>R</sub> invalid		20			ns

**SERIAL CONTROL PORT TIMING**

Symbol	Parameter	Test Condition	Min.	Typ.	Max.	Unit
f <sub>CCLK</sub>	Frequency of CCLK				2.048	MHz
t <sub>WCH</sub>	Period of CCLK high	Measured from V <sub>IH</sub> to V <sub>IH</sub>	160			ns
t <sub>WCL</sub>	Period of CCLK low	Measured from V <sub>IL</sub> to V <sub>IL</sub>	160			ns
t <sub>RC</sub>	Rise Time of CCLK	Measured from V <sub>IL</sub> to V <sub>IH</sub>			50	ns
t <sub>FC</sub>	Fall Time of CCLK	Measured from V <sub>IH</sub> to V <sub>IL</sub>			50	ns
t <sub>HCS</sub>	Hold Time, CCLK high to CS- low		10			ns
t <sub>SSC</sub>	Setup Time, CS- low to CCLK high		50			ns
t <sub>SDC</sub>	Setup Time, CI valid to CCLK high		50			ns
t <sub>HCD</sub>	Hold Time, CCLK high to CI invalid		50			ns
t <sub>DCD</sub>	Delay Time, CCLK low to CO data valid	Load = 100 pF			80	ns
t <sub>DSD</sub>	Delay Time, CS-low to CO data valid				50	ns
t <sub>DDZ</sub>	Delay Time CS-high or 8th CCLK low to CO high impedance whichever comes first		10		80	ns
t <sub>HSC</sub>	Hold Time, 8th CCLK high to CS- high		100			ns
t <sub>SCS</sub>	Setup Time, CS- high to CCLK high		100			ns

Note 5: A signal is valid if it is above V<sub>IH</sub> or below V<sub>IL</sub> and invalid if it is between V<sub>IL</sub> and V<sub>IH</sub>. For the purposes of this specification the following conditions apply:  
 a) All input signal are defined as: V<sub>IL</sub> = 0.2V<sub>CC</sub>, V<sub>IH</sub> = 0.8V<sub>CC</sub>, t<sub>r</sub> < 10ns, t<sub>f</sub> < 10ns.  
 b) Delay times are measured from the inputs signal valid to the output signal valid.  
 c) Setup times are measured from the data input valid to the clock input invalid.  
 d) Hold times are measured from the clock signal valid to the data input invalid.

**ELECTRICAL CHARACTERISTICS** (unless otherwise specified, V<sub>CC</sub> = 3.3V ± 10% or 5V ± 10%, T<sub>A</sub> = -30°C to 85°C ; typical characteristic are specified at V<sub>CC</sub> = 3.3V, T<sub>A</sub> = 25°C ; all signals are referenced to GND)

**DIGITAL INTERFACES**

Symbol	Parameter	Test Condition	Min.	Typ.	Max.	Unit
V <sub>IL</sub>	Input Low Voltage	DC			0.3V <sub>CC</sub>	V
		AC			0.2V <sub>CC</sub>	V
V <sub>IH</sub>	Input High Voltage	DC	0.7V <sub>CC</sub>			V
		AC	0.8V <sub>CC</sub>			V
V <sub>OL</sub>	Output Low Voltage	All digital outputs, I <sub>L</sub> = 10µA			0.1	V
		All digital outputs, I <sub>L</sub> = 2mA			0.4	V
V <sub>OH</sub>	Output High Voltage	All digital outputs, I <sub>L</sub> = 10µA	V <sub>CC</sub> -0.1			V
		All digital outputs, I <sub>L</sub> = 2mA	V <sub>CC</sub> -0.4			V
I <sub>IL</sub>	Input Low Current	Any digital input, GND < V <sub>IN</sub> < V <sub>IL</sub>	-10		10	µA
I <sub>IH</sub>	Input High Current	Any digital input, V <sub>IH</sub> < V <sub>IN</sub> < V <sub>CC</sub>	-10		10	µA
I <sub>OZ</sub>	Output Current in High impedance (Tri-state)	D <sub>X</sub> and CO	-10		10	µA

**A.C. TESTING INPUT, OUTPUT WAVEFORM**

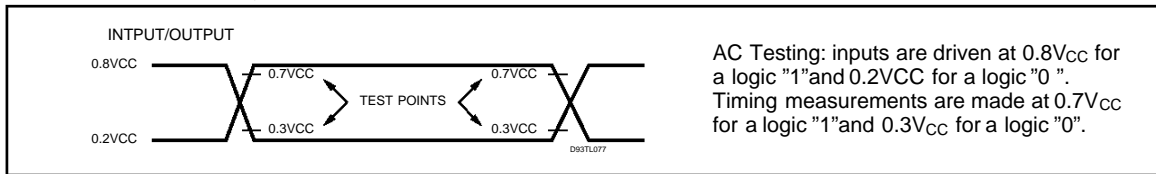

## ANALOG INTERFACES

Symbol	Parameter	Test Condition	Min.	Typ.	Max.	Unit
$I_{MIC}$	Input Leakage	$GND < V_{MIC} < V_{CC}$	-100		+100	$\mu A$
$R_{MIC}$	Input Resistance	$GND < V_{MIC} < V_{CC}$	50			$k\Omega$
$R_{LVFr}$	Load Resistance (*)	$V_{Fr+}$ to $V_{Fr-}$	30			$\Omega$
$C_{LVFr}$	Load Capacitance (*)	From $V_{Fr+}$ to $V_{Fr-}$		50		nF
$R_{OVFr0}$	Output Resistance	Steady zero PCM code applied to DR; $I = \pm 1mA$		1.0		$\Omega$
$V_{OSVFr0}$	Differential offset: Voltage at $V_{Fr+}$ , $V_{Fr-}$	Alternating $\pm$ zero PCM code applied to DR maximum receive gain; $R_L = 100\Omega$	-100		+100	mV
$R_{LVFr}$	Load Resistance (*)	$V_{Lr+}$ to $V_{Lr-}$	30			$\Omega$
$C_{LVFr}$	Load Capacitance (*)	from $V_{Lr+}$ to $V_{Lr-}$		50		nF
$R_{OLVr0}$	Output Resistance	Steady zero PCM code applied to DR; $I = \pm 1mA$		1		$\Omega$
$V_{OSVr0}$	Differential offset Voltage at $V_{Lr+}$ , $V_{Lr-}$	Alternating $\pm$ zero PCM code applied to DR maximum receive gain; $R_L = 50\Omega$	-100		+100	mV

(\*) See application note for  $V_{Fr}$  and  $V_{Lr}$  connections.

## POWER DISSIPATION

Symbol	Parameter	Test Condition	Min.	Typ.	Max.	Unit
$I_{CC0}$	Power down Current at $3.3V \pm 10\%$	$CCLK, CI = 0.1V; CS = V_{CC} - 0.1V$		0.5	5	$\mu A$
$I_{CC0}$	Power down Current at $5V \pm 10\%$	$CCLK, CI = 0.1V; CS = V_{CC} - 0.1V$		1	10	$\mu A$
$I_{CC1}$	Power Up Current at $3.3V \pm 10\%$	$V_{Lr+}$ , $V_{Lr-}$ and $V_{Fr+}$ , $V_{Fr-}$ not loaded		7	10	mA
$I_{CC1}$	Power Up Current at $5V \pm 10\%$	$V_{Lr+}$ , $V_{Lr-}$ and $V_{Fr+}$ , $V_{Fr-}$ not loaded		8	12	mA

**TRANSMISSION CHARACTERISTICS** (unless otherwise specified,  $V_{CC} = 3.3V \pm 10\%$  or  $5V \pm 10\%$ ,  $T_A = -30^\circ C$  to  $85^\circ C$ ; typical characteristics are specified at  $V_{CC} = 3.3V$ ,  $T_A = 25^\circ C$ ,  $MIC1/2/3 = 0dBm0$ ,  $DR = -6dBm0$  PCM code,  $f = 1015.625$  Hz; all signal are referenced to GND)

**AMPLITUDE RESPONSE** (Maximum, Nominal, and Minimum Levels)

Transmit path - Absolute levels at MIC1 / MIC2 / MIC3

Parameter	Test Condition	Min.	Typ.	Max.	Unit
0 dBm0 level	Transmit Amps connected for 20dB gain		49.26		mV <sub>RMS</sub>
Overload level			70.71		mV <sub>RMS</sub>
0 dBm0 level	Transmit Amps connected for 42.5dB gain		3.694		mV <sub>RMS</sub>
Overload level			5.302		mV <sub>RMS</sub>

**TRANSMISSION CHARACTERISTICS** (continued)**AMPLITUDE RESPONSE** (Maximum, Nominal, and Minimum Levels)Receive path - Absolute levels at  $V_{FR}$  (Differentially measured)

Parameter	Test Condition	Min.	Typ.	Max.	Unit
0 dBm0 level	Receive Amp programmed for 0dB gain		1.965		$V_{RMS}$
0 dBm0 level	Receive Amp programmed for - 30dB attenuation		61.85		$mV_{RMS}$

**AMPLITUDE RESPONSE** (Maximum, Nominal, and Minimum Levels)Receive path - Absolute levels at  $V_{Lr}$  (Differentially measured)

Parameter	Test Condition	Min.	Typ.	Max.	Unit
0 dBm0 level	Receive Amp programmed for 0dB gain		1.965		$V_{RMS}$
0 dBm0 level	Receive Amp programmed for - 30dB gain		61.85		$mV_{RMS}$

**AMPLITUDE RESPONSE**

Transmit path

Symbol	Parameter	Test Condition	Min.	Typ.	Max.	Unit
$G_{XA}$	Transmit Gain Absolute Accuracy	Transmit Gain Programmed for maximum. Measure deviation of Digital PCM Code from ideal 0dB <sub>m0</sub> PCM code at $D_x$	-0.5		0.5	dB
$G_{XAG}$	Transmit Gain Variation with programmed gain	Measure Transmit Gain over the range from Maximum to minimum setting. Calculate the deviation from the programmed gain relative to $G_{XA}$ , i.e. $G_{XAG} = G_{actual} - G_{prog.} - G_{XA}$	-0.5		0.5	dB
$G_{XAT}$	Transmit Gain Variation with temperature	Measured relative to $G_{XA}$ . min. gain < $G_x$ < Max. gain	-0.1		0.1	dB
$G_{XAV}$	Transmit Gain Variation with supply	Measured relative to $G_{XA}$ $G_x$ = Maximum gain	-0.1		0.1	dB
$G_{XAF}$	Transmit Gain Variation with frequency	Relative to 1015,625 Hz, multitone test technique used. min. gain < $G_x$ < Max. gain f = 60 Hz f = 100 Hz f = 200 Hz f = 300 Hz f = 400 Hz to 3000 Hz f = 3400 Hz f = 4000 Hz f = 4600 Hz (*) f = 8000 Hz (*)	-1.5 -0.5 -1.5		-30 -20 -6 0.5 0.5 0.0 -14 -35 -47	dB dB dB dB dB dB dB dB
$G_{XAL}$	Transmit Gain Variation with signal level	Sinusoidal Test method. Reference Level = -10 dBm0 $V_{MIC} = -40$ dBm0 to +3 dBm0 $V_{MIC} = -50$ dBm0 to -40 dBm0 $V_{MIC} = -55$ dBm0 to -50 dBm0	-0.5 -0.5 -1.2		0.5 0.5 1.2	dB dB dB

(\*) The limit at frequencies between 4600Hz and 8000Hz lies on a straight line connecting the two frequencies on a linear (dB) scale versus log (Hz) scale.

**AMPLITUDE RESPONSE**

Receive path

Symbol	Parameter	Test Condition	Min.	Typ.	Max.	Unit
G <sub>RAE</sub>	Receive Gain Absolute Accuracy	Receive gain programmed for maximum Apply -6 dB <sub>m0</sub> PCM code to D <sub>R</sub> Measure V <sub>F<sub>r</sub>+</sub>	-0.5		0.5	dB
G <sub>RAL</sub>	Receive Gain Absolute Accuracy	Receive gain programmed for maximum Apply -6 dB <sub>m0</sub> PCM code to D <sub>R</sub> Measure V <sub>L<sub>r</sub>+</sub>	-0.5		0.5	dB
G <sub>RAGE</sub>	Receive Gain Variation with programmed gain	Measure V <sub>F<sub>r</sub></sub> Gain over the range from Maximum to minimum setting. Calculate the deviation from the programmed gain relative to G <sub>RAE</sub> , i.e. $G_{RAGE} = G_{actual} - G_{prog.} - G_{RAE}$	-0.5		0.5	dB
G <sub>RAGL</sub>	Receive Gain Variation with programmed gain	Measure V <sub>L<sub>r</sub></sub> Gain over the range from Maximum to minimum setting. Calculate the deviation from the programmed gain relative to G <sub>RAL</sub> , i.e. $G_{RAGL} = G_{actual} - G_{prog.} - G_{RAL}$	-0.5		0.5	dB
G <sub>RAT</sub>	Receive Gain Variation with temperature	Measured relative to G <sub>RA</sub> . (V <sub>L<sub>r</sub></sub> and V <sub>F<sub>r</sub></sub> ) min. gain < G <sub>R</sub> < Max. gain	-0.1		0.1	dB
G <sub>RAV</sub>	Receive Gain Variation with Supply	Measured relative to G <sub>RA</sub> . (V <sub>L<sub>r</sub></sub> and V <sub>F<sub>r</sub></sub> ) G <sub>R</sub> = Maximum Gain	-0.1		0.1	dB
G <sub>RAF</sub>	Receive Gain Variation with frequency (V <sub>L<sub>r</sub></sub> and V <sub>F<sub>r</sub></sub> )	Relative to 1015,625 Hz, multitone test technique used. min. gain < G <sub>R</sub> < Max. gain f = 60Hz f = 100Hz f = 200 Hz f = 300 Hz f = 400 Hz to 3000 Hz f = 3400 Hz f = 4000 Hz	-1.5 -0.5 -1.5		-20 -12 -2 0.5 0.5 0.0 -14	dB dB dB dB dB dB dB
G <sub>RALE</sub>	Receive Gain Variation with signal level (V <sub>F<sub>r</sub></sub> )	Sinusoidal Test Method Reference Level = -10 dBm0 D <sub>R</sub> = -40 dBm0 to -3 dBm0 D <sub>R</sub> = -50 dBm0 to -40 dBm0 D <sub>R</sub> = -55 dBm0 to -50 dBm0	-0.5 -0.5 -1.2		0.5 0.5 1.2	dB dB dB
G <sub>RALL</sub>	Receive Gain Variation with signal level (V <sub>L<sub>r</sub></sub> )	Sinusoidal Test Method Reference Level = -10 dBm0 D <sub>R</sub> = -40 dBm0 to -3 dBm0 D <sub>R</sub> = -50 dBm0 to -40 dBm0 D <sub>R</sub> = -55 dBm0 to -50 dBm0	-0.5 -0.5 -1.2		0.5 0.5 1.2	dB dB dB

## ENVELOPE DELAY DISTORTION WITH FREQUENCY

Symbol	Parameter	Test Condition	Min.	Typ.	Max.	Unit
DXA	Tx Delay, Absolute	f = 1600 Hz		320		μs
DXR	Tx Delay, Relative	f = 500 - 600 Hz		290		μs
		f = 600 - 800 Hz		180		μs
		f = 800 - 1000 Hz		50		μs
		f = 1000 - 1600 Hz		20		μs
		f = 1600 - 2600 Hz		55		μs
		f = 2600 - 2800 Hz		80		μs
DRA	Rx Delay, Absolute	f = 1600 Hz		280		μs
DRR	Rx Delay, Relative	f = 500 - 600 Hz		200		μs
		f = 600 - 800 Hz		110		μs
		f = 800 - 1000 Hz		50		μs
		f = 1000 - 1600 Hz		20		μs
		f = 1600 - 2600 Hz		65		μs
		f = 2600 - 2800 Hz		100		μs
		f = 2800 - 3000 Hz		220		μs

## NOISE

Symbol	Parameter	Test Condition	Min.	Typ.	Max.	Unit
NXP	Tx Noise, P weighted (up to 35dB)	V <sub>MIC</sub> = 0V, DE = 0		-75	-70	dBm0p
NRP	Rx Noise, A weighted (max. gain)	Receive PCM code = Positive Zero SI = 0 and RTE = 0		120	150	μVrms (*)
NRS	Noise, Single Frequency	MIC = 0V, Loop-around measurement from f = 0 Hz to 100 kHz		-50		dBm0
PPSRx	PSRR, Tx	MIC = 0V, V <sub>CC</sub> = 3.3 V <sub>DC</sub> + 50 mV <sub>rms</sub> ; f = 0Hz to 50KHz	30	60		dB
PPSRp	PSRR, Rx	PCM Code equals Positive Zero, V <sub>CC</sub> = 3.3 VDC + 50 mVrms, f = 0 Hz - 4 kHz f = 4 kHz - 50 kHz	30	70		dB
			30	70		dB
SOS	Spurious Out-Band signal at the output	DR input set to -6 dBm0 PCM code 300 - 3400 Hz Input PCM Code applied at DR 4600 Hz - 5600 Hz 5600 Hz - 7600 Hz 7600 Hz - 8400 Hz				
					-40	dB
					-50	dB
					-50	dB

(\*) A Weighted

## DISTORTION

Symbol	Parameter	Test Condition	Min.	Typ.	Max.	Unit
S <sub>TDX</sub> (*)	Signal to Total Distortion (up to 35dB gain)  Typical values are measured with 30.5dB gain	Sinusoidal Test Method (measured using linear 300 to 3400 weighting)		#		
		Level = 0 dBm0	56	56	65	dB
		Level = -6 dBm0	50	50	64	dB
		Level = -10 dBm0	48	48	61	dB
		Level = -20 dBm0	43	43	52	dB
		Level = -30 dBm0	38	37.5	42	dB
		Level = -40 dBm0	29	28.5	31	dB
		Level = -45 dBm0	24	23	26	dB
S <sub>DFx</sub>	Single Frequency Distortion transmit	0 dBm0 input signal		-80	-56	dB
S <sub>TDRE</sub> (*)	Signal to Total Distortion (V <sub>Fr</sub> ) ( up to 20dB attenuation)  Typical values are measured with 20dB attenuation.	Sinusoidal Test Method (measured using linear 300 to 3400 weighting)				
		Level = -6 dBm0	50	64	dB	
		Level = -10 dBm0	48	62	dB	
		Level = -20 dBm0	43	53	dB	
		Level = -30 dBm0	38	43	dB	
		Level = -40 dBm0	29	33	dB	
		Level = -45 dBm0	24	28	dB	
		Level = -55 dBm0	15	18	dB	
S <sub>DFr</sub>	Single Frequency Distortion receive (V <sub>Fr</sub> )	-6 dBm0 input signal		-80	-50	dB
S <sub>TDRL</sub> (*)	Signal to Total Distortion (V <sub>Lr</sub> ) (up to 20dB attenuation)  Typical values are measured with 20dB attenuation	Sinusoidal Test Method (measured using linear 300 to 3400 weighting)				
		Level = -6 dBm0	50	64	dB	
		Level = -10 dBm0	48	62	dB	
		Level = -20 dBm0	43	53	dB	
		Level = -30 dBm0	38	43	dB	
		Level = -40 dBm0	29	33	dB	
		Level = -45 dBm0	24	28	dB	
		Level = -55 dBm0	15	18	dB	
S <sub>DLr</sub>	Single Frequency Distortion receive (V <sub>Lr</sub> )	-6 dBm0 input signal		-80	-50	dB
IMD	Intermodulation	Loop-around measurement Voltage at MIC = -10 dBm0 to -27 dBm0, 2 Frequencies in the range 300 - 3400 Hz		-75	-46	dB

(\*) The limit curve shall be determined by straight lines joining successive coordinates given in the table.

(#) Lower limits used during the automatic testing to avoid unrealistic yield loss due to  $\pm 2$ dB imprecision of time-limited noise measurements.

## CROSSTALK

Symbol	Parameter	Test Condition	Min.	Typ.	Max.	Unit
C <sub>Tx-r</sub>	Transmit to Receive	Transmit Level = 0 dBm0, f = 300 - 3400 Hz DR = Quiet PCM Code		-100	-65	dB
C <sub>Tr-x</sub>	Receive to Transmit	Receive Level = -6 dBm0, f = 300 - 3400 Hz MIC = 0V		-80	-65	dB

# ST5090

## APPLICATIONS

### Application Note for Microphone Connections

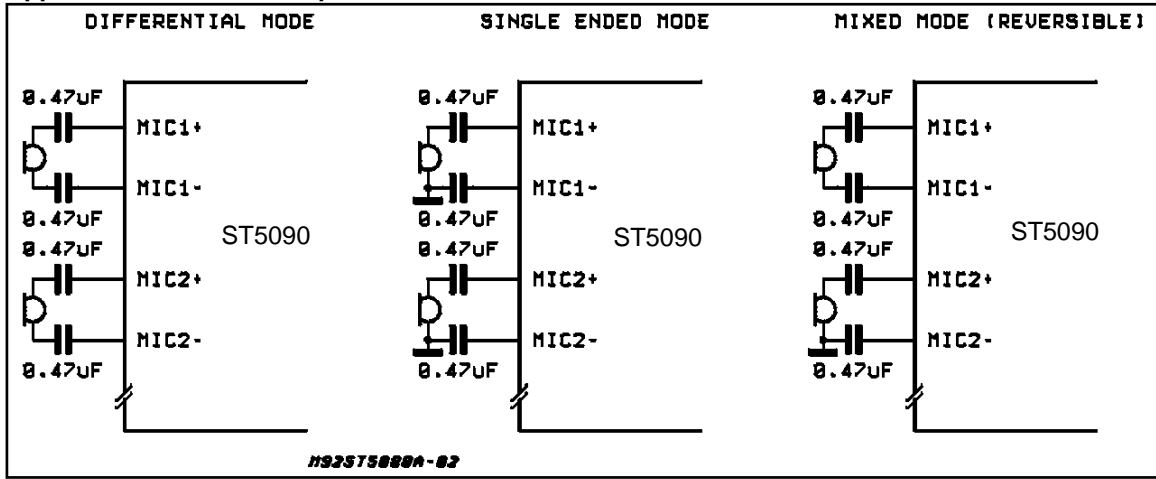

### Application Note for V<sub>Fr</sub> and V<sub>Lr</sub> Connections

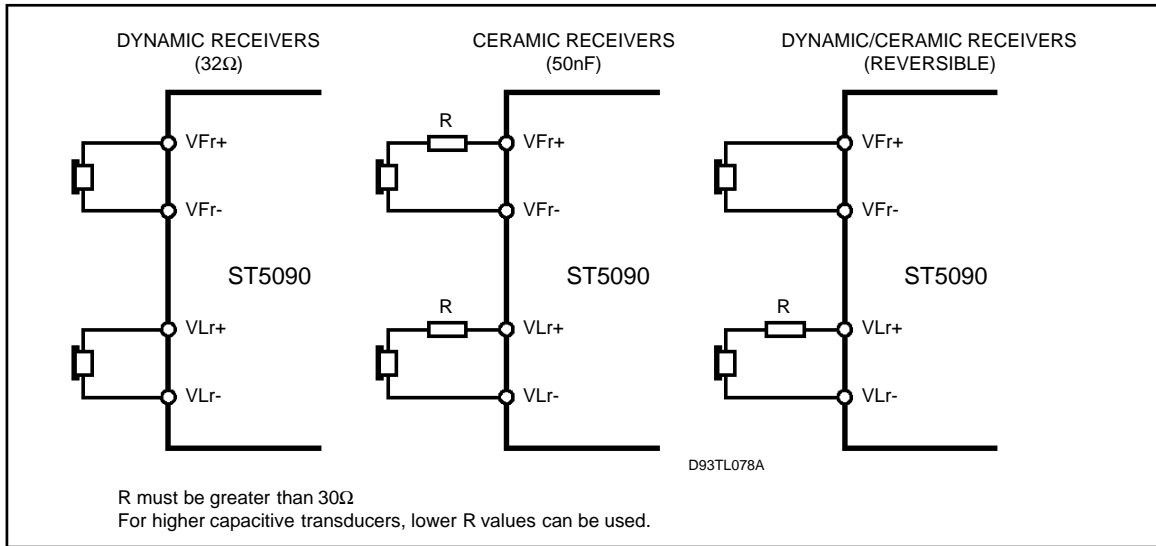

### POWER SUPPLIES

While pins of ST5090 device are well protected against electrical misuse, it is recommended that the standard CMOS practise of applying GND before any other connections are made should always be followed. In applications where the printed circuit card may be plugged into a hot socket with power and clocks already present, an extra long ground pin on the connector should be

used.

To minimize noise sources, all ground connections to each device should meet at a common point as close as possible to the GND pin in order to prevent the interaction of ground return currents flowing through a common bus impedance. A power supply decoupling capacitor of 0.1 μF should be connected from this common point to V<sub>CC</sub> as close as possible to the device pins.

## TQFP44 (10 x 10) PACKAGE MECHANICAL DATA

DIM.	mm			inch		
	MIN.	TYP.	MAX.	MIN.	TYP.	MAX.
A			1.60			0.063
A1	0.05		0.15	0.002		0.006
A2	1.35	1.40	1.45	0.053	0.055	0.057
B	0.30	0.37	0.45	0.012	0.014	0.018
C	0.09		0.20	0.004		0.008
D		12.00			0.472	
D1		10.00			0.394	
D3		8.00			0.315	
e		0.80			0.031	
E		12.00			0.472	
E1		10.00			0.394	
E3		8.00			0.315	
L	0.45	0.60	0.75	0.018	0.024	0.030
L1		1.00			0.039	
K	0°(min.), 3.5°(typ.), 7°(max.)					

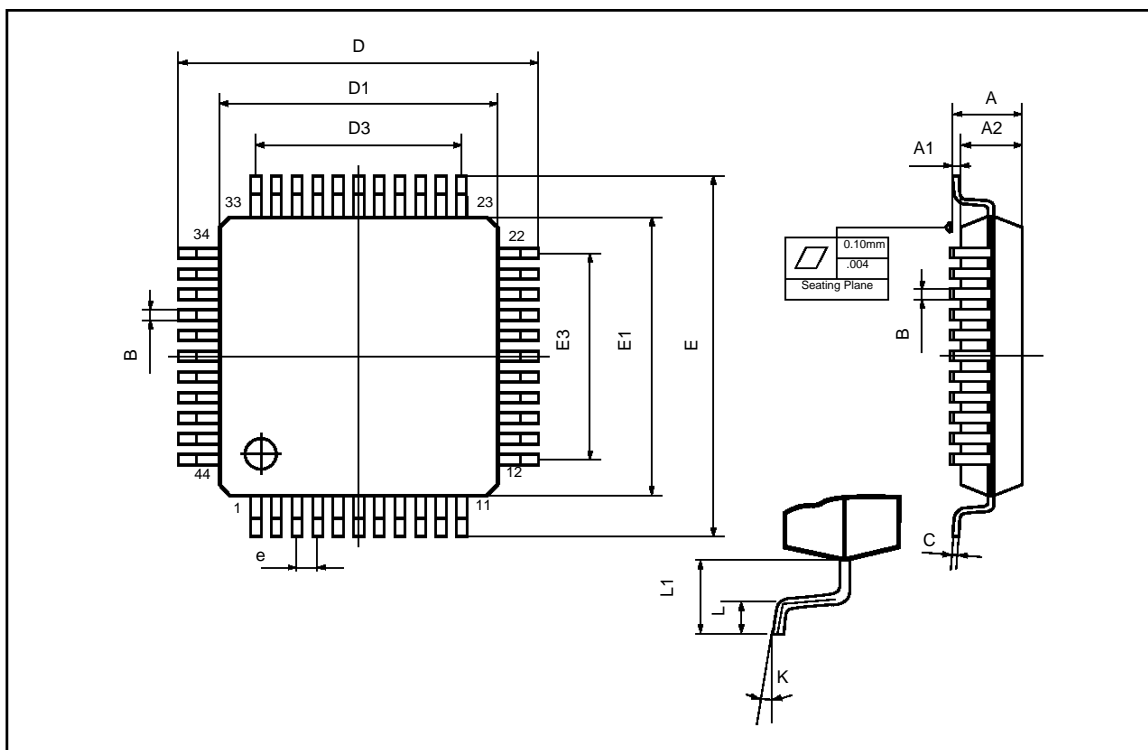

SO28 PACKAGE AND MECHANICAL DATA

DIM.	mm			inch		
	MIN.	TYP.	MAX.	MIN.	TYP.	MAX.
A			2.65			0.104
a1	0.1		0.3	0.004		0.012
b	0.35		0.49	0.014		0.019
b1	0.23		0.32	0.009		0.013
C		0.5			0.020	
c1	45° (typ.)					
D	17.7		18.1	0.697		0.713
E	10		10.65	0.394		0.419
e		1.27			0.050	
e3		16.51			0.65	
F	7.4		7.6	0.291		0.299
L	0.4		1.27	0.016		0.050
S	8° (max.)					

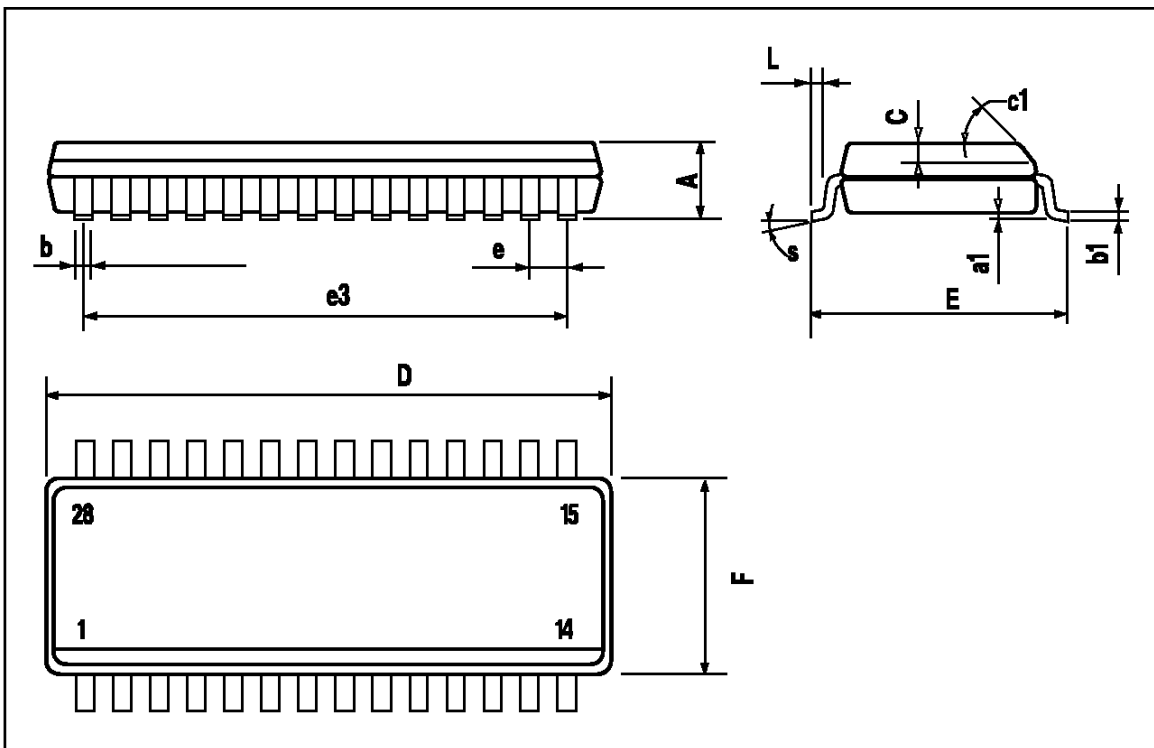

Information furnished is believed to be accurate and reliable. However, SGS-THOMSON Microelectronics assumes no responsibility for the consequences of use of such information nor for any infringement of patents or other rights of third parties which may result from its use. No license is granted by implication or otherwise under any patent or patent rights of SGS-THOMSON Microelectronics. Specifications mentioned in this publication are subject to change without notice. This publication supersedes and replaces all information previously supplied. SGS-THOMSON Microelectronics products are not authorized for use as critical components in life support devices or systems without express written approval of SGS-THOMSON Microelectronics.

© 1996 SGS-THOMSON Microelectronics All Rights Reserved

SGS-THOMSON Microelectronics GROUP OF COMPANIES  
Australia - Brazil - Canada - France - Germany - Hong Kong - Italy - Japan - Korea - Malaysia - Malta - Morocco - The Netherlands  
Singapore - Spain - Sweden - Switzerland - Taiwan - Thailand - United Kingdom - U.S.A.