



STK405-090

AF Power Amplifier (Split Power Supply) (50W + 50W min, THD = 10%)

Overview

The STK405-090, a member of the STK405-000 series, is a low-cost, 2-channel audio power amplifier hybrid IC that is ideal for a wide range of stereo sets. It has dedicated 6Ω output drive, in contrast with the STK401-000 series which supports 6Ω/3Ω output drive.

Features

- Class B amplifiers
- Output load impedance $R_L = 6\Omega$ support
- EIAJ-output compatible (f = 1kHz, THD = 10%)
- Low supply switching shock noise
- Pin assignment grouped into individual blocks of inputs, outputs and supply lines to minimize the adverse effects of pattern layout on operating characteristics
- External bootstrap circuit not necessary
- Standby operation possible using external circuit
- Voltage gain VG = 26dB for easy gain distribution within the set
- Member of 10W/ch to 80W/ch pin-compatible series

Series Organization

The following devices form a series with differing output capacity. Some of the following devices are under development. Contact your Sanyo sales representative if you require more detailed information.

Type No.	Output power	Supply voltage [V]	
		V _{CC} max	V _{CC}
STK405-010	10W + 10W	±26.0	±14.0
STK405-030	20W + 20W	±30.5	±18.5
STK405-050	30W + 30W	±34.5	±22.0
STK405-070	40W + 40W	±39.0	±25.0
STK405-090	50W + 50W	±42.0	±26.5
STK405-100	60W + 60W	±45.0	±29.0
STK405-110	70W + 70W	±50.0	±31.0
STK405-120	80W + 80W	±52.5	±33.0

Package Dimensions

unit: mm

4158

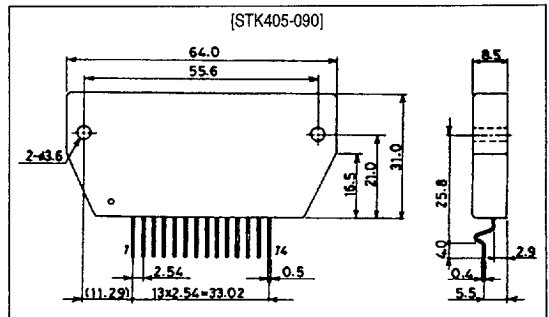

SANYO Electric Co., Ltd. Semiconductor Business Headquarters

TOKYO OFFICE Tokyo Bldg., 1-10, 1 Chome, Ueno, Taito-ku, TOKYO, 110 JAPAN

512

7997076 0021051 106

○1295HA (ID) No. 5180—1/6

Specifications

Maximum Ratings at $T_a = 25^\circ\text{C}$

Parameter	Symbol	Conditions	Ratings	Unit
Maximum supply voltage	$V_{CC \text{ max}}$		± 42	V
Thermal resistance	θ_{j-c}	Per power transistor	2.7	$^\circ\text{C/W}$
Junction temperature	T_j		150	$^\circ\text{C}$
Operating substrate temperature	T_c		125	$^\circ\text{C}$
Storage temperature	T_{stg}		-30 to +125	$^\circ\text{C}$
Available time for load short-circuit	t_s	$V_{CC} = \pm 26.5\text{V}$, $R_L = 6\Omega$, $f = 50\text{Hz}$, $P_O = 50\text{W}$	1	s

Operating Characteristics at $T_a = 25^\circ\text{C}$, $R_L = 6\Omega$ (noninductive load), $R_g = 600\Omega$, $V_G = 26\text{dB}$

Parameter	Symbol	Conditions	min	typ	max	Unit
Quiescent current	I_{CCO}	$V_{CC} = \pm 34.0\text{V}$, no load	-	12	20	mA
Output power	P_O	$V_{CC} = \pm 26.5\text{V}$, $f = 1\text{kHz}$, $\text{THD} = 10.0\%$	50	-	-	W
Total harmonic distortion	THD	$V_{CC} = \pm 26.5\text{V}$, $f = 1\text{kHz}$, $P_O = 5.0\text{W}$	-	0.04	0.1	%
Frequency response	f_L, f_H	$V_{CC} = \pm 26.5\text{V}$, $P_O = 1.0\text{W}$, $+0_{-3}\text{dB}$	-	20 to 50k	-	Hz
Input impedance	r_i	$V_{CC} = \pm 26.5\text{V}$, $f = 1\text{kHz}$, $P_O = 1.0\text{W}$	-	55	-	k Ω
Output noise voltage	V_{NO}	$V_{CC} = \pm 34.0\text{V}$, $R_g = 10\text{k}\Omega$	-	-	1.2	mVrms
Neutral voltage	V_N	$V_{CC} = \pm 34.0\text{V}$	-100	0	+100	mV

Notes.

All tests are measured using a regulated voltage supply unless otherwise specified.

Available time for load short-circuit and output noise voltage are measured using the transformer supply specified below.

The output noise voltage is the peak value of an average-reading meter with an rms value scale (VTVM). A regulated AC supply (50Hz) should be used to eliminate the effects of AC primary line flicker noise.

Specified Transformer Supply (RP-25 or Equivalent)

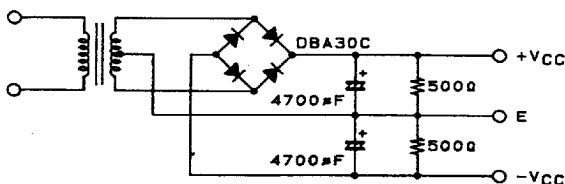

A04153

Block Diagram

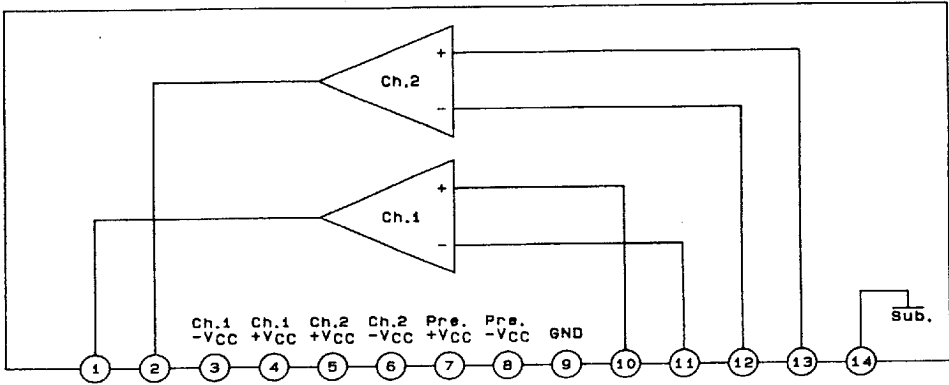

A04184

Test Circuit

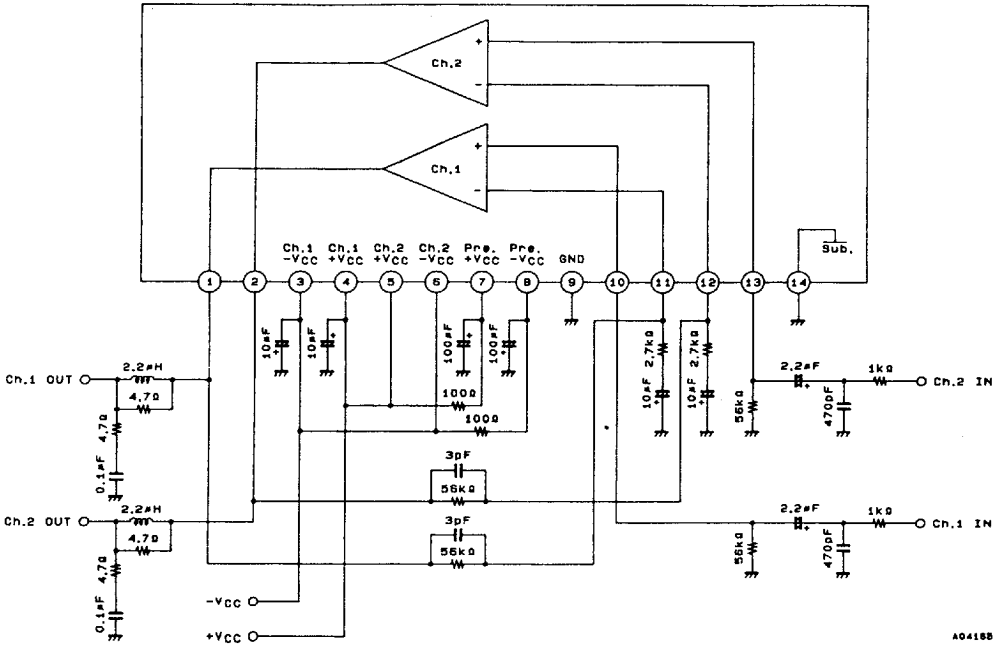

A04188

Sample Application Circuit (Standby Mode Supported)

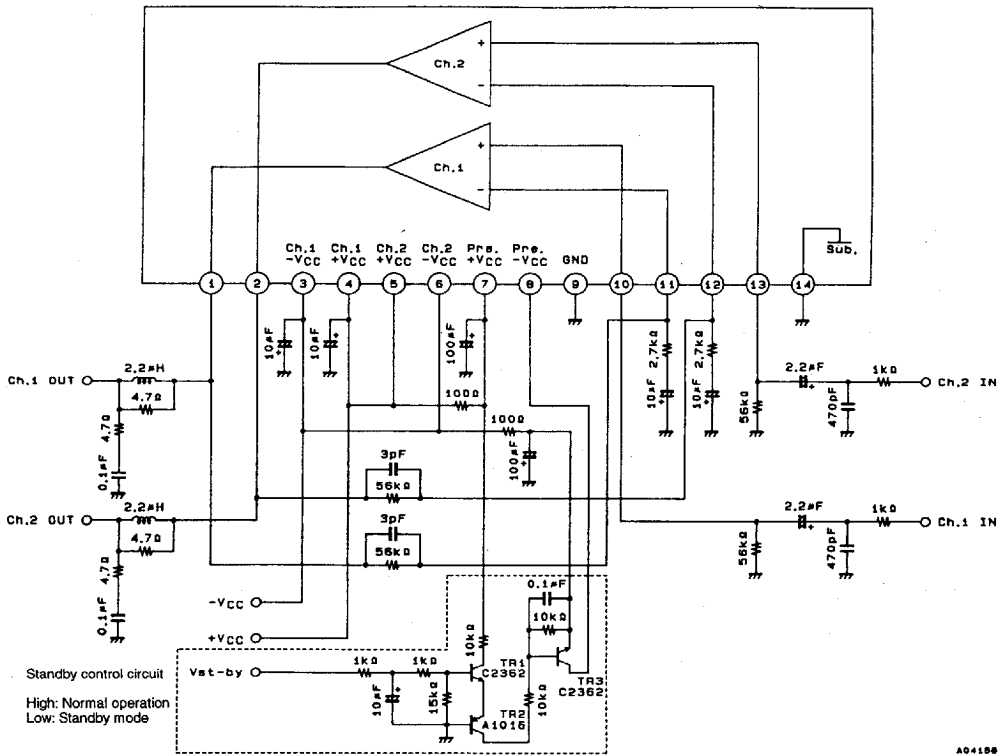

AA4188

Heatsink Design Considerations

The heatsink thermal resistance, θ_{c-a} , required to dissipate the STK405-090 device total power dissipation, P_d , is determined as follows:

Condition 1: IC substrate temperature not to exceed 125°C.

$$P_d \times \theta_{c-a} + T_a < 125^\circ\text{C} \dots\dots\dots (1)$$

where T_a is the guaranteed maximum ambient temperature.

Condition 2: Power transistor junction temperature, T_j , not to exceed 150°C.

$$P_d \times \theta_{c-a} + P_d/N \times \theta_{j-c} + T_a < 150^\circ\text{C} \dots\dots\dots (2)$$

where N is the number of power transistors and θ_{j-c} is the power transistor thermal resistance per transistor. Note that the power dissipated per transistor is the total, P_d , divided evenly among the N power transistors.

Expressions (1) and (2) can be rewritten making θ_{c-a} the subject.

$$\theta_{c-a} < (125 - T_a)/P_d \dots\dots\dots (1')$$

$$\theta_{c-a} < (150 - T_a)/P_d - \theta_{j-c}/N \dots\dots\dots (2')$$

The heatsink required must have a thermal resistance that simultaneously satisfies both expressions.

The heatsink thermal resistance can be determined from (1)' and (2)' once the following parameters have been defined.

- Supply voltage: V_{CC}
- Load resistance: R_L
- Guaranteed maximum ambient temperature: T_a

The total device power dissipation when STK405-090 $V_{CC} = \pm 26.5\text{V}$ and $R_L = 6\Omega$, for a continuous sine wave signal, is a maximum of 48W, as shown in the P_d-P_O characteristic graph.

When estimating the power dissipation for an actual audio signal input, the rule of thumb is to select P_d corresponding to 1/10 $P_{O \text{ max}}$ (within safe limits) for a continuous sine wave input. For example,

$$P_d = 34.5\text{W (for } 1/10 P_{O \text{ max}} = 5\text{W)}$$

The STK405-090 has 4 power transistors, and the thermal resistance per transistor, θ_{j-c} , is 2.7°C/W. If the guaranteed maximum ambient temperature, T_a , is 50°C, then the required heatsink thermal resistance, θ_{c-a} , is:

From expression (1)': $\theta_{c-a} < (125 - 50)/34.5 < 2.17$

From expression (2)': $\theta_{c-a} < (150 - 50)/34.5 - 2.7/4 < 2.22$

Therefore, to satisfy both expressions, the required heat-sink must have a thermal resistance less than 2.17°C/W.

This heatsink design example is based on a constant-voltage supply, and should be verified within your specific set environment.

