

**CABLE DRIVER FOR DIGITAL TRANSFER**

- 1 DIFFERENTIAL INPUT, 3 DIFFERENTIAL OUTPUTS
- SUFFICIENT DRIVE CAPABILITY FOR A 300m LENGTH COAXIAL CABLE
- STABILITY DUE TO MINIMAL WAVEFORM DISTORTION
- BIPOLAR SILICON MONOLITHIC IC

**APPLICATIONS**

- DATA TRANSFER BETWEEN DIGITAL SIGNAL PROCESSING EQUIPMENT

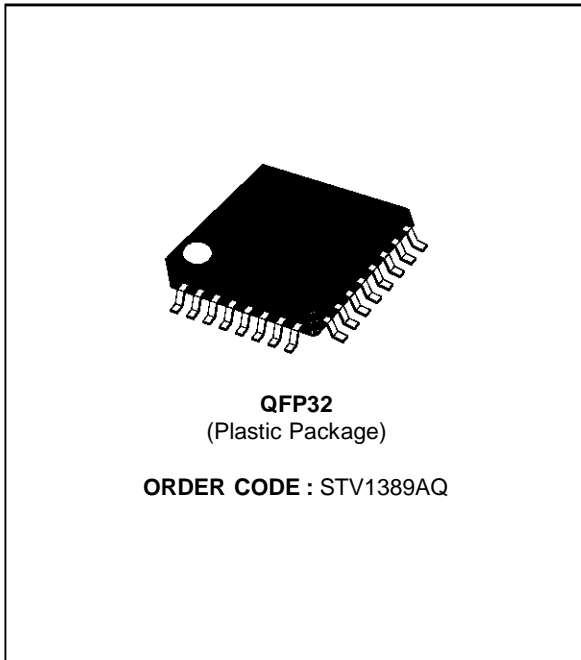

**DESCRIPTION**

The STV1389AQ offers in a single-chip a complete IC driver for digital data transfer.

**PIN CONNECTIONS**

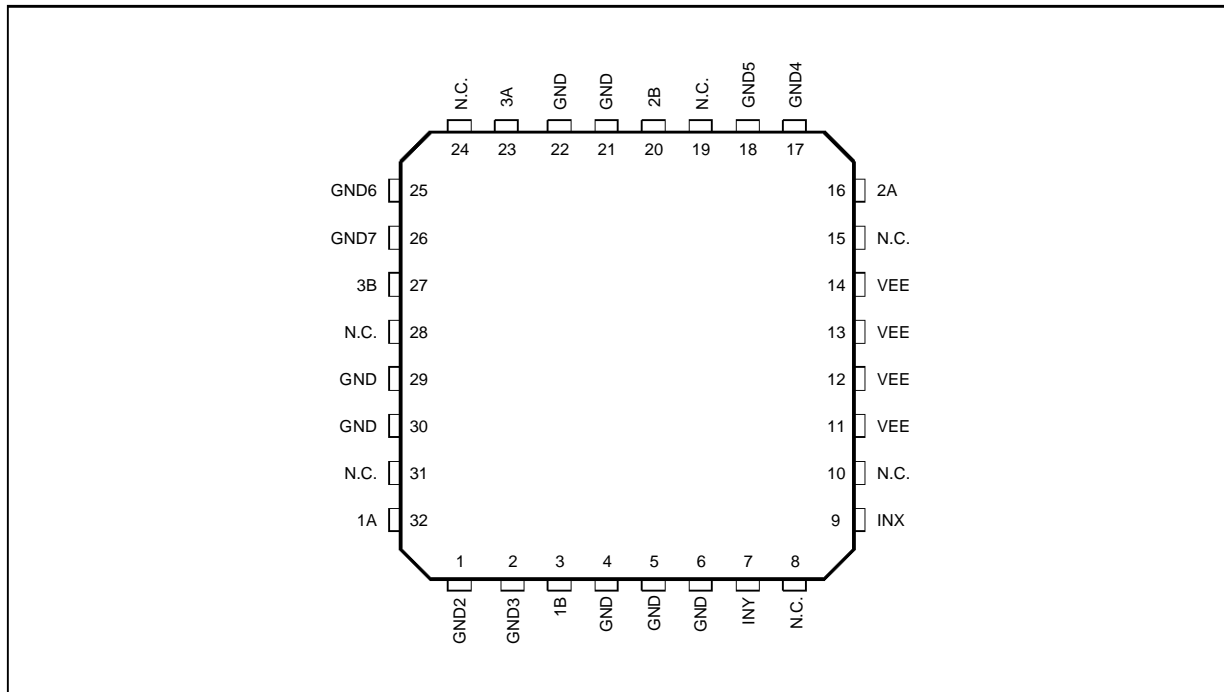

1389-01.EPS

PIN DESCRIPTION

| Pin Number                      | Symbol                                       | Standard DC Voltage | Equivalent Circuit | Description  |
|---------------------------------|--|---------------------|--------------------|--|
| 7<br>9                          | INY<br>INX                                   | - 2.7V              |                    | Input pin of the differential amplifier. Input executed after DC portion is cut off.   |
| 1<br>2<br>17<br>18<br>25<br>26  | GND2<br>GND3<br>GND4<br>GND5<br>GND6<br>GND7 | -                   |                    | Collector of the emitter follower output Tr.<br>Connect to GND.  |
| 32<br>3<br>16<br>20<br>23<br>27 | 1A<br>1B<br>2A<br>2B<br>3A<br>3B             | - 2.7V              |                    | Emitter of emitter follower output Tr.<br>To use, connect pull-down resistor. (Even when only 1 side is used pull-down is executed in pairs.)<br>Pairs 32 16 23<br>3 20 27 |

**BLOCK DIAGRAM**

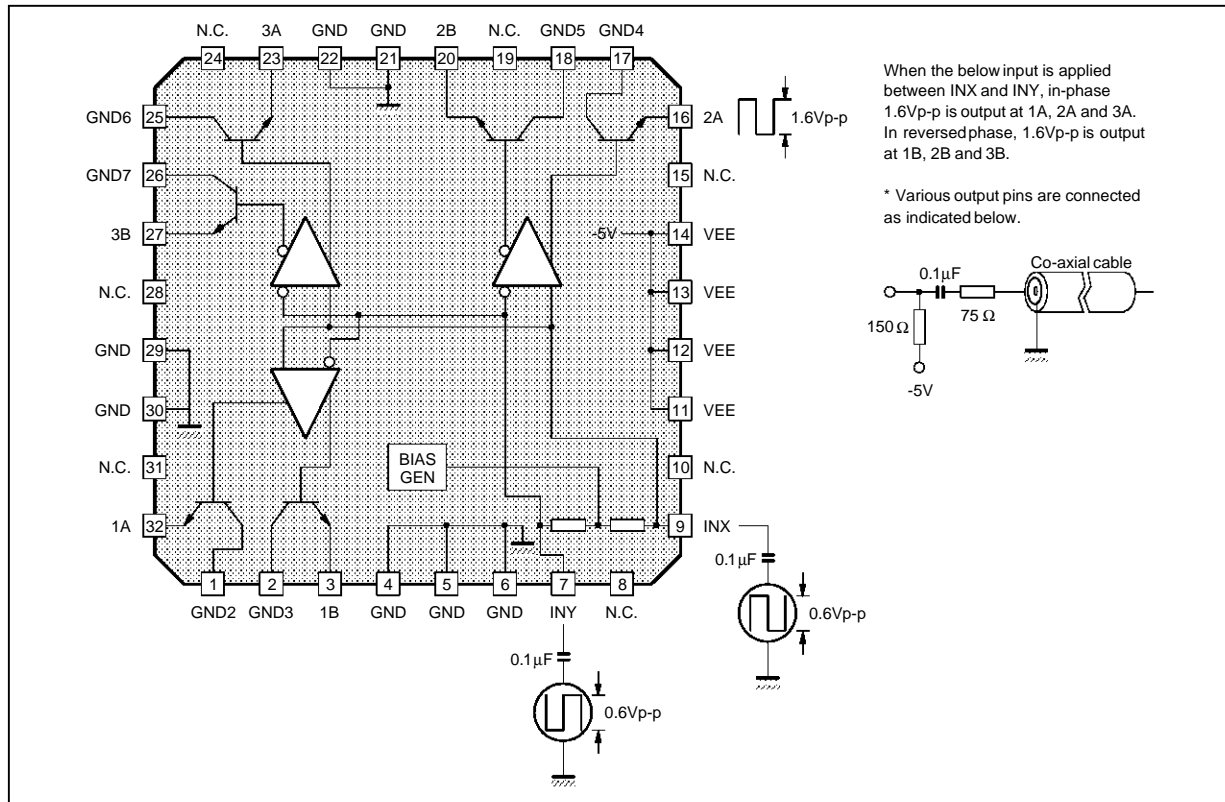

1389-04.EPS

**ABSOLUTE MAXIMUM RATINGS**

| Symbol    | Parameter                   | Value       | Unit |
|-----------|-----------------------------|-------------|------|
| $V_{CC}$  | Supply Voltage              | 7.0         | V    |
| $T_{stg}$ | Storage Temperature         | - 65, + 150 | °C   |
| $P_D$     | Allowable Power Dissipation | 500         | mW   |

1389-02.TBL

**OPERATING CONDITIONS**

| Symbol    | Parameter             | Value      | Unit |
|-----------|-----------------------|------------|------|
| $V_{CC}$  | Supply Voltage        | 4.8 to 5.2 | V    |
| $T_{opr}$ | Operating Temperature | - 20, + 75 | °C   |

1389-03.TBL

**ELECTRICAL CHARACTERISTICS**

| Symbol | Parameter       | Bias Conditions |       | SW ON | Test Point | Test                | Min.  | Typ.  | Max.  | Unit |
|--------|-----------------|-----------------|-------|-------|------------|---------------------|-------|-------|-------|------|
|        |                 | V INY           | V INX |       |            |                     |       |       |       |      |
| V1     | Pin Voltage INY | -               | -     | -     | Pin 7      | Test of pin voltage | - 2.9 | - 2.7 | - 2.5 | V    |
| V2     | Pin Voltage INX | -               | -     | -     | Pin 9      |                     | - 2.9 | - 2.7 | - 2.5 | V    |
| A1-1   | Pin Voltage 1A  | -               | -     | -     | Pin 32     |                     | - 3.1 | - 2.7 | - 2.5 | V    |
| B1-1   | Pin Voltage 1B  | -               | -     | -     | Pin 3      |                     | - 3.1 | - 2.7 | - 2.5 | V    |
| A2-1   | Pin Voltage 2A  | -               | -     | -     | Pin 16     |                     | - 3.1 | - 2.7 | - 2.5 | V    |
| B2-1   | Pin Voltage 2B  | -               | -     | -     | Pin 3      |                     | - 3.1 | - 2.7 | - 2.5 | V    |

1389-04.TBL

ELECTRICAL CHARACTERISTICS (T<sub>A</sub> = 25°C)

| Symbol | Parameter            | Bias Conditions |          | SW ON      | Test Point | Test  | Min.  | Typ.  | Max.  | Unit |   |
|--------|----------------------|-----------------|----------|------------|------------|---|-------|-------|-------|------|---|
|        |                      | V INY           | V INX    |            |            |   |       |       |       |      |   |
| A3-1   | Pin Voltage 3A       | -               | -        | -          | Pin 23     | Test of pin voltage   | - 3.1 | - 2.7 | - 2.5 | V    |   |
| B3-1   | Pin Voltage 3B       | -               | -        | -          | Pin 27     |   | - 3.1 | - 2.7 | - 2.5 | V    |   |
| IEE    | Current Power Supply | -               | -        | -          | VEE        | Current power supply at VEE   | - 143 |       | - 77  | mA   |   |
| A1-2   | DC applied 1A        | V1 + 0.2        | V2 - 0.2 | SW1<br>SW2 | Pin 32     | Output DC voltage is tested when +0.2V is applied to INY and - 0.2V to INX.<br>(A1-2) = Test value - (A1-1)<br>(B1-2) = Test value - (B1-1)<br>The difference with the previous pin voltage is recorded. Same for A2-2, B2-2, A3-2, B3-2  | 0.31  | 0.39  | 0.47  | V    |   |
| B1-2   | DC applied 1B        | ↓               | ↓        |            | Pin 3      |   | 0.47  | -     | -     | 0.31 | V |
| A2-2   | DC applied 2A        | ↓               | ↓        |            | Pin 16     |   | 0.31  | 0.39  | 0.47  | V    |   |
| B2-2   | DC applied 2B        | ↓               | ↓        |            | Pin 20     |   | 0.47  | -     | -     | 0.31 | V |
| A3-2   | DC applied 3A        | ↓               | ↓        |            | Pin 23     |   | 0.31  | 0.39  | 0.47  | V    |   |
| B3-2   | DC applied 3B        | ↓               | ↓        |            | Pin 27     |   | 0.47  | -     | -     | 0.31 | V |
| V1-1   | Amplitude 1A + 1B    | Calculation     |          |            |            | (V1-1) = (A1-2) - (B1-2)<br>Amplitude calculated from T10 with T15 as base, same for V2-1, V3-1.  | 0.65  | 0.75  | 0.85  | V    |   |
| V2-1   | Amplitude 2A + 2B    | Calculation     |          |            |            |   | 0.65  | 0.75  | 0.85  | V    |   |
| V3-1   | Amplitude 3A + 3B    | Calculation     |          |            |            |   | 0.65  | 0.75  | 0.85  | V    |   |
| -      | Amplitude 1A/1B      | Calculation     |          |            |            | (A1-2) / (B1-2)   | 0.85  | 1.0   | 1.15  | -    |   |
| -      | Amplitude 2A/2B      | Calculation     |          |            |            |   | 0.85  | 1.0   | 1.15  | -    |   |
| -      | Amplitude 3A/3B      | Calculation     |          |            |            |   | 0.85  | 1.0   | 1.15  | -    |   |
| A1-3   | DC applied 1A'       | V1 - 0.4        | V1 + 0.4 | SW1<br>SW2 | Pin 32     | Output DC voltage is tested when - 0.4V is applied to INY and + 0.4V to INX.<br>(A1-3) = Test value - (A1-1)<br>(B1-3) = Test value - (B1-1)<br>The difference with the previous pin voltage is recorded. Same for A2-3, B2-3, A3-3, B3-3 | - 0.9 | -     | - 0.6 | V    |   |
| B1-3   | DC applied 1B'       | ↓               | ↓        |            | Pin 3      |   | 0.6   | 0.75  | 0.9   | V    |   |
| A2-3   | DC applied 2A'       | ↓               | ↓        |            | Pin 16     |   | - 0.9 | -     | - 0.6 | V    |   |
| B2-3   | DC applied 2B'       | ↓               | ↓        |            | Pin 20     |   | 0.6   | 0.75  | 0.9   | V    |   |
| A3-3   | DC applied 3A'       | ↓               | ↓        |            | Pin 23     |   | - 0.9 | -     | - 0.6 | V    |   |
| B3-3   | DC applied 3B'       | ↓               | ↓        |            | Pin 27     |   | 0.6   | 0.75  | 0.9   | V    |   |
| V1-2   | Amplitude 1A' + 1B'  | Calculation     |          |            |            | (V1-2) = (A1-3) + (B1-3)<br>Amplitude calculated from T22 with T27 as base, same for V2-2, V3-2.  | 1.3   | 1.5   | 1.7   | V    |   |
| V2-2   | Amplitude 2A' + 2B'  | Calculation     |          |            |            |   | 1.3   | 1.5   | 1.7   | V    |   |
| V3-2   | Amplitude 3A' + 3B'  | Calculation     |          |            |            |   | 1.3   | 1.5   | 1.7   | V    |   |
| -      | Amplitude 1A' + 1B'  | Calculation     |          |            |            | (A1-3) / (B1-3)   | 0.85  | 1.0   | 1.15  | V    |   |
| -      | Amplitude 2A' + 2B'  | Calculation     |          |            |            | (A2-3) / (B2-3)   | 0.85  | 1.0   | 1.15  | V    |   |
| -      | Amplitude 3A' + 3B'  | Calculation     |          |            |            | (A3-3) / (B3-3)   | 0.85  | 1.0   | 1.15  | V    |   |
| V1-3   | Linearity 1          | Calculation     |          |            |            | (V1-2) / (V1-1)   | 1.7   | 1.9   | 2.1   | V    |   |
| V2-3   | Linearity 2          | Calculation     |          |            |            | (V2-2) / (V1-1)   | 1.7   | 1.9   | 2.1   | V    |   |
| V3-3   | Linearity 3          | Calculation     |          |            |            | (V3-2) / (V1-1)   | 1.7   | 1.9   | 2.1   | V    |   |

1389-05.TBL

TEST CIRCUIT

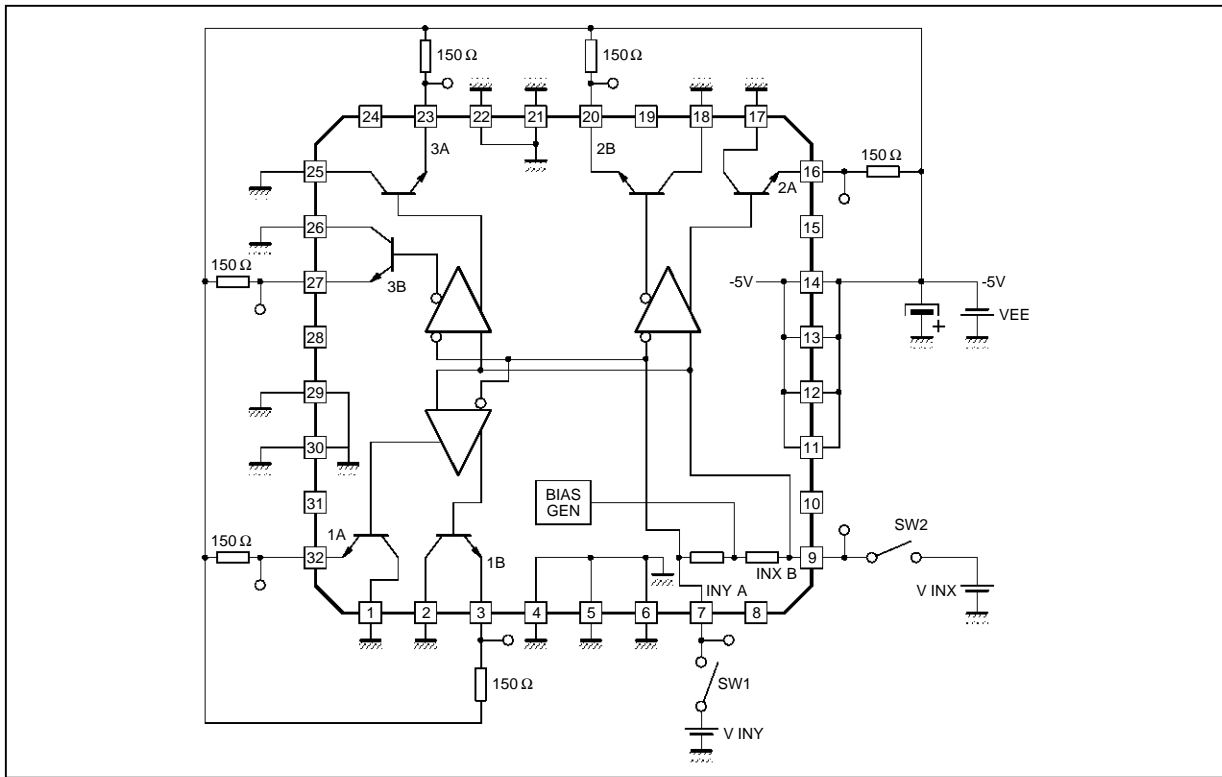

1389-06.EPS

DESCRIPTION OF OPERATION

The STV1389AQ consists of 3 differential amplifier with a common input and a bias generator, and three differential outputs. Each amplifiers provides a 6dB gain and is configured as a differential output feeding the bases of a pair of current boosting on-chip emitter follower transistors. The differential input pins are internally biased and the input signal is ac-coupled to remove the D.C. component. Between the output pins of each differential amplifier and the coaxial cable, an R-C network is con-

nected to remove D.C. component from the output and for impedance matching. The series resistor has a value of 68 to 75Ω to match a 75Ω coaxial cable. In this manner a signal almost identical in level to the input signal is transferred to the coaxial cable.

Optimum PCB layout and matching resistor value are chosen to obtain good eye pattern design at the input pins. This is necessary because the waveform distortion at the input pins is directly transferred to the output waveform.

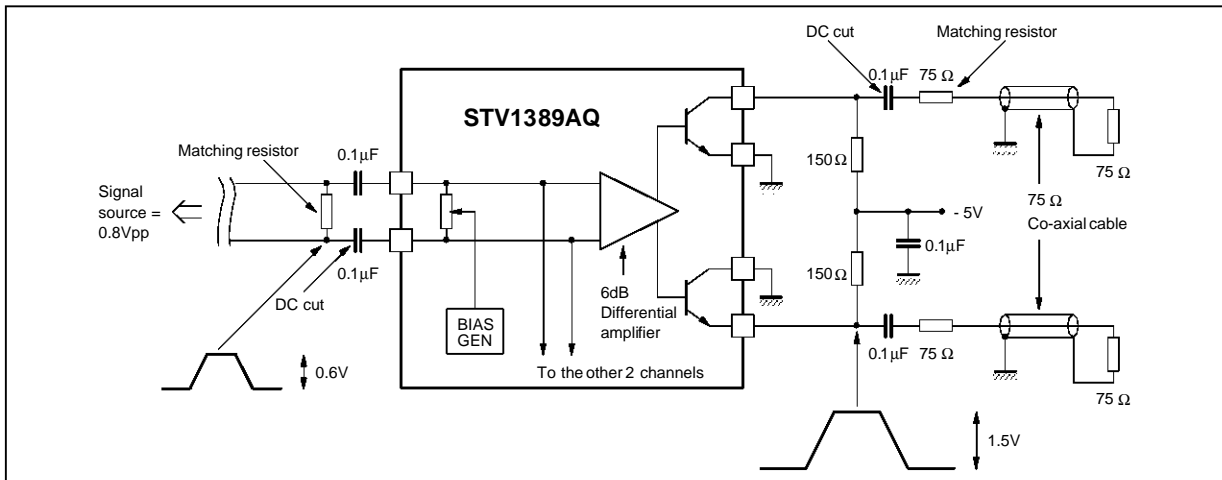

1389-06.EPS

TEST CIRCUIT

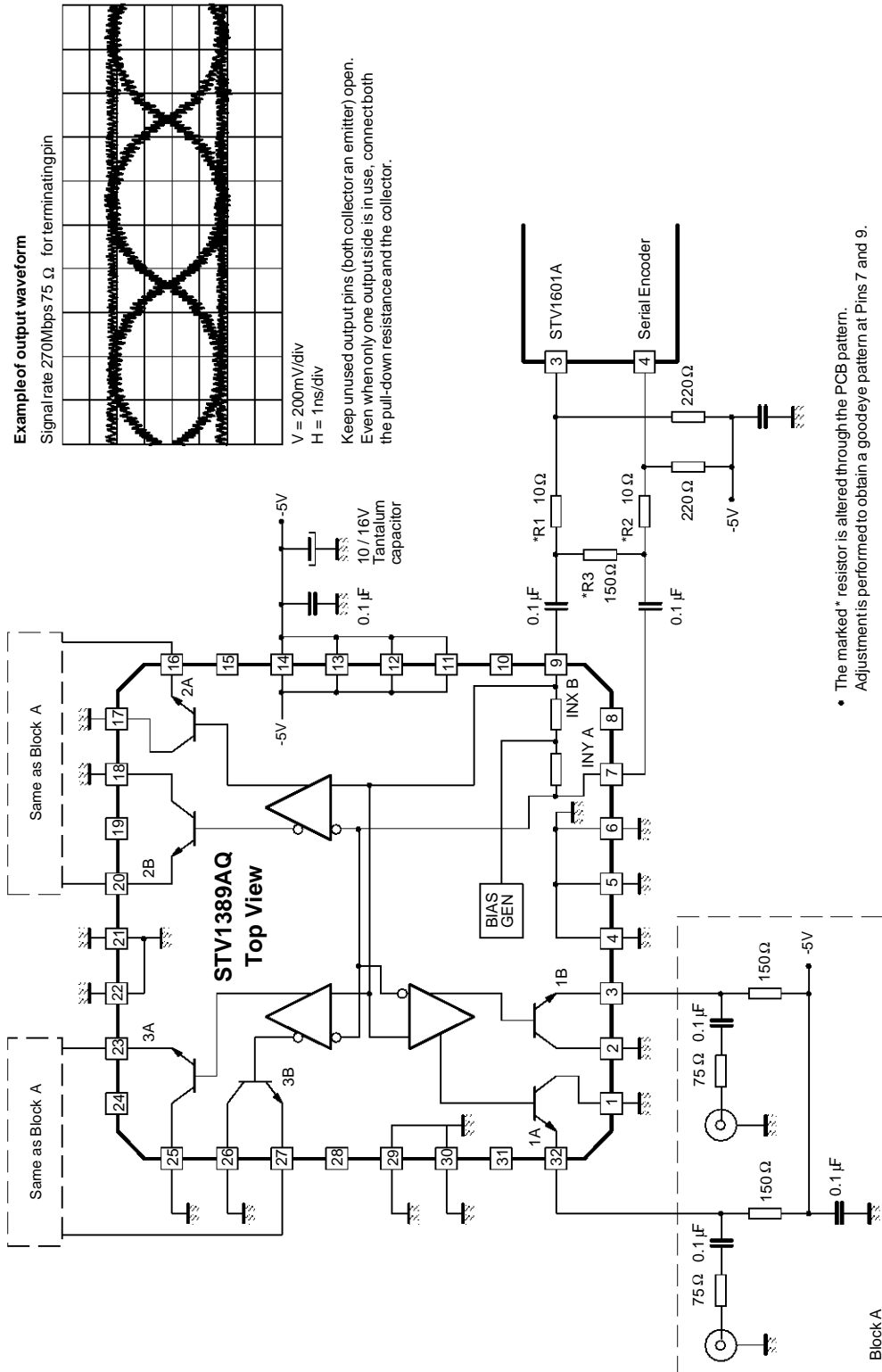

Example of output waveform

Signal rate 270Mbps 75 Ω for terminating pin

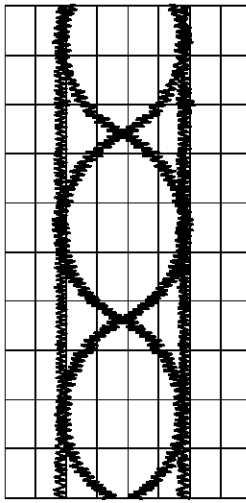

V = 200mV/div  
H = 1ns/div

Keep unused output pins (both collector and emitter) open. Even when only one output side is in use, connect both the pull-down resistance and the collector.

- The marked\* resistor is altered through the PCB pattern. Adjustment is performed to obtain a good eye pattern at Pins 7 and 9.
- Keep the GND pin pattern as short as possible and provide sufficient GND. A weak GND will cause unstable operation
- Since power consumption is large, conceive a pattern taking due consideration of the radiation from the PCB.

