

3-HEAD PLAYBACK AND RECORD AMPLIFIER FOR VCR

PRELIMINARY DATA

- ONE 5V POWER SUPPLY
- PLAYBACK/RECORD MODE SELECTION THROUGH A LOGIC INPUT
- SO20 PACKAGE
- NO ADJUSTMENT FOR LUMINANCE RECORDING

PLAYBACK MODE

- LOW NOISE AND WIDE BAND AMPLIFIERS FOR 3 HEADS
- AUTOMATIC OFFSET CANCELLATION BETWEEN THE 2 SELECTED HEADS
- ONE PLAYBACK OUTPUT
- ONE OUTPUT FOR AUTOMATIC VIDEO TRACKING

RECORD MODE

- RECORD AGC AMPLIFIER SAMPLED BY SYNCHRO SIGNAL
- RECORDING SIGNAL LEVEL ADJUSTABLE BY EXTERNAL RESISTOR

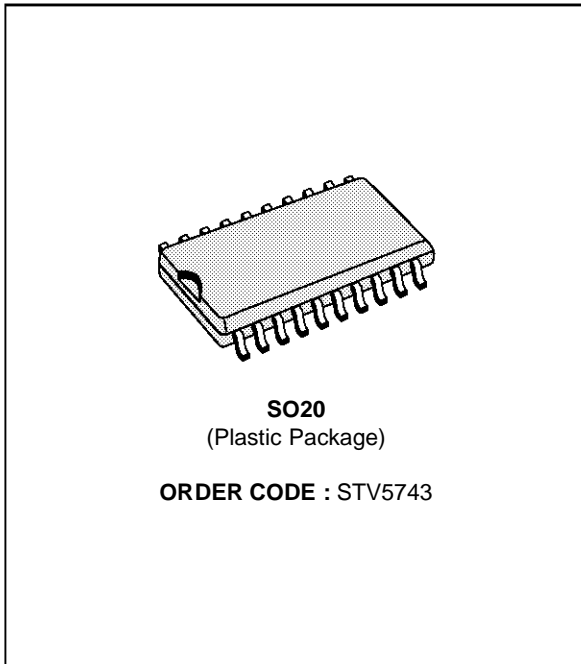

PIN CONNECTIONS

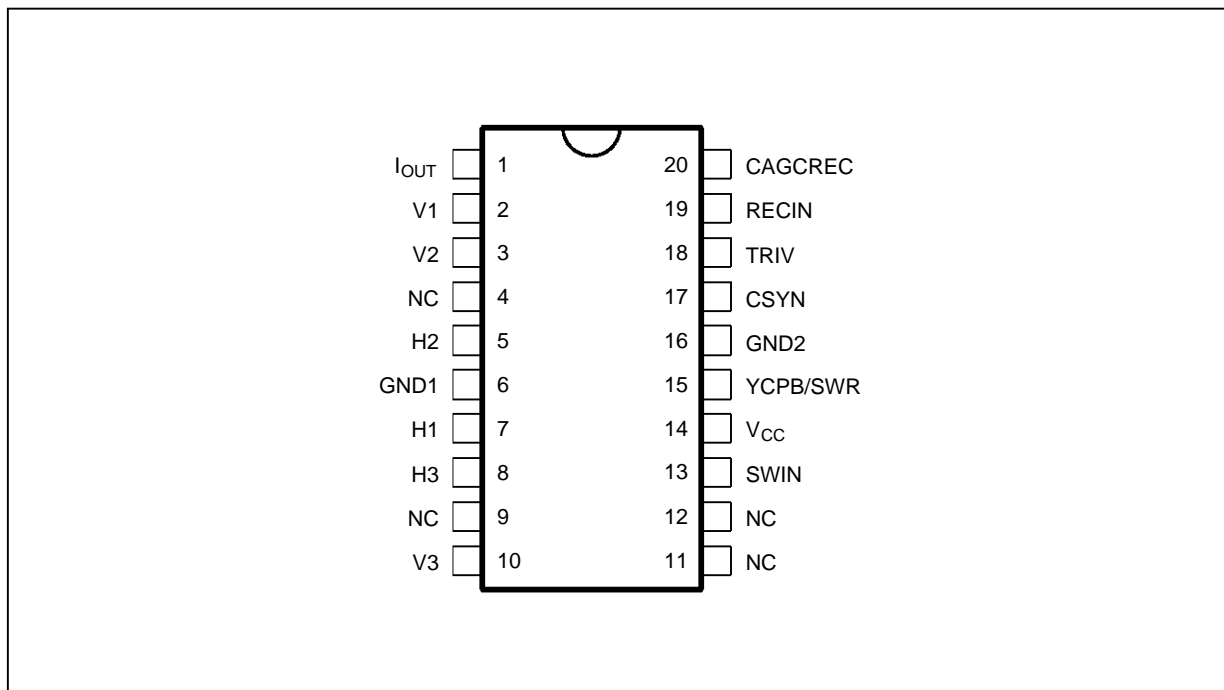

5743-01.EPS

BLOCK DIAGRAM

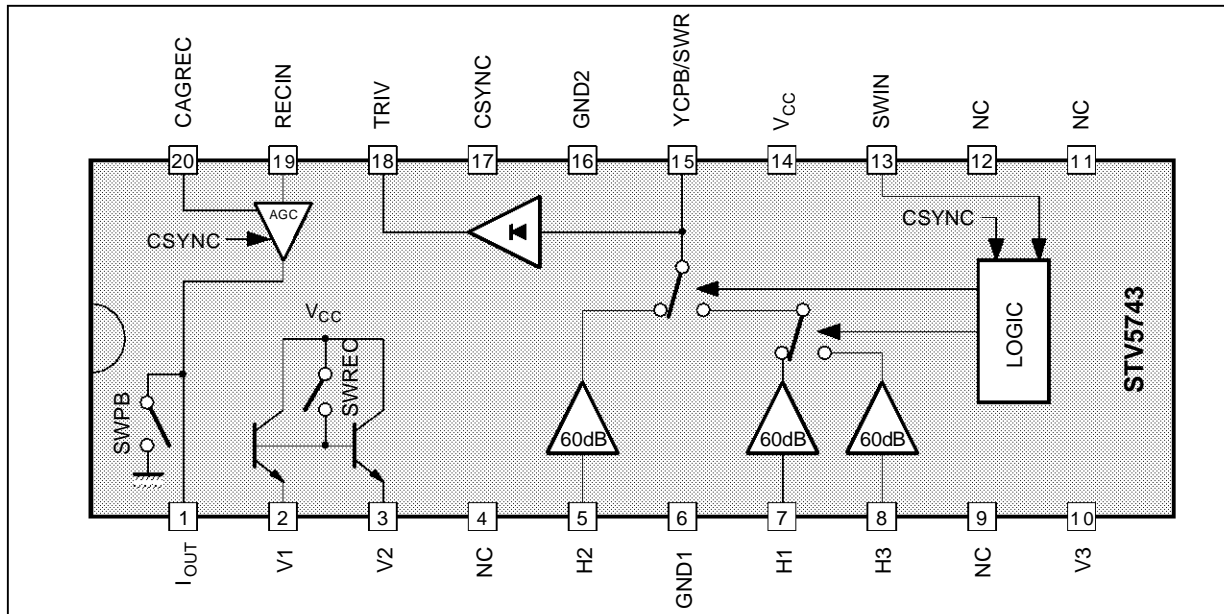

5743-02.EPS

ABSOLUTE MAXIMUM RATINGS

Symbol	Parameter	Value	Unit
V _{CC}	Power Supply Voltage	6	V
T _j	Junction Temperature	150	°C
T _{oper}	Operating Temperature	0, +70	°C

5743-01.TBL

THERMAL DATA

Symbol	Parameter	Value	Unit
R _{th(j-a)}	Junction-ambient Thermal Resistance	Max. 75	°C/W

5743-02.TBL

RECOMMENDED OPERATING CHARACTERISTICS

Symbol	Parameter	Min.	Typ.	Max.	Unit
V _{CC}	Power Supply	4.75	5	5.25	V
CAGC	Capacitance on Pin CAGCREC	4.7			nF
RECADJ	Record Biasing Resistor	10		33	kΩ

5743-03.TBL

ELECTRICAL CHARACTERISTICS ($T_{amb} = 25^{\circ}\text{C}$, unless otherwise specified)**Playback Mode** ($V_{CC} = 5\text{V}$, no load on Pin YCPB, Recadj = $12\text{k}\Omega$)

Symbol	Parameter	Test Conditions	Min.	Typ.	Max.	Unit
--------	-----------	-----------------	------	------	------	------

PLAYBACK AMPLIFIER

I _{CC1}	Supply Current		42	52	62	mA
GPB	Playback Gain	Sinewave 600kHz, 0.4mV _{PP} on inputs	58	60	62	dB
EN	Equivalent Voltage Noise	Input grounded via I _{OUT} Pin @ 600kHz, BW = 10kHz		0.6	0.7	$\frac{\text{nV}}{\sqrt{\text{Hz}}}$
IN	Equivalent Input Current Noise	Input open @ 6MHz, BW = 10kHz		1.7		$\frac{\text{pA}}{\sqrt{\text{Hz}}}$
CRT1	Crosstalk (H3-H1)	Sinewave @ 4MHz, 0.4mV _{PP}		-45	-40	dB
CRT2	Crosstalk (H2-H1)	Sinewave @ 4MHz, 0.4mV _{PP}		-41	-35	dB
RPBSW	Playback Switch on Resistor	@ 6MHz	5	10	15	Ω
BWLCF	Attenuation @ 100KHz	Reference level @ 600kHz	-3	-2	1	dB
BWHCF	Attenuation @ 8MHz	Reference level @ 4MHz	-3	-1	0	dB
C _{IN}	Input Capacitance	@ 6MHz, 22nF between Vi/Hi	40	50	60	pF
Z _{IN}	Input Impedance	@ 6MHz	300	450	600	Ω
ZCPB	Output Resistance	DC	5	24	50	Ω
VDCPB1	DC Level on Pin YCPB		1.6	2	2.4	V
DVDC	Head Switch Offset		-0.2	0	0.2	V
SHPB1	2nd Harmonic	Sinewave @ 4MHz, 0.4mV _{PP}		-45	-40	dB

TRIV FUNCTION

TRIV0	Output Level (1)	No input signal	0	0.3	1	V
TRIV1	Output Level (2)	Sinewave @ 4MHz, 100mV _{PP} @ YCPB		1.3		V
TRIV4	Output Level (3)	Sinewave @ 4MHz, 400mV _{PP} @ YCPB	2.5	3.1	3.5	V
TRIV6	Output Level (4)	Sinewave @ 4MHz, 600mV _{PP} @ YCPB	3.15	3.65	4.15	V
TRIV1 - TRIV0			0.5	1		V

5743-04.TBL

ELECTRICAL CHARACTERISTICS ($T_{amb} = 25^{\circ}C$, unless otherwise specified (continued))

Record Mode ($V_{CC} = 5V$, $Recadj = 12k\Omega$, $SWR = 5V$, $CAGCREC = 470pF$, $RRCY = 2.2k\Omega$, $RRCC = 8.2k\Omega$, Load $10\mu H//1k\Omega$ for each simulated head)

Symbol	Parameter	Test Conditions	Min.	Typ.	Max.	Unit
--------	-----------	-----------------	------	------	------	------

RECORD AMPLIFIER

I _{CC2}	Current Supply		68	91	115	mA
I _{HA0}	DC Current through I _{OUT}		24	33	41	mA
I _{HA1}	Fundamental	V _{RCY} = 300mV _{PP} @ 4MHz	30	32	34	mA _{PP}
I _{HA2}	2nd Harmonic	V _{RCY} = 300mV _{PP} @ 4MHz		-40	-36	dB
I _{HA2M}	2nd Harmonic	V _{RCY} = 400mV _{PP} @ 4MHz, AGC adjusted for I _{AH1} = 40mA _{PP}			-34	dB
BWRECL	Attenuation at 100kHz	Reference level @ 600kHz, AGC locked	-3	0	1	dB
BWRECH	Attenuation at 8MHz	Reference level @ 4MHz, AGC locked	-2	-0.5	1	dB
DVLREC	Record AGC Sensitivity	V _{IN} = 300mV _{PP} ±3dB @ f = 4MHz	-0.2	0	+0.2	dB
RIOUT	Output Resistance	ΔV = 5V	3.5	5.5		kΩ
RSAT	Output Stage Resistance	ΔI = 10mA	5	10	50	Ω
IRN	AGC Capacitor downloading Current	4.5V at CAGC Pin		160		μA
IRP	AGC Capacitor uploading Current	0.5V at CAGC Pin, V _{IN} = 300mV _{PP} @ 4MHz		-165		μA

SWITCHING LEVELS

V _{SWINL}	SWIN Input Voltage	Selects head H2	0		0.8	V
V _{SWIN1}	SWIN Input Voltage	Selects head H1	1.3		2.3	V
V _{SWIN2}	SWIN Input Voltage	Selects head H3	2.8		3.8	V
I _{SWINH}	SWIN Input Leakage Current	5V at SWIN input		0.5		μA
I _{SWINL}	SWIN Input Leakage Current	0V at SWIN input		-0.2		μA
V _{SWRCH}	SWRC Input Threshold	Selects record mode, 0 to 5V	3.2	3.4	3.8	V
V _{SWRCL}	SWRC Input Threshold	Selects playback mode, 5 to 0V	3.1	3.35	3.8	V
I _{SWRCH}	SWRC Input Leakage Current	5V at SWRC input	2	5	8	mA
I _{SWRCL}	SWRC Input Leakage Current	0V at SWRC input	-20	0	20	μA
t _{ON}	Delay	Signal appears on YCPB		1.6		ms
t ₁	Delay from playback to record : Signal disappears on Pin YCPB	22nF between Hi/Vi		1		μs
t ₂	Delay from record to playback : Signal appears on Pin YCPB			1.9		ms
t ₃	Delay from playback to record : Signal appears on Pin I _{OUT}	V _{RCY} = 300mV _{PP} @ 4MHz		2		ms
t ₄	Delay from record to playback : Signal disappears on Pin I _{OUT}			10		μs
V _{CSYH}	CSYN Input Threshold	Sampling on, 0 to 5V	2.0	2.7	3.2	V
V _{CSYL}	CSYN Input Threshold	Sampling off, 5 to 0V	2.0	2.6	3.1	V
I _{CSYH}	Leakage Current	5V at CSYN Pin, Sampling on	-10	0	10	μA
I _{CSYL}	Leakage Current	0V at CSYN Pin, Sampling off	-50	-16	-5	μA

5743-05.TBL

APPLICATION DIAGRAM

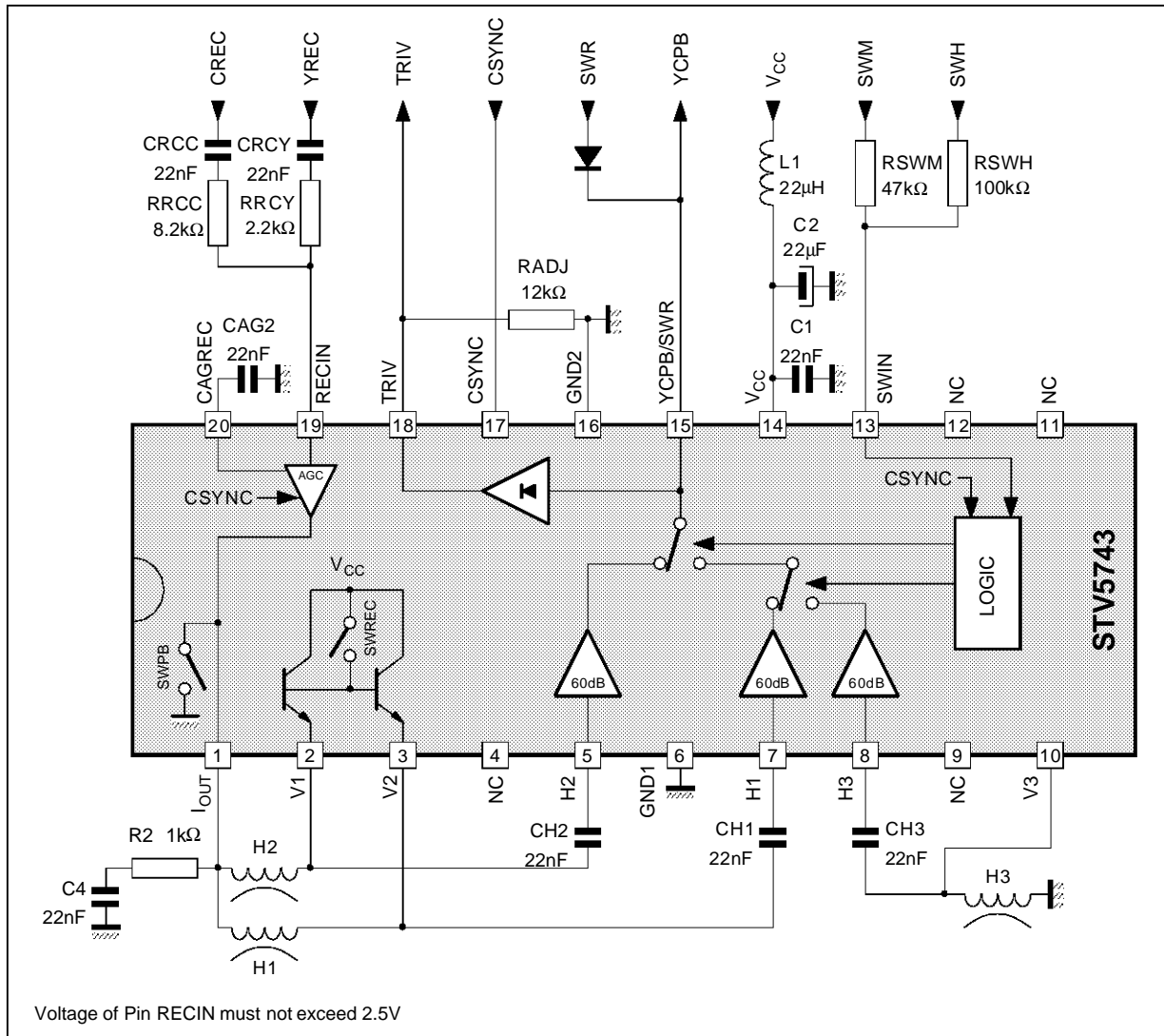

5743-03.EPS

SWITCH TABLE

SW-R	SW-M	SW-H	Channel	SWPB	SWREC
L	L	L	2	ON	OFF
		H	1		
	H	3			
H	L	L	1	OFF	ON
		H	2		
	H	Not allowed			

5743-06.TBL

PACKAGE MECHANICAL DATA
 20 PINS - PLASTIC MICROPACKAGE (SO)

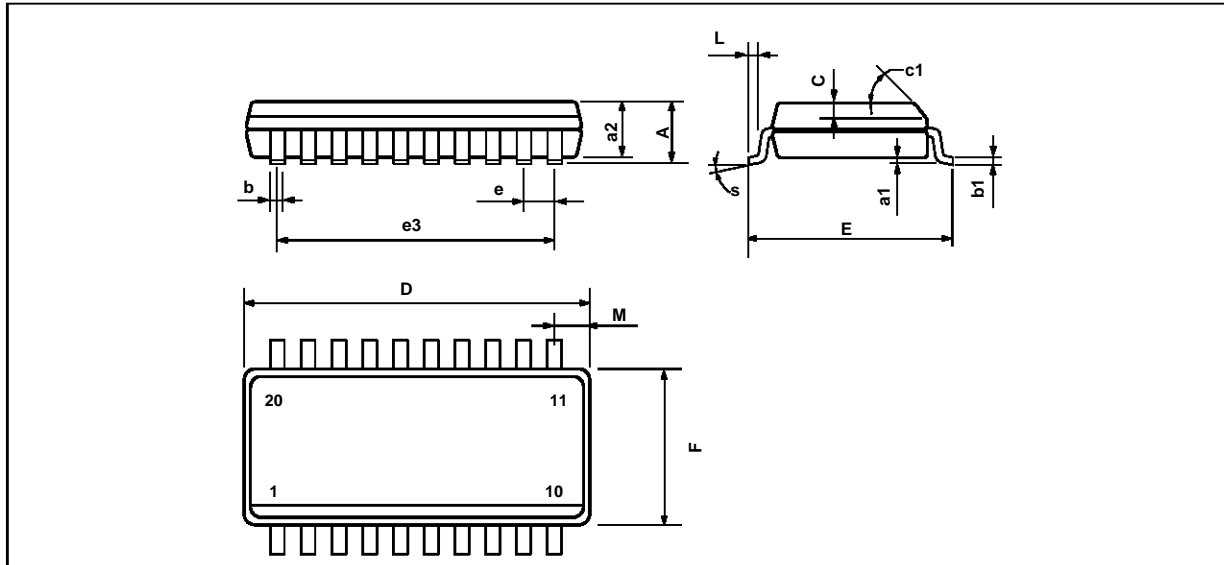

PM-SO20L.EPS

Dimensions	Millimeters			Inches		
	Min.	Typ.	Max.	Min.	Typ.	Max.
A			2.65			0.104
a1	0.1		0.2	0.004		0.008
a2			2.45			0.096
b	0.35		0.49	0.014		0.019
b1	0.23		0.32	0.009		0.013
C		0.5			0.020	
c1	45° (typ.)					
D	12.6		13.0	0.496		0.510
E	10		10.65	0.394		0.419
e		1.27			0.050	
e3		11.43			0.450	
F	7.4		7.6	0.291		0.300
L	0.5		1.27	0.020		0.050
M			0.75			0.030
S	8° (max.)					

SC20L.TBL

Information furnished is believed to be accurate and reliable. However, SGS-THOMSON Microelectronics assumes no responsibility for the consequences of use of such information nor for any infringement of patents or other rights of third parties which may result from its use. No licence is granted by implication or otherwise under any patent or patent rights of SGS-THOMSON Microelectronics. Specifications mentioned in this publication are subject to change without notice. This publication supersedes and replaces all information previously supplied. SGS-THOMSON Microelectronics products are not authorized for use as critical components in life support devices or systems without express written approval of SGS-THOMSON Microelectronics.

© 1995 SGS-THOMSON Microelectronics - All Rights Reserved

Purchase of I²C Components of SGS-THOMSON Microelectronics, conveys a license under the Philips I²C Patent. Rights to use these components in a I²C system, is granted provided that the system conforms to the I²C Standard Specifications as defined by Philips.

SGS-THOMSON Microelectronics GROUP OF COMPANIES

Australia - Brazil - China - France - Germany - Hong Kong - Italy - Japan - Korea - Malaysia - Malta - Morocco
 The Netherlands - Singapore - Spain - Sweden - Switzerland - Taiwan - Thailand - United Kingdom - U.S.A.