

4-HEAD PLAYBACK AND RECORD AMPLIFIER FOR VCR

PRELIMINARY DATA

- ONE 5V POWER SUPPLY
- PLAYBACK/RECORD MODE SELECTION THROUGH A LOGIC INPUT
- SO20 PACKAGE
- NO ADJUSTMENT FOR LUMINANCE RE-CORDING

PLAYBACK MODE

- LOW NOISE AND WIDE BAND AMPLIFIERS FOR 4 HEADS
- AUTOMATIC OFFSET CANCELLATION BETWEEN THE 2 SELECTED HEADS
- ONE PLAYBACK OUTPUT
- ONE OUTPUT FOR AUTOMATIC VIDEO TRACKING
- SP/LP ENVELOPE COMPARATOR
- SHORT-CIRCUIT SWITCHES ON UNUSED HEADS

RECORD MODE

- RECORD AGC AMPLIFIER SAMPLED BY SYNCHRO SIGNAL
- RECORDING SIGNAL LEVEL ADJUSTABLE BY EXTERNAL RESISTOR
- SHORT-CIRCUIT SWITCHES ON UNUSED HEADS

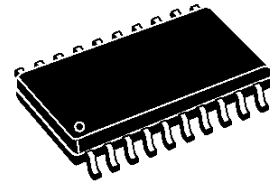

SO20
(Plastic Micropackage)

ORDER CODE : STV5744

PIN CONNECTIONS

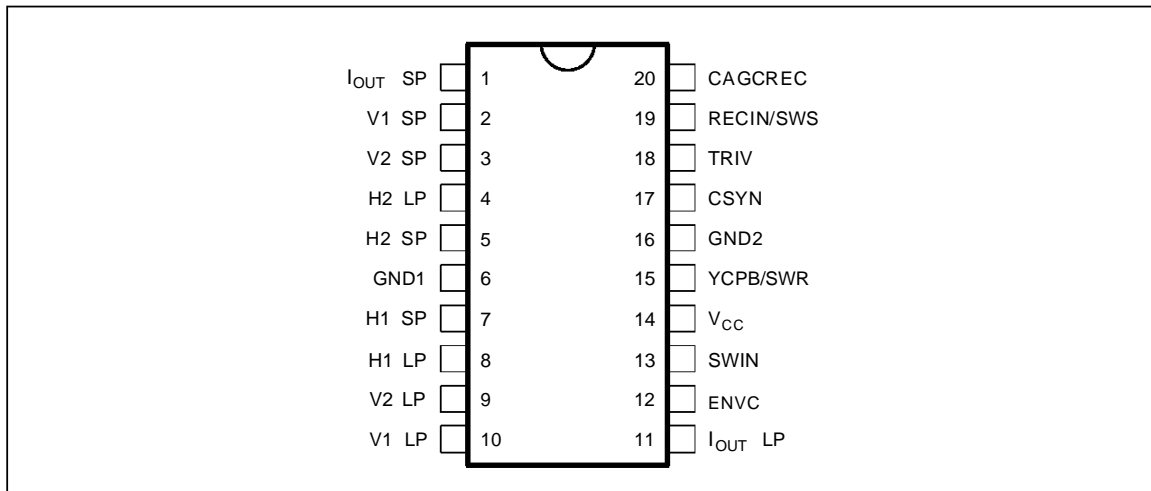

5744-01.EPS

ELECTRICAL CHARACTERISTICS ($T_{amb} = 25^{\circ}\text{C}$, unless otherwise specified)**Playback Mode** ($V_{CC} = 5\text{V}$, no load on Pin YCPB, Recadj = $12\text{k}\Omega$)

Symbol	Parameter	Test Conditions	Min.	Typ.	Max.	Unit
--------	-----------	-----------------	------	------	------	------

PLAYBACK AMPLIFIER

I _{CC1}	Supply Current		42	52	62	mA
GPB	Playback Gain	Sinewave 600kHz, 0.4mV _{PP} on inputs	58	60	62	dB
EN	Equivalent Voltage Noise	Input grounded via I _{OUT} Pin @ 600kHz, BW = 10kHz		0.6	0.7	$\frac{\text{nV}}{\sqrt{\text{Hz}}}$
IN	Equivalent Input Current Noise	Input open @ 6MHz, BW = 10kHz		1.7		$\frac{\text{pA}}{\sqrt{\text{Hz}}}$
CRT1	Crosstalk (LP → SP)	Sinewave @ 4MHz, 0.4mV _{PP}		-45	-40	dB
CRT2	Crosstalk (SP → LP)	Sinewave @ 4MHz, 0.4mV _{PP}		-41	-35	dB
RPBSW	Playback Switch on Resistor	@ 6MHz	5	10	15	Ω
BWLCF	Attenuation @ 100KHz	Reference level @ 600kHz	-3	-2	1	dB
BWHCF	Attenuation @ 8MHz	Reference level @ 4MHz	-3	-1	0	dB
C _{IN}	Input Capacitance	@ 6MHz, 22nF between Vi/Hi	40	50	60	pF
Z _{IN}	Input Impedance	@ 6MHz	300	450	600	Ω
ZCPB	Output Resistance	DC	5	24	50	Ω
VDCPB1	DC Level on Pin YCPB		1.6	2	2.4	V
DVDC	Head Switch Offset		-0.2	0	0.2	V
SHPB1	2nd Harmonic	Sinewave @ 4MHz, 0.4mV _{PP}		-45	-40	dB
RCST	Off-resistance on unused channel	SW-S high	10	15	20	Ω

TRIV FUNCTION

TRIV0	Output Level (1)	No input signal	0	0.3	1	V
TRIV1	Output Level (2)	Sinewave @ 4MHz, 100mV _{PP} @ YCPB		1.3		V
TRIV4	Output Level (3)	Sinewave @ 4MHz, 400mV _{PP} @ YCPB	2.5	3.1	3.5	V
TRIV6	Output Level (4)	Sinewave @ 4MHz, 600mV _{PP} @ YCPB	3.15	3.65	4.15	V
TRIV1 - TRIV0			0.5	1		V

SP/LP ENVELOPE DETECTOR

VENVCH	Output Level		4	4.5	5	V
VENVCL	Output Level		0	0.3	1	V
SENS1	Sensitivity	50 μV_{PP} to 600 μV_{PP} @ SP input pins		0.3	1	V
SENS2	Sensitivity	50 μV_{PP} to 600 μV_{PP} @ LP input pins	4	4.5		V

5744-04.TBL

ELECTRICAL CHARACTERISTICS ($T_{amb} = 25^{\circ}\text{C}$, unless otherwise specified (continued))

Record Mode ($V_{CC} = 5\text{V}$, $\text{Recadj} = 12\text{k}\Omega$, $\text{SWR} = 5\text{V}$, $\text{CAGCREC} = 470\text{pF}$, $\text{RRCY} = 2.2\text{k}\Omega$, $\text{RRCC} = 8.2\text{k}\Omega$, Load $10\mu\text{H}/1\text{k}\Omega$ for each simulated head)

Symbol	Parameter	Test Conditions	Min.	Typ.	Max.	Unit
RECORD AMPLIFIER						
I_{CC2}	Current Supply		68	91	115	mA
IHA0	DC Current through I_{OUT}		24	33	41	mA
IHA1	Fundamental	$V_{RCY} = 300\text{mV}_{PP} @ 4\text{MHz}$	30	32	34	mA_{PP}
IHA2	2nd Harmonic	$V_{RCY} = 300\text{mV}_{PP} @ 4\text{MHz}$		-40	-36	dB
IHA2M	2nd Harmonic	$V_{RCY} = 400\text{mV}_{PP} @ 4\text{MHz}$, AGC adjusted for IAH1 = 40mA_{PP}			-34	dB
BWRECL	Attenuation at 100kHz	Reference level @ 600kHz, AGC locked	-3	0	1	dB
BWRECH	Attenuation at 8MHz	Reference level @ 4MHz, AGC locked	-2	-0.5	1	dB
DVLREC	Record AGC Sensitivity	$V_{IN} = 300\text{mV}_{PP} \pm 3\text{dB} @ f = 4\text{MHz}$	-0.2	0	+0.2	dB
RIOUT	Output Resistance	$\Delta V = 5\text{V}$	3.5	5.5		$\text{k}\Omega$
RSAT	Output Stage Resistance	$\Delta I = 10\text{mA}$	5	10	50	Ω
IRN	AGC Capacitor downloading Current	4.5V at CAGC Pin		160		μA
IRP	AGC Capacitor uploading Current	0.5V at CAGC Pin, $V_{IN} = 300\text{mV}_{PP} @ 4\text{MHz}$		-165		μA

SWITCHING LEVELS

VSWINL	SWIN Input Voltage	Selects head H2SP	0		0.8	V
VSWIN1	SWIN Input Voltage	Selects head H1SP	1.3		2.3	V
VSWIN2	SWIN Input Voltage	Selects head H1LP	2.8		3.8	V
VSWINH	SWIN Input Voltage	Selects head H2LP	4.3		5	V
ISWINH	SWIN Input Leakage Current	5V at SWIN input		0.5		μA
ISWINL	SWIN Input Leakage Current	0V at SWIN input		-0.2		μA
VSWRCH	SWRC Input Threshold	Selects record mode, 0 to 5V	3.2	3.4	3.8	V
VSWRCL	SWRC Input Threshold	Selects playback mode, 5 to 0V	3.1	3.35	3.8	V
ISWRCH	SWRC Input Leakage Current	5V at SWRC input	2	5	8	mA
ISWRCL	SWRC Input Leakage Current	0V at SWRC input	-20	0	20	μA
t_{ON}	Delay	Signal appears on YCPB		1.6		ms
t_1	Delay from playback to record : Signal disappears on Pin YCPB	22nF between Hi/Vi		1		μs
t_2	Delay from record to playback : Signal appears on Pin YCPB			1.9		ms
t_3	Delay from playback to record : Signal appears on Pin I_{OUT}	$V_{RCY} = 300\text{mV}_{PP} @ 4\text{MHz}$		2		ms
t_4	Delay from record to playback : Signal disappears on Pin I_{OUT}			10		μs
VCSYH	CSYN Input Threshold	Sampling on ($I = -25\mu\text{A}$)	2.2	2.5	2.8	V
VCSYL	CSYN Input Threshold	Sampling off ($I = 25\mu\text{A}$)	2.2	2.5	2.8	V
ICSYH	Leakage Current	Sampling on			-10	μA
ICSYL	Leakage Current	Sampling off	10			μA
VSWST	SWS Input Threshold			3		V
ISWSH	SWS Input Leakage Current	5V at SWS Input	90	130	170	μA
ISWSL	SWS Input Leakage Current	0V at SWS Input	-20	0	20	μA

INTERNAL SCHEMATICS

Figure 1

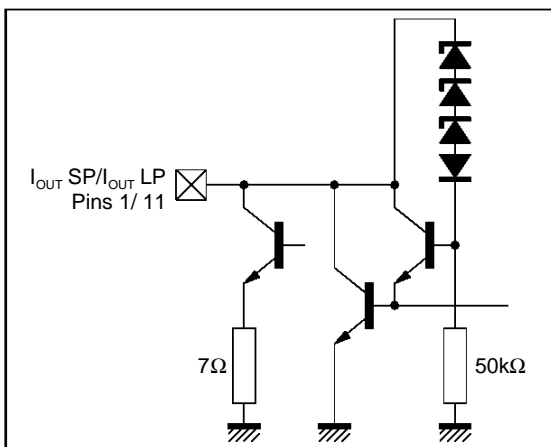

Figure 2

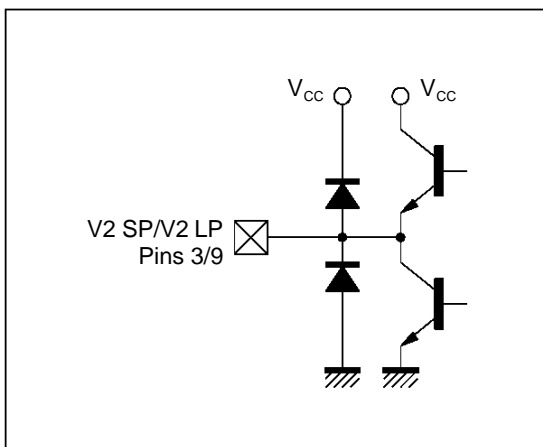

Figure 3

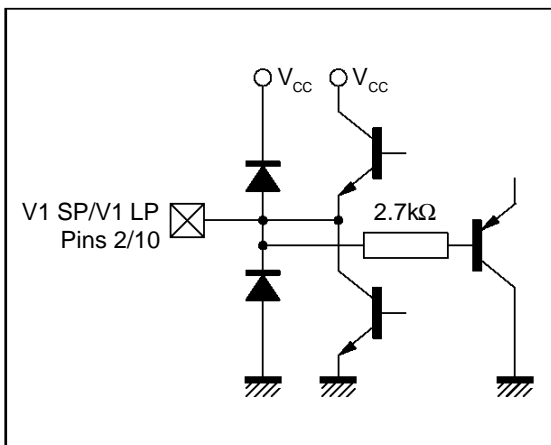

Figure 4

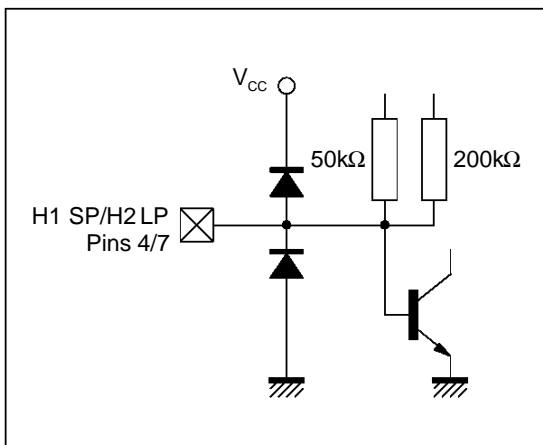

Figure 5

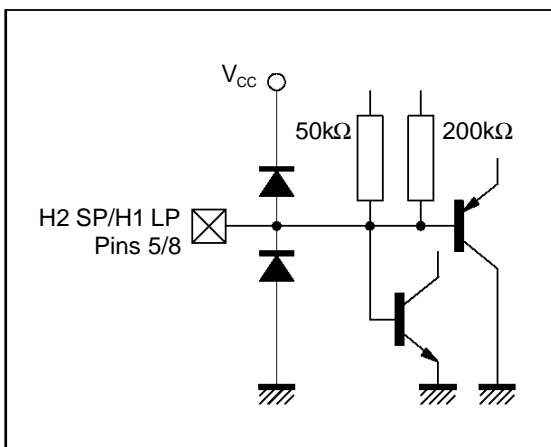
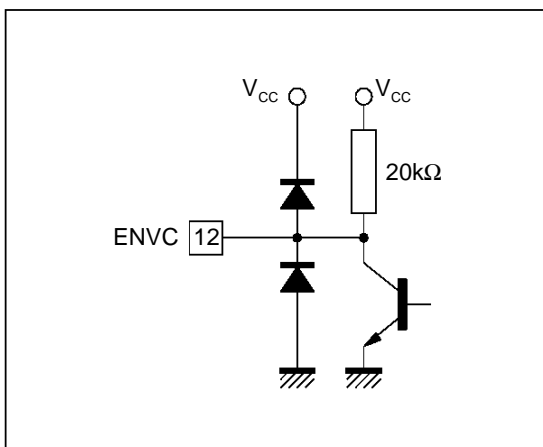
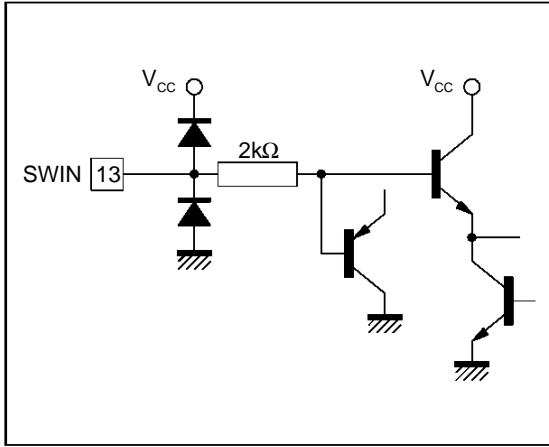

Figure 6



INTERNAL SCHEMATICS (continued)

Figure 7



5744-09.EPS

Figure 8

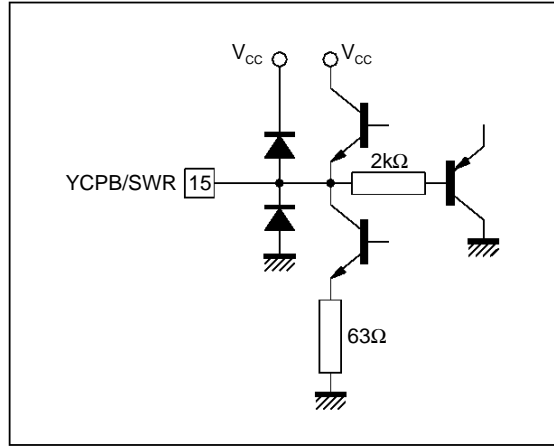

5744-10.EPS

Figure 9

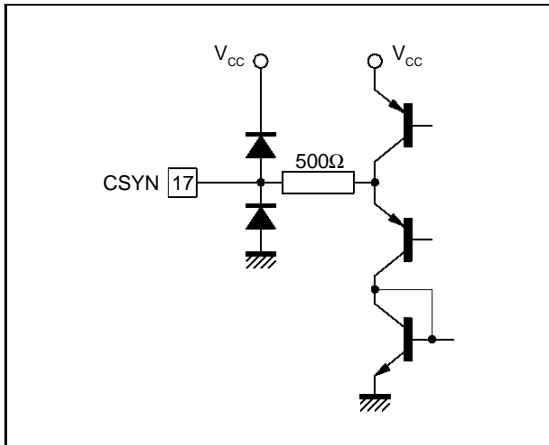

5744-11.EPS

Figure 10

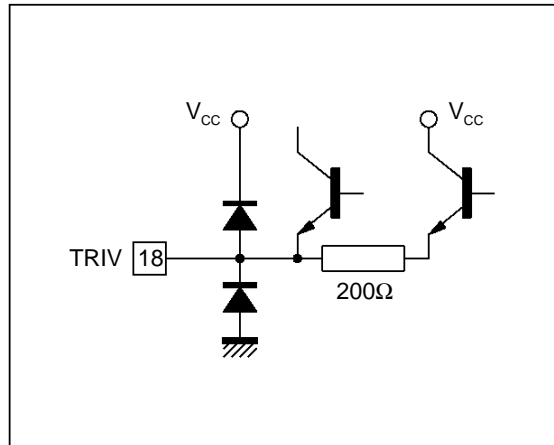

5744-12.EPS

Figure 11

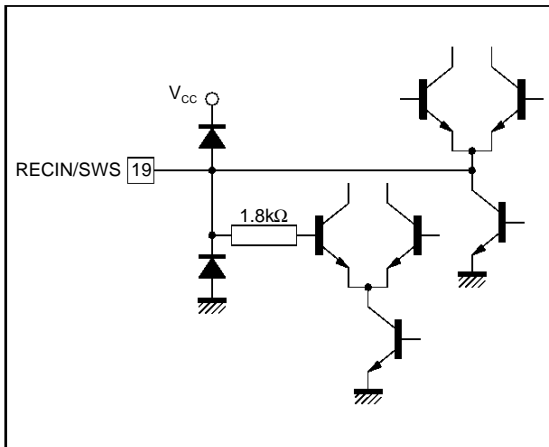

5744-13.EPS

Figure 12

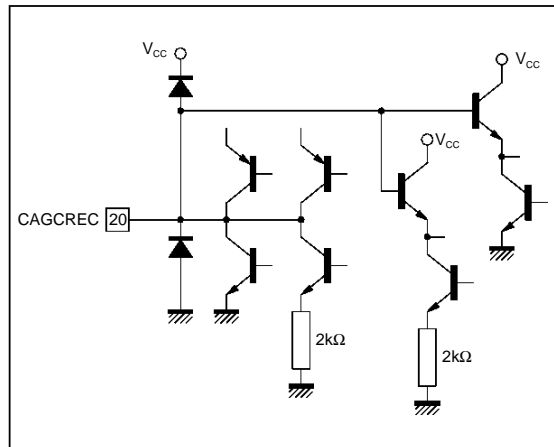

5744-14.EPS

APPLICATION DIAGRAM

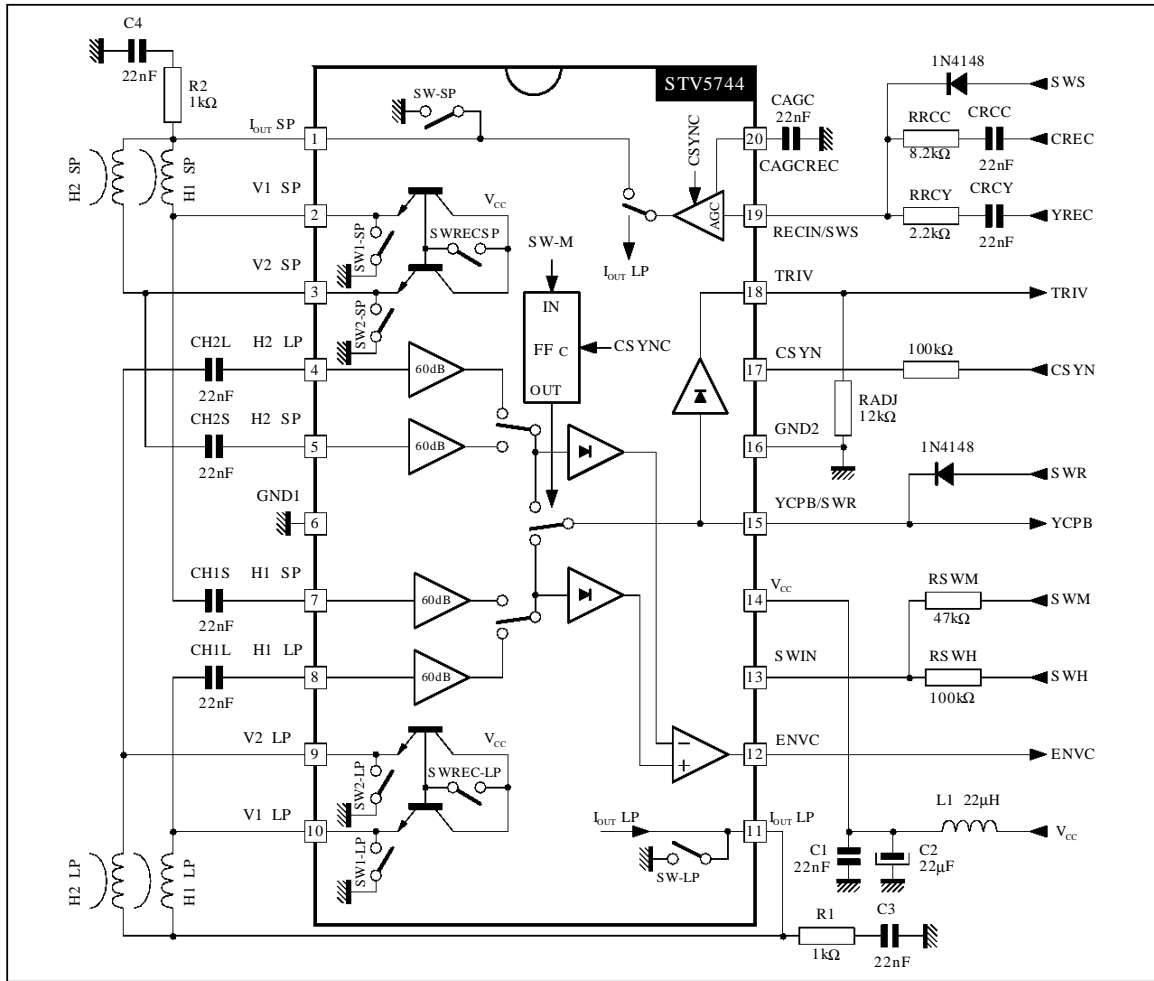

5744-03.EPS

SWITCH TABLE

SW-R	SW-M	SW-S	SW-H	Channel	SW1-SP SW2-SP	SW1-LP SW2-LP	SW-SP	SW-LP	SWREC-SP	SWREC-LP	ENVC (SPLP)	
L	L	L	L	2-SP	OFF	OFF	ON	ON	OFF	OFF	High IF LP > SP Low IF LP < SP	
			H	1-SP								
	L		1-LP									
	H		2-LP									
	L	H	L	2-SP	OFF	ON						
	H		1-SP	ON	OFF							
H	L	L	L	SP	OFF	ON	OFF	ON	ON	OFF	High	
			H	LP	ON	OFF	ON	OFF	OFF	ON		
	H		L									
			H									

5744-06.TBL

PACKAGE MECHANICAL DATA
20 PINS - PLASTIC MICROPACKAGE (SO)

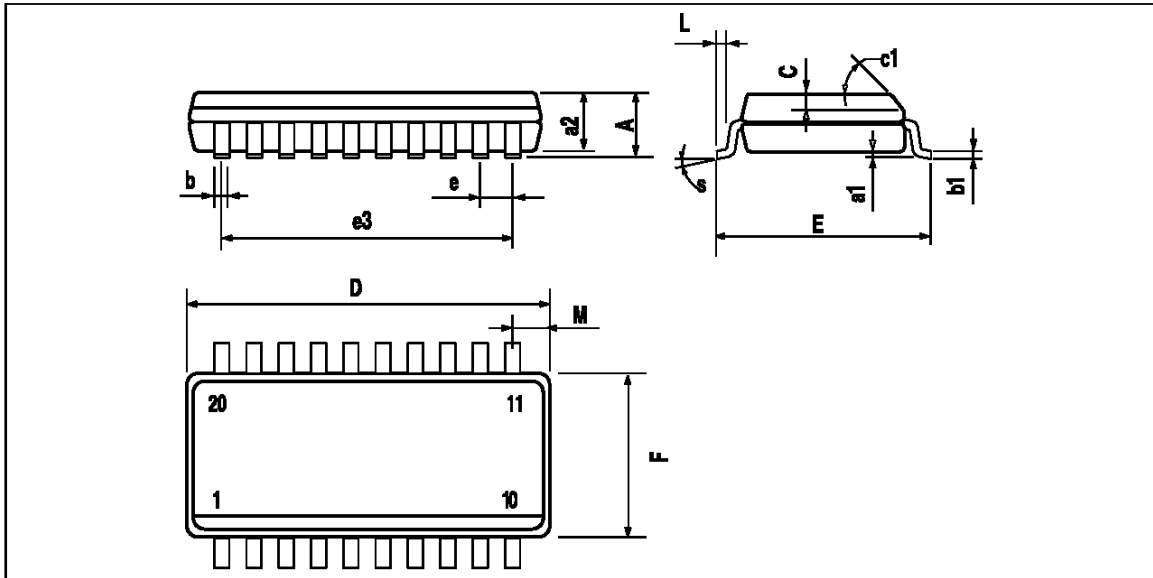

PM-SO20.EPS

Dimensions	Millimeters			Inches		
	Min.	Typ.	Max.	Min.	Typ.	Max.
A			2.65			0.104
a1	0.1		0.3	0.004		0.012
a2			2.45			0.096
b	0.35		0.49	0.014		0.019
b1	0.23		0.32	0.009		0.013
C		0.5			0.020	
c1	45° (typ.)					
D	12.6		13.0	0.496		0.512
E	10		10.65	0.394		0.419
e		1.27			0.050	
e3		11.43			0.450	
F	7.4		7.6	0.291		0.299
L	0.5		1.27	0.020		0.050
M			0.75			0.030
S	8° (Max.)					

SO20.TBL

Information furnished is believed to be accurate and reliable. However, SGS-THOMSON Microelectronics assumes no responsibility for the consequences of use of such information nor for any infringement of patents or other rights of third parties which may result from its use. No licence is granted by implication or otherwise under any patent or patent rights of SGS-THOMSON Microelectronics. Specifications mentioned in this publication are subject to change without notice. This publication supersedes and replaces all information previously supplied. SGS-THOMSON Microelectronics products are not authorized for use as critical components in life support devices or systems without express written approval of SGS-THOMSON Microelectronics.

© 1996 SGS-THOMSON Microelectronics - All Rights Reserved

Purchase of I²C Components of SGS-THOMSON Microelectronics, conveys a license under the Philips I²C Patent. Rights to use these components in a I²C system, is granted provided that the system conforms to the I²C Standard Specifications as defined by Philips.

SGS-THOMSON Microelectronics GROUP OF COMPANIES

Australia - Brazil - Canada - China - France - Germany - Hong Kong - Italy - Japan - Korea - Malaysia - Malta - Morocco
The Netherlands - Singapore - Spain - Sweden - Switzerland - Taiwan - Thailand - United Kingdom - U.S.A.