

VIDEO & SOUND IF SYSTEM

ADVANCE DATA

- VERY LOW CURRENT ABSORPTION
- 3 STAGE IF GAIN CONTROLLED AMPLIFIER
- SYNCHRONOUS VIDEO DEMODULATOR
- WHITE SPOT AND NOISE INVERTER
- AGC CIRCUIT WITH NOISE GATING
- TUNER AGC OUTPUT FOR PNP TUNERS
- FM DETECTOR
- AF AMPLIFIER WITH DC VOLUME CONTROL
- AFC
- 2 V_{PP} ON VIDEO OUTPUT

DESCRIPTION

The STV8211 is a monolithic integrated circuit in DIP20 package for black & white television receivers using PNP tuners. It is intended to operate with a negatively modulated vision carrier and frequency modulated sound carrier. Used with TEA2037A (H/V deflection circuit), this IC permits a complete low-cost solution for black and white applications.

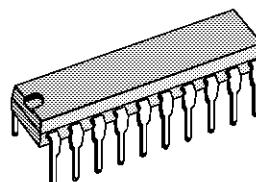

DIP20
(Plastic Package)

ORDER CODE : STV8211

PIN CONNECTIONS

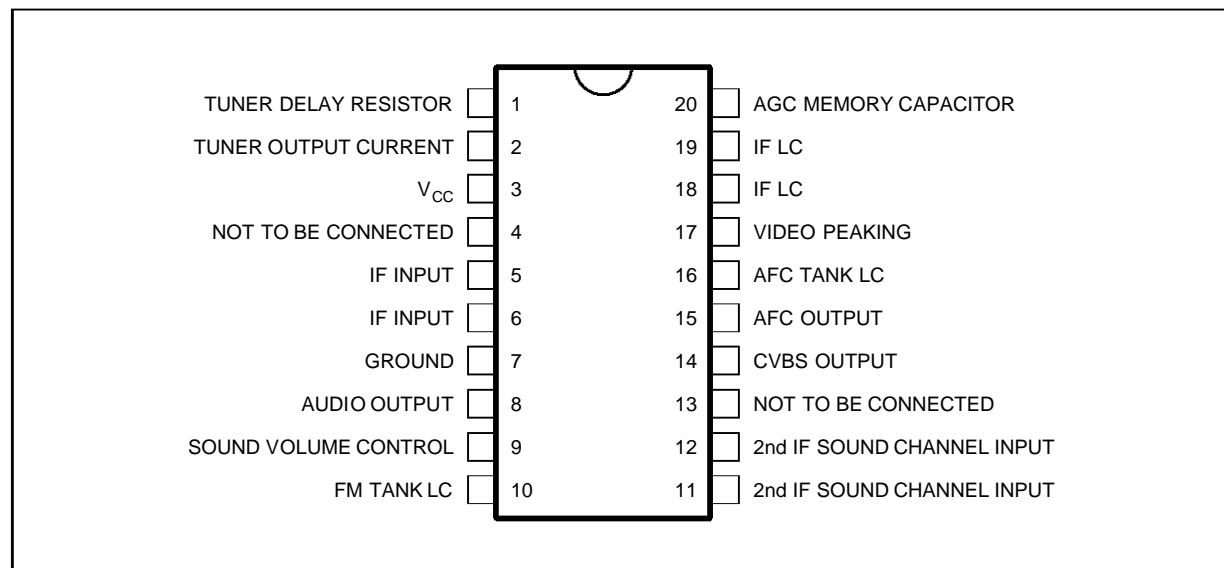

8211-01.EPS

BLOCK DIAGRAM

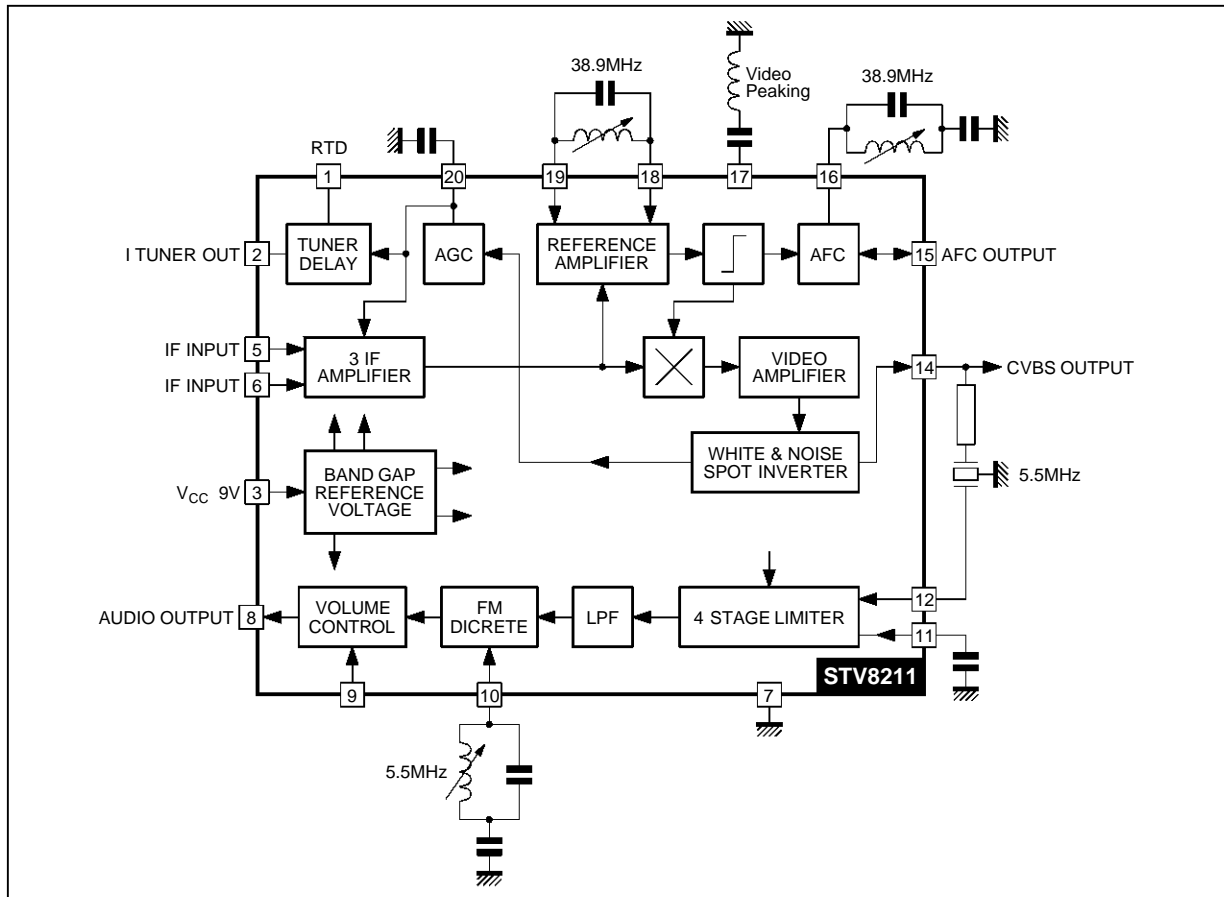

8211-02.EPS

ABSOLUTE MAXIMUM RATINGS

Symbol	Parameter	Value	Unit
V_s	Supply Voltage	13.5	V
V_x	Tuner AGC Voltage	V_s	V
P	Power Dissipation at $T_{amb} = 70^\circ\text{C}$	880	mW
T_{stg}	Storage Temperature	- 40, + 150	$^\circ\text{C}$

8211-01.TBL

THERMAL DATA

Symbol	Parameter	Value	Unit
$R_{th(j-a)}$	Junction-ambient Thermal Resistance	Max. 80	$^\circ\text{C/W}$

8211-02.TBL

ELECTRICAL CHARACTERISTICS

($T_{amb} = 25^\circ\text{C}$, $V_{cc} = 9\text{V}$, IF input = 10mV_{RMS} top sync, $D = 90\%$, Video BW = 5MHz, Sound carrier input : 5.5MHz, 10mV_{RMS} , $f_m = 1\text{kHz}$, Audio BW = 20kHz, $\Delta f = \pm 25\text{kHz}$, Volume attenuation = 0dB, unless otherwise specified)

Symbol	Parameter	Test conditions	Min.	Typ.	Max.	Unit
--------	-----------	-----------------	------	------	------	------

SUPPLY

	Supply Voltage		8	9	12.8	V
	Supply Current		14	20	28	mA

8211-03.TBL

ELECTRICAL CHARACTERISTICS

($T_{amb} = 25^{\circ}\text{C}$, $V_{CC} = 9\text{V}$, IF input = 10mV_{RMS} top sync, $D = 90\%$, Video BW = 5MHz,
Sound carrier input : 5.5MHz, 10mV_{RMS} , $f_m = 1\text{kHz}$, Audio BW = 20kHz, $\Delta f = \pm 25\text{kHz}$,
Volume attenuation = 0dB, unless otherwise specified)

Symbol	Parameter	Test conditions	Min.	Typ.	Max.	Unit
--------	-----------	-----------------	------	------	------	------

IF AMPLIFIER

	AGC Range		58	64	67	dB
	IF - Sensitivity (RMS)	Video out -3dB		70		μV
	R Input Differential	Guaranteed by process	1	1.5	2	$\text{k}\Omega$
	C Input Stray				2	pF

DEMODULATED VIDEO OUTPUT

	S/N Video (BW = 5MHz)	IF inp. = 10mV_{RMS} , $20 \log_{10} \frac{(WH - BL)}{N_{\text{RMS}}}$	49	55		dB
	Intermodulation 1.07MHz	AGC open loop, Picture carrier = 0dB, Chrominance carrier = -3.2dB, Sound carrier = -20dB		50		dB
	Detected Video Output Peak-to-peak (positive)		1.8	2	2.4	V
	Top Synchro Output Level			1.9		V
	Video Bandwidth with Output Filter	-3dB, see Figures 1 and 2		7		MHz
	Differential Phase			3	7	Degree
	Differential Gain			3	7	%
	White Noise Clamp	Referred to the video output see Figure 6		4.5		V
	White Noise Insertion			3.2		V
	Video Output Current Capability		1.2	2	2.6	mA
	Residual Output Carrier (RMS)	At 38.9MHz At 77.8MHz			10 20	mV mV

AFC

	AFC Slope	With $R_{\text{Load}} = 200\text{k}\Omega$, see Figure 3	25	40	60	mV/kHz
--	-----------	---	----	----	----	--------

AGC CIRCUIT

	Maximum I Charge		550	900	1200	μA
	Maximum I Discharge		14	20	26	μA
	$I_{\text{CH}} / I_{\text{DISCH}}$ Ratio			45		-

TUNER AGC

	Sinked Current	Suitable for Mosfet-NCH	1.15	2	2.6	mA
	Slope	RTD = $0 \div 10\text{k}\Omega$			600	$\mu\text{A}/\text{dB}$

DEMODULATED AUDIO OUTPUT

	Detected Output Audio Signal (RMS)		120	270	350	mV
	Total Harmonic Distorsion			0.5	2	%
	Amplitude Modulation Rejection	$m = 30\%$	40	53		dB
	2nd IF Sound Sensitivity -3dB FM Detected Audio Signal (RMS)			200		μV
	$\frac{S + N}{N}$	$\Delta f = \pm 25\text{kHz}$ for signal $\Delta f = 0$ after deemphasis (BW = 20kHz)	50	60		dB
	Thermal Drift of Volume			0.05		$\frac{\text{dB}}{^{\circ}\text{C}}$
	Input Resistance Limiter		400	560	720	Ω
	Volume Control versus V_g	See Figure 4		0		dB
		$V_g = 4.5\text{V}$	12	18	24	dB
		$V_g = 2.5\text{V}$	65	74		dB
		$V_g = 0.9\text{V}$				dB

8211-04.TBL

Figure 3 : AFC Voltage versus Input Frequency

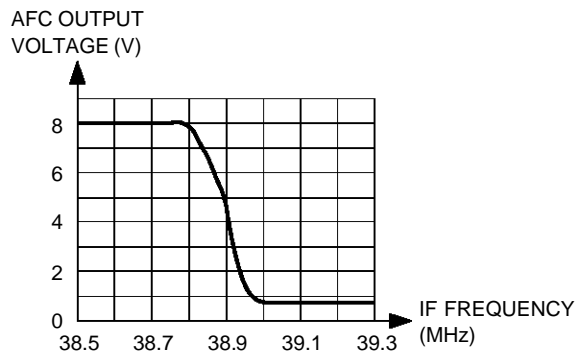

Figure 4 : Volume Control Attenuation versus Voltage in Pin 9

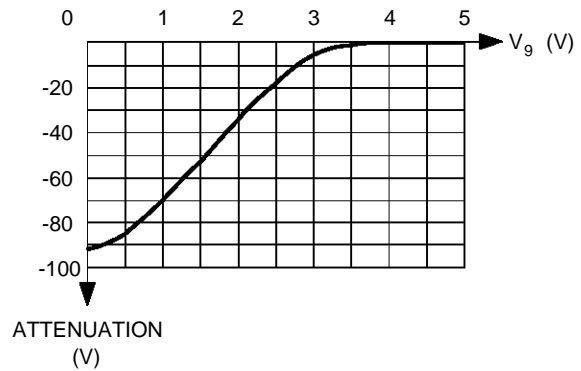

Figure 5 : Typical Connection from μP to STV8211 for Remote Volume Control (Pin 9)

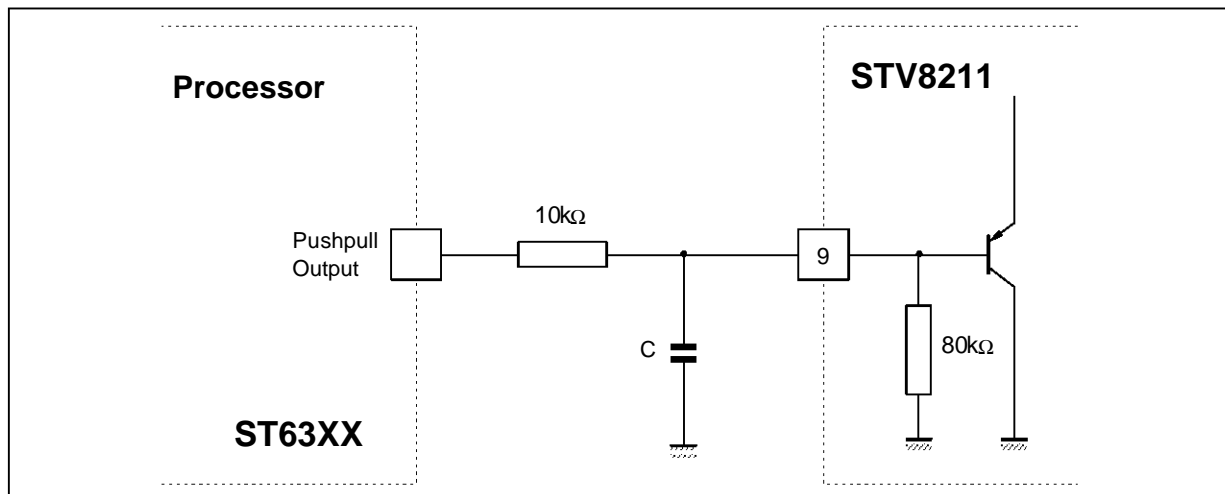

Figure 6 : Black and White Noise Inverter

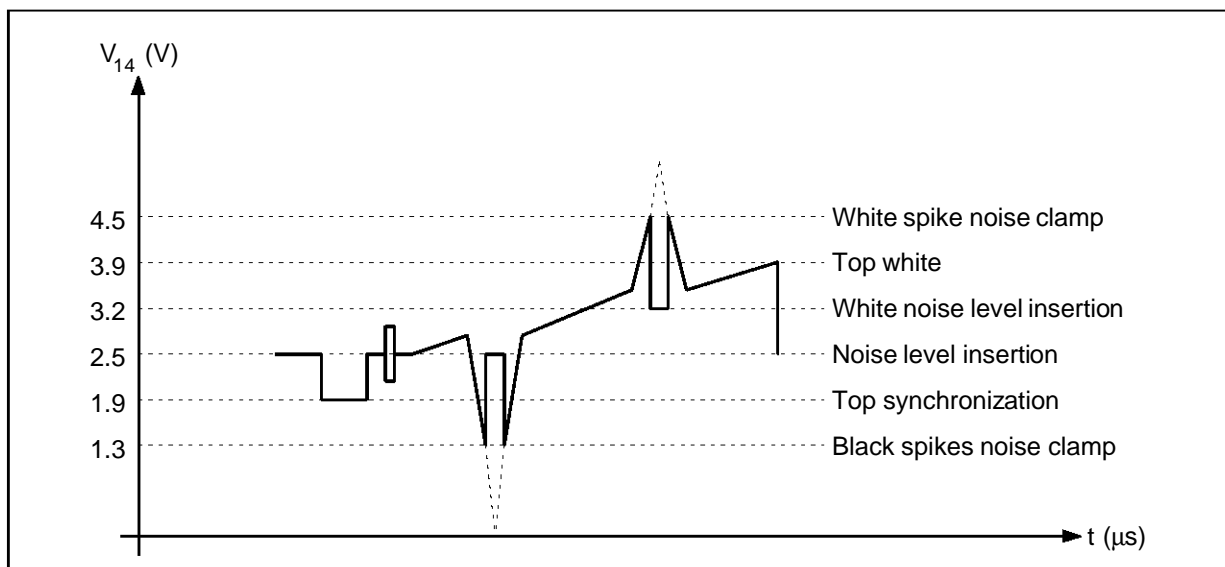
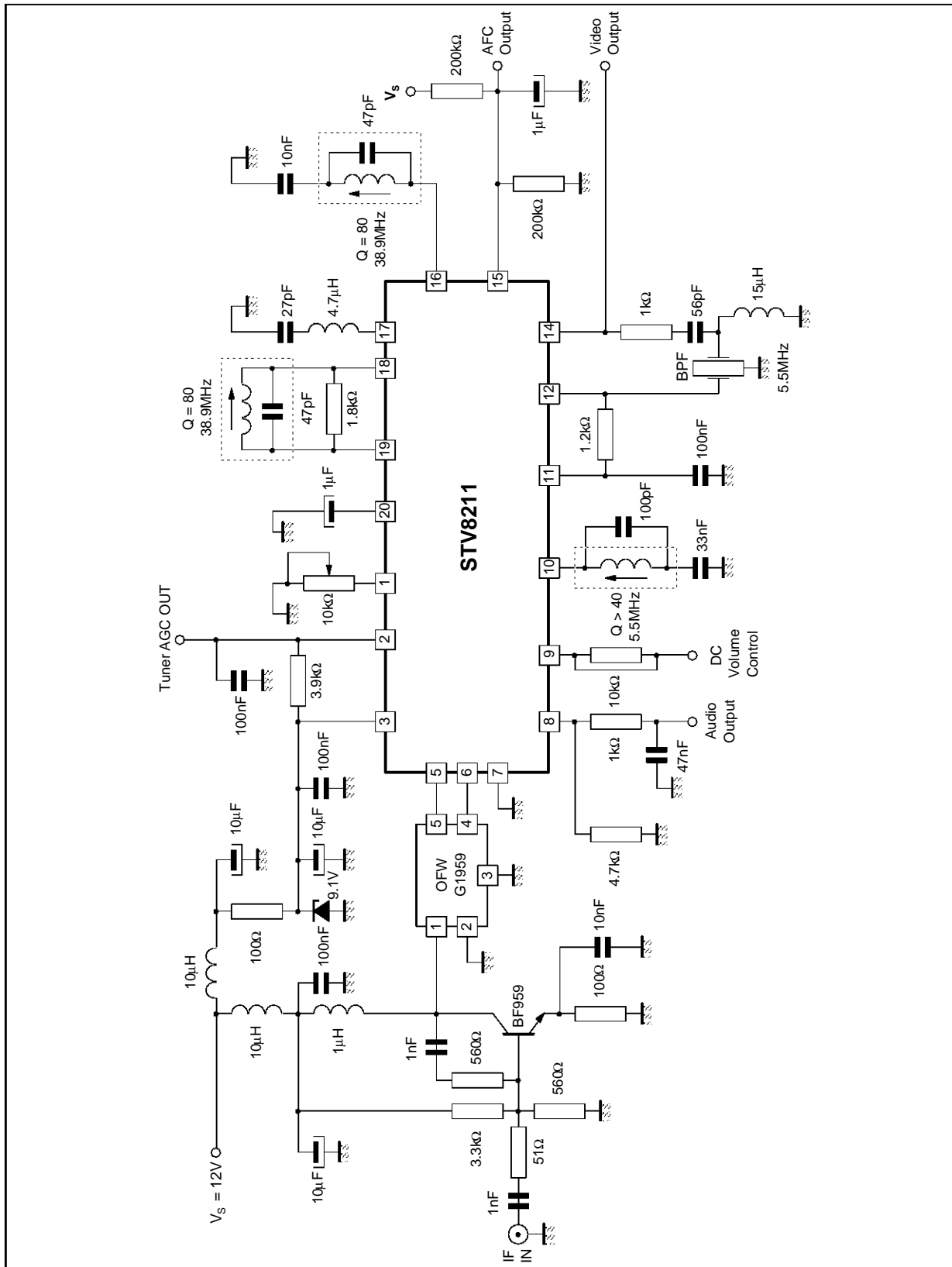

Figure 7 : Typical Application



8211-10.EPS

PACKAGE MECHANICAL DATA

20 PINS - PLASTIC DIP

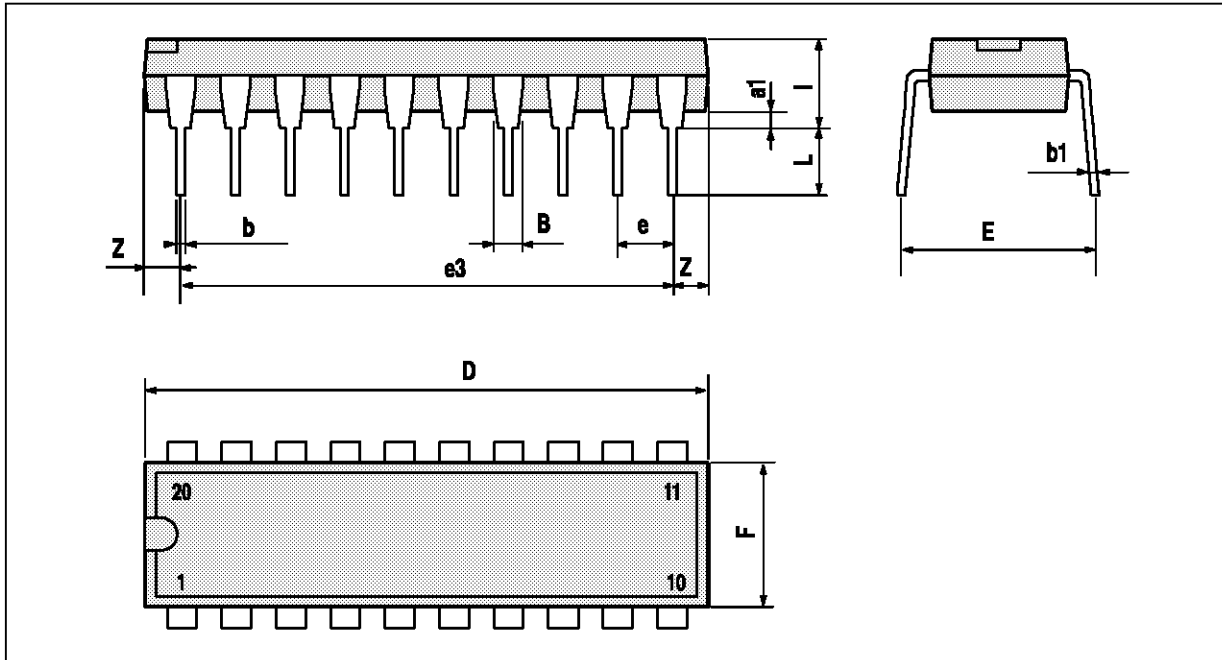

PM-DIP20.WMF

Dimensions	Millimeters			Inches		
	Min.	Typ.	Max.	Min.	Typ.	Max.
a1	0.254			0.010		
B	1.39		1.65	0.055		0.065
b		0.45			0.018	
b1		0.25			0.010	
D			25.4			1.000
E		8.5			0.335	
e		2.54			0.100	
e3		22.86			0.900	
F			7.1			0.280
i			3.93			0.155
L		3.3			0.130	
Z			1.34			0.053

DIP20.TBL

Information furnished is believed to be accurate and reliable. However, SGS-THOMSON Microelectronics assumes no responsibility for the consequences of use of such information nor for any infringement of patents or other rights of third parties which may result from its use. No licence is granted by implication or otherwise under any patent or patent rights of SGS-THOMSON Microelectronics. Specifications mentioned in this publication are subject to change without notice. This publication supersedes and replaces all information previously supplied. SGS-THOMSON Microelectronics products are not authorized for use as critical components in life support devices or systems without express written approval of SGS-THOMSON Microelectronics.

© 1994 SGS-THOMSON Microelectronics - All Rights Reserved

Purchase of I²C Components of SGS-THOMSON Microelectronics, conveys a license under the Philips I²C Patent. Rights to use these components in a I²C system, is granted provided that the system conforms to the I²C Standard Specifications as defined by Philips.

SGS-THOMSON Microelectronics GROUP OF COMPANIES

Australia - Brazil - China - France - Germany - Hong Kong - Italy - Japan - Korea - Malaysia - Malta - Morocco
The Netherlands - Singapore - Spain - Sweden - Switzerland - Taiwan - Thailand - United Kingdom - U.S.A.