

Stereo 20W (4W) Class-T Digital Audio Amplifier using Digital Power Processing™ Technology
TA2020-020

June 1999 · Preliminary

General Description

The TA2020-020 is a two-channel Class-T (Tripath™) Digital Audio Power Amplifier IC using Tripath's proprietary Digital Power Processing™ technology. Class-T amplifiers offer both the audio fidelity of Class-AB and the power efficiency of Class-D amplifiers.

Applications

- Computer/PC Multimedia
- Mini/Micro Component Systems
- Automotive Audio
- Cable Set-Top Products
- Televisions
- DVD Players
- Battery Powered Systems

Benefits

- Fully integrated solution with FETs
- Easier to design-in than Class-D
- Reduced system cost with no heat sink
- Dramatically improves efficiency versus Class AB
- Signal fidelity equal to high quality linear amplifiers
- High dynamic range compatible with digital media such as CD, DVD, and Internet audio

Features

- Class-T architecture
- Proprietary Digital Power Processing
- Single Supply Operation
- "Audiophile" Quality Sound
 - 0.04% THD+N @ 10Wrms, 4Ω
 - 0.18% IHF-IM @ 1Wrms, 4Ω
 - 8Wrms @ 8Ω, 0.1% THD+N
 - 12Wrms @ 4Ω, 0.1% THD+N
- High Power
 - 12Wrms @ 8Ω, 10% THD+N
 - 20Wrms @ 4Ω, 10% THD+N
- High Efficiency
 - 88% @ 12Wrms @ 8Ω
 - 81% @ 20Wrms @ 4Ω
- Dynamic Range = 103 dB
- Mute and Sleep inputs
- Turn-on & turn-off pop suppression
- Over-current protection
- Over-temperature protection
- Bridged outputs
- Supports 100kHz BW Super Audio CD and DVD-Audio (See App Note for specifics)
- 32-pin SSIP package

Typical Performance

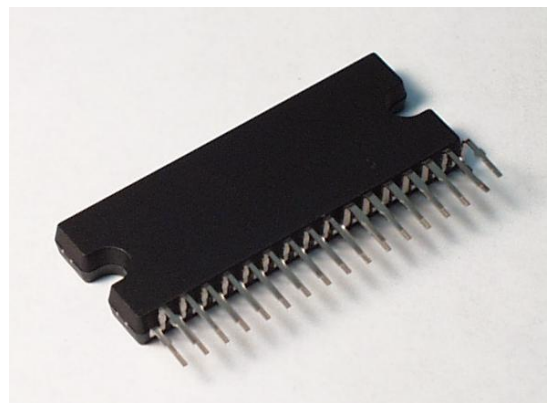
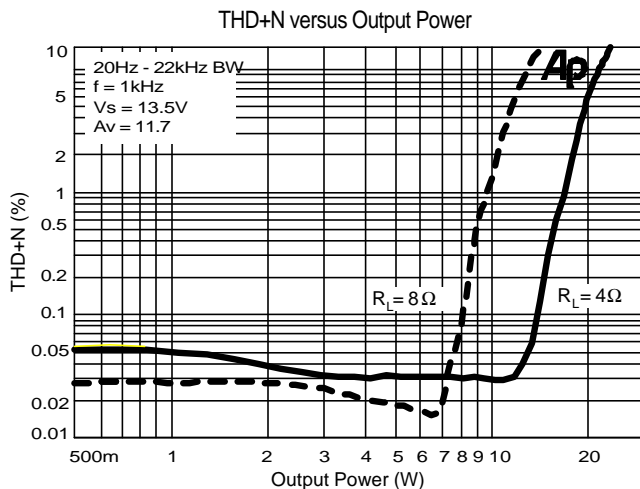

Absolute Maximum Ratings^{Note 1}

SYMBOL	PARAMETER	Value	UNITS
V _{DD}	Supply Voltage	16	V
T _{STORE}	Storage Temperature Range	-40 to 150	°C
T _A	Operating Free-air Temperature Range	0 to 70	°C
T _J	Junction Temperature	150	°C

Notes 1) Absolute Maximum Ratings indicate limits beyond which damage to the device may occur.

Operating Conditions

SYMBOL	PARAMETER	MIN.	TYP.	MAX.	UNITS
V _{DD}	Supply Voltage	8.5	13.5	14.2	V
V _{IH}	High-level Input Voltage (MUTE/IDLE, SLEEP)	3.5			V
V _{IL}	Low-level Input Voltage (MUTE/IDLE, SLEEP)			1	V

Note: Recommended Operating Conditions indicate conditions for which the device is functional. See Electrical Characteristics for guaranteed specific performance limits.

Thermal Characteristics

SYMBOL	PARAMETER	Value	UNITS
θ _{JC}	Junction-to-case Thermal Resistance	3.5	°C/W
θ _{JA}	Junction-to-ambient Thermal Resistance	15	°C/W

Pin Description

Pin	Function	Description
2, 8	V5D, V5A	Digital +5V, Analog +5V
3, 7, 16	AGND1, AGND2, AGND3	Analog Ground
4	RREF	Reference resistor
6	OVERLOADB	A logic low output indicates the input signal has overloaded the amplifier.
9, 12	VP1, VP2	Input stage feedback drive
10, 13	IN1, IN2	Single-ended inputs
11	MUTE/IDLE	When set to logic high, both amplifiers are muted and in low power (idle) mode. When low (grounded), both amplifiers are fully operational. If left floating, the device stays in the mute mode. Ground if not used.
14	BIASCAP	Bias stabilization capacitor.
17	SLEEP	When set to logic high, device goes into low power mode. If not used this pin should be grounded.
18	FAULT	A logic high output indicates thermal overload, or an output is shorted to ground or another output.
19, 28	PGND2, PGND1	Power Ground (High current)
20	DGND	Digital Ground
21, 23; 26, 24	OUTP2 & OUTM2; OUTP1 & OUTM1	Bridged outputs
22, 25	VDD2, VDD1	+13.5V Power (High Current)
1, 5, 15	NC	Not connected
27	VDDA	Analog +13.5V
29	CPUMP	Charge pump output capacitor
30	+5GEN	Regulated +5V source used to supply power to pins 3 & 8.
31, 32	DCAP2, DCAP1	Charge pump switching capacitor

32-pin SSIP Package
(Top View)

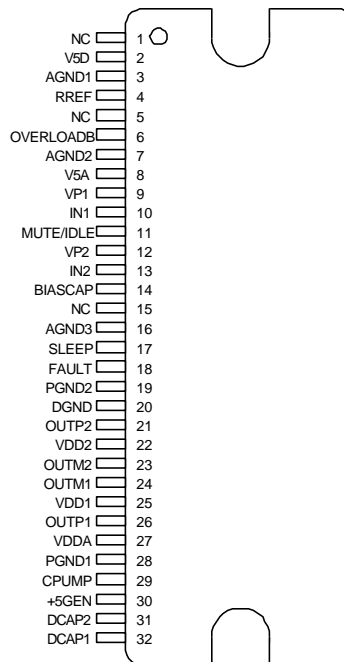

Test/Application Circuit

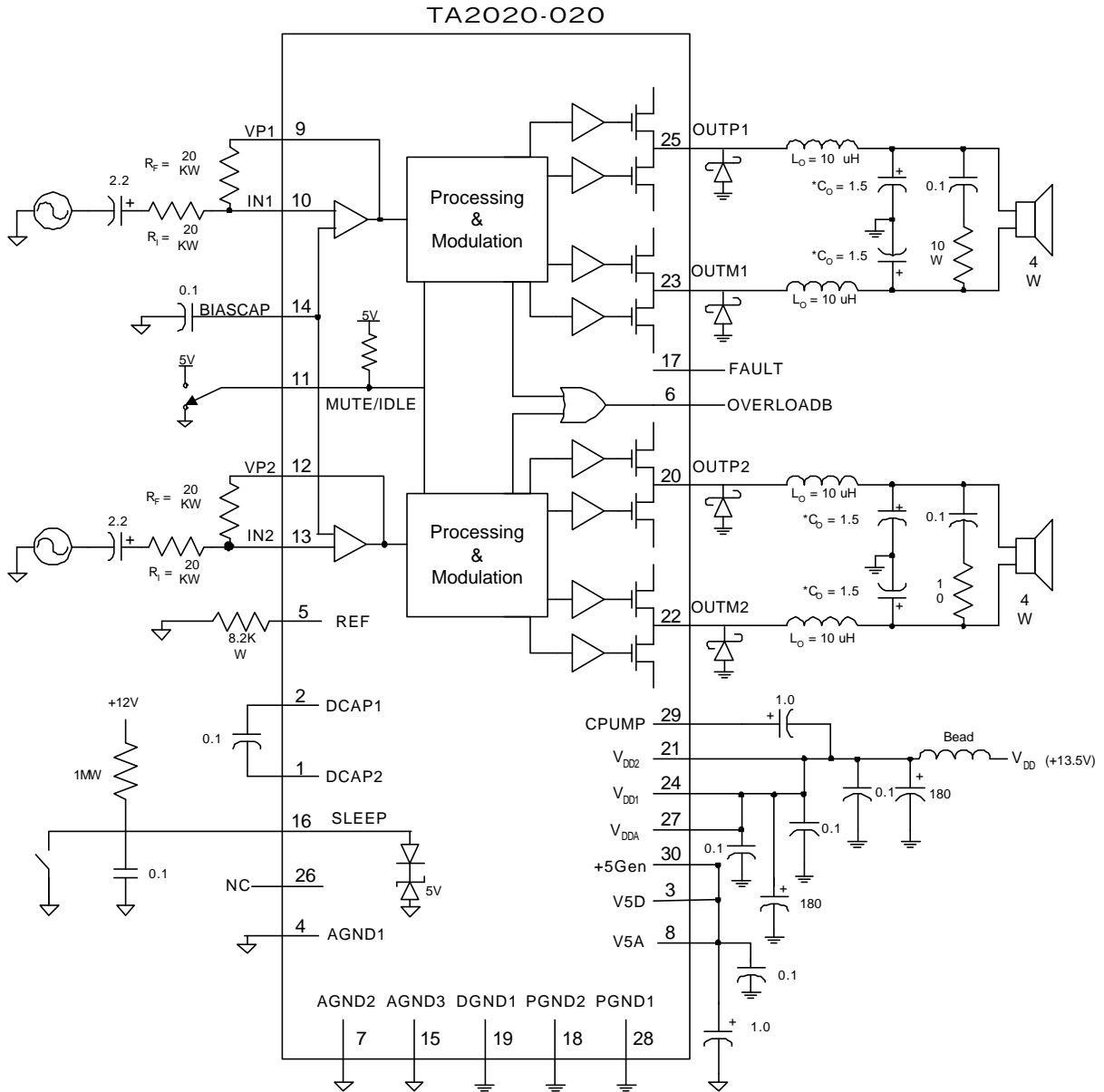

- ↕ Analog Ground
- ⊥ Digital/Power Ground
- All Diodes Motorola MBRS130T3
- All capacitance in uF
- * Use C0 = .22uF for 8 Ohm loads

Typical Performance Characteristics

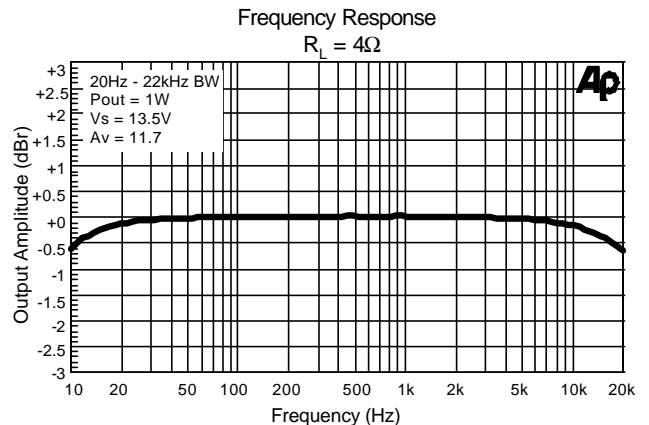
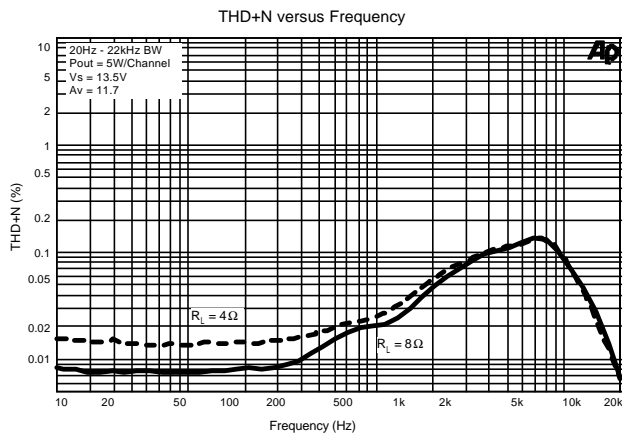
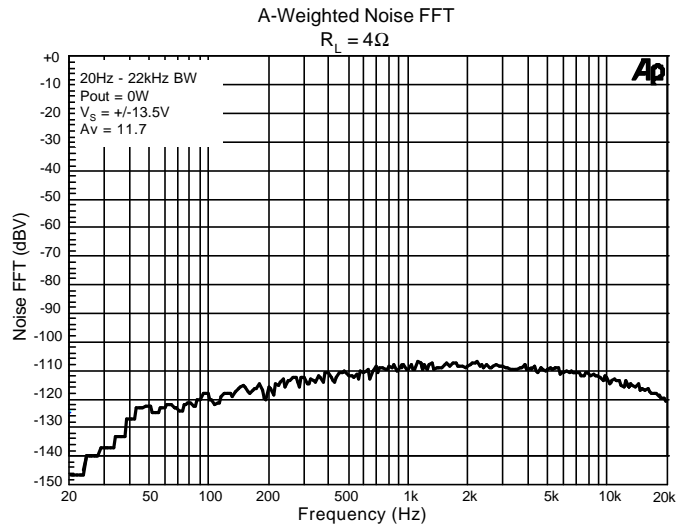
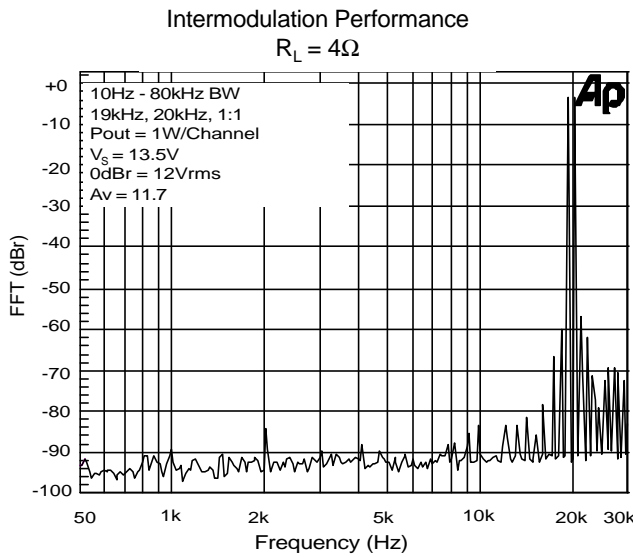
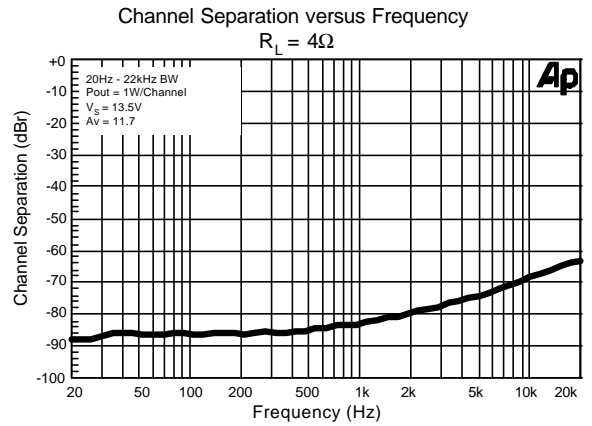
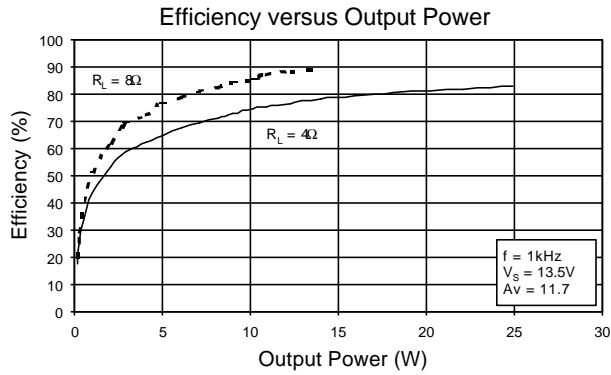

Application Information

Amplifier Gain

The gain of the TA2020-020 is set by the ratio of two external resistors, R_i and R_f , and is given by the following formula:

$$V_o/V_i = 12R_f/R_i$$

Where V_i is the input signal level and V_o is the differential output signal level across the speaker.

20 watts of RMS output power results from an 8.944 V RMS signal across a four-ohm speaker load. If $R_f = R_i$, then 20 Watts will be achieved with 0.745 V RMS of input signal.

$$8.944V \text{ RMS} = (R_L * P_o)^{1/2} = (4 \text{ ohms} * 20 \text{ Watts})^{1/2}$$

Protection Circuits

The TA2020-020 is guarded against over-temperature and over-current conditions. When the device goes into an over-temperature or over-current state, the FAULT pin goes to a logic HIGH state indicating a fault condition. When this occurs, all amplifier outputs are TRI-STATED and will float to 1/2 of V_{DD} , thereby muting the amplifier.

Over-temperature Protection

An over-temperature fault occurs if the junction temperature of the part exceeds approximately 155°C. The thermal hysteresis of the part is approximately 45°C, therefore the fault will automatically clear when the junction temperature drops below 110°C.

Over-current Protection

An over-current fault occurs if more than approximately 7 amps of current flows from any of the amplifier output pins. This can occur if the speaker wires are shorted together or if one side of the speaker is shorted to ground. An over-current fault sets an internal latch that can only be cleared if the MUTE pin is toggled or if the part is powered down. Alternately, if the MUTE pin is connected to the FAULT pin, the HIGH output of the FAULT pin will toggle the MUTE pin and automatically reset the fault condition.

Overload

The OVERLOADB pin is a 5V logic output. When low, it indicates that the level of the input signal has overloaded the amplifier resulting in increased distortion at the output. The OVERLOADB signal can be used to control a distortion indicator light or LED through a simple buffer circuit.

Sleep Pin

The SLEEP pin is a 5V logic input that when pulled high (>3.5V) puts the part into a low quiescent current mode. This pin is internally clamped by a zener diode to approximately 6V thus allowing the pin to be pulled up through a large valued resistor (1M Ω recommended) to V_{DD} . To disable SLEEP mode, the sleep pin should be grounded.

Fault Pin

The FAULT pin is a 5V logic output that indicates various fault conditions within the device. These conditions include: low supply voltage, low charge pump voltage, low 5V regulator voltage, over current at any output, and junction temperature greater than approximately 155°C. The FAULT output is capable of directly driving an LED through a series 200-Ohm resistor. If the FAULT pin is connected directly to the MUTE input an automatic reset will occur in the event of an over-current condition.

Heat Sink Requirements

In some applications it may be necessary to fasten the TA2020-020 to a heat sink. The determining factor is that the 150°C maximum junction temperature, $T_j(\text{max})$ cannot be exceeded, as specified by the following equation:

$$P_{DISS} = (T_j(\text{max}) - T_A)/\theta_{JA}$$

Example:

What size heat sink is required to operate the TA2020-020 at 20W per channel continuously in a 70°C ambient temperature?

P_{DISS} is determined by:

$$\text{Efficiency} = \eta = P_{OUT}/P_{IN} = P_{OUT}/(P_{OUT} + P_{DISS})$$

$$P_{DISS} \text{ (Per channel)} = P_{OUT}/\eta \cdot P_{OUT} = 20/80\% \cdot 20 = 5W$$

$$P_{DISS} \text{ (For two channels)} = 10W$$

$$\theta_{JA} = (T_J(\text{max}) - T_A)/P_{DISS} = (150 - 70)/10 = 8^\circ\text{C/W}$$

The θ_{JA} of the TA2020-020 in free air is 15°C/W. The θ_{JC} of the TA2020-020 is 3.5°C/W, so a heat sink of 4.5°C/W is required for this example. In actual applications, other factors such as the average P_{DISS} with a music source (as opposed to a continuous sine wave) and regulatory agency testing requirements will determine the size of the heat sink required.

Circuit Board Layout

The TA2020-020 is a power (high current) amplifier that operates at relatively high switching frequencies. Therefore, the outputs of the amplifier switch between the supply voltage and ground at high speeds while driving high currents. This high-frequency digital signal is passed through an LC low-pass filter to recover the amplified audio signal. Since the amplifier must drive the inductive LC output filter and speaker loads, the amplifier outputs can be pulled above the supply voltage and below ground by the energy in the output inductance. To avoid subjecting the TA2020-020 to potentially damaging voltage stress, it is critical to have a good printed circuit board layout. It is recommended that Tripath's layout and application circuit be used for all applications and only be deviated from after careful analysis of the effects of any changes.

Performance Measurements of the TA2020-020

Tripath amplifiers operate by generating a high frequency switching pattern based on the input signal. This signal is sent through a low-pass filter (external to the Tripath amplifier) that recovers an amplified version of the audio input. The frequency of the switching pattern is spread spectrum and typically varies between 100kHz and 1.0MHz, which is well above the 20Hz – 20kHz audio band. The pattern itself does not alter or distort the audio input signal but it does introduce some inaudible components.

The measurements of certain performance parameters, particularly noise related specifications such as THD+N, are significantly affected by the design of the low-pass filter used on the output as well as the bandwidth setting of the measurement instrument used. Unless the filter has a very sharp roll-off just beyond the audio band or the bandwidth of the measurement instrument is limited, some of the inaudible noise components introduced by the Tripath amplifier switching pattern will degrade the measurement.

One feature of Tripath amplifiers is that they do not require large multi-pole filters to achieve excellent performance in listening tests, usually a more critical factor than performance measurements. Though using a multi-pole filter may remove high-frequency noise and improve THD+N type measurements (when they are made with wide-bandwidth measuring equipment), these same filters degrade frequency response. The TA2020-020 Evaluation Board uses the Test/Application Circuit of this data sheet, which has a simple two-pole output filter and excellent performance in listening tests. Measurements in this data sheet were taken using this same circuit with a limited bandwidth setting in the measurement instrument.

Package Information

32-pin SSIP Package:

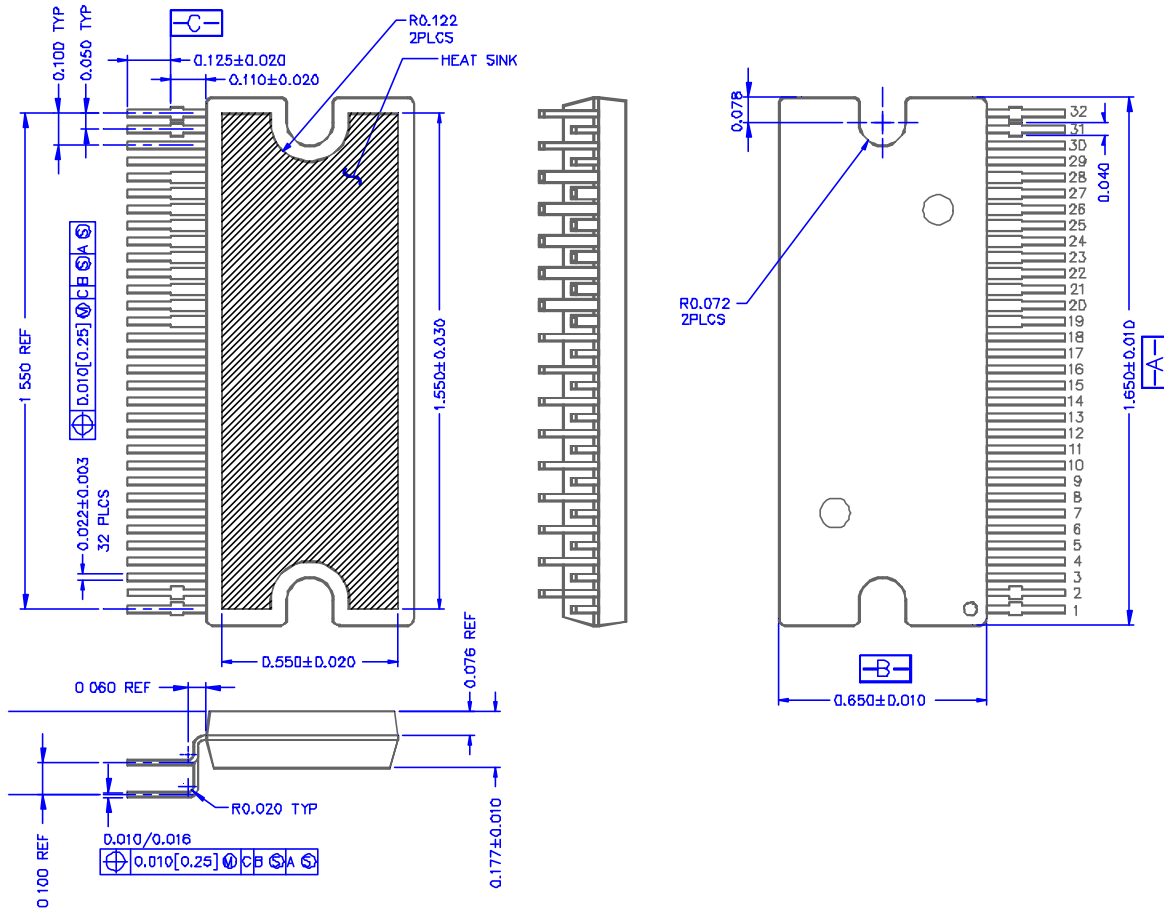

ADVANCED INFORMATION – This is a product in development. Tripath Technology Inc. reserves the right to make any changes without further notice to improve reliability, function or design.

Tripath and Digital Power Processing are trademarks of Tripath Technology Inc. Other trademarks referenced in this document are owned by their respective companies.

Tripath Technology Inc. reserves the right to make changes without further notice to any products herein to improve reliability, function or design. Tripath does not assume any liability arising out of the application or use of any product or circuit described herein; neither does it convey any license under its patent rights, nor the rights of others.

TRIPATH'S PRODUCTS ARE NOT AUTHORIZED FOR USE AS CRITICAL COMPONENTS IN LIFE SUPPORT DEVICES OR SYSTEMS WITHOUT THE EXPRESS WRITTEN CONSENT OF THE PRESIDENT OF TRIPATH TECHNOLOGY INC. As used herein:

1. Life support devices or systems are devices or systems which, (a) are intended for surgical implant into the body, or (b) support or sustain life, and whose failure to perform, when properly used in accordance with instructions for use provided in this labeling, can be reasonably expected to result in significant injury to the user.
2. A critical component is any component of a life support device or system whose failure to perform can be reasonably expected to cause the failure of the life support device or system, or to affect its safety or effectiveness.

TRIPATH TECHNOLOGY INC.
3900 Freedom Circle
Santa Clara, California 95054
408-567-3000.
www.Tripath.com