

TOSHIBA CMOS DIGITAL INTEGRATED CIRCUIT SILICON MONOLITHIC

TC9172AP, TC9227P, TC9228P

HIGH SPEED PLL WITH BUILT-IN PRESCALER

TC9172AP, TC9227P and TC9228P are high-speed PLL-LSI developed for digital tuning system use, and contain 2-modulus prescaler.

When they are used in combination with system controller LSI TC9301AN, TC9302AF, TC9303AN, TC9306F series, high performance digital synthesized tuner can be realized.

FEATURES

- They contain prescaler, and can directly input the frequency signal of 120MHz max. at FM band.
- Either pulse swallow dividing type or direct dividing type can be applied depending upon receiving band.
- Both high function type (DIP22 pin) and conventional type (DIP16 pin) are provided.
High function type contains IF counter which counts IF signal at FM/AM band each and produces auto-stop signal.
- Reference frequency is supplied from the controller LSI, and no crystal oscillator is required on the PLL LSI.
- They have two phase comparator outputs, and can use two kinds of low pass filters without changing.
- Abundant general purpose input-output terminals make possible the control of radio frequency circuit part.
- Frequency input terminals are provided for FM and AM, independently.
- IF offset can be easily controlled at FM band.
- As serial ports are contained, control of all functions including frequency division number setting is performed through four serial bus lines.

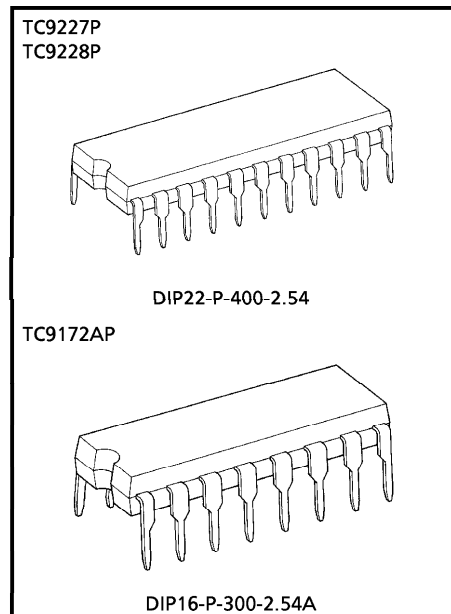

Weight
 DIP22-P-400-2.54 : 2.1g (Typ.)
 DIP16-P-300-2.54A : 1.0g (Typ.)

980910EBA2

- TOSHIBA is continually working to improve the quality and the reliability of its products. Nevertheless, semiconductor devices in general can malfunction or fail due to their inherent electrical sensitivity and vulnerability to physical stress. It is the responsibility of the buyer, when utilizing TOSHIBA products, to observe standards of safety, and to avoid situations in which a malfunction or failure of a TOSHIBA product could cause loss of human life, bodily injury or damage to property. In developing your designs, please ensure that TOSHIBA products are used within specified operating ranges as set forth in the most recent products specifications. Also, please keep in mind the precautions and conditions set forth in the TOSHIBA Semiconductor Reliability Handbook.
- The products described in this document are subject to the foreign exchange and foreign trade laws.
- The information contained herein is presented only as a guide for the applications of our products. No responsibility is assumed by TOSHIBA CORPORATION for any infringements of intellectual property or other rights of the third parties which may result from its use. No license is granted by implication or otherwise under any intellectual property or other rights of TOSHIBA CORPORATION or others.
- The information contained herein is subject to change without notice.

PIN CONNECTION (TOP VIEW)

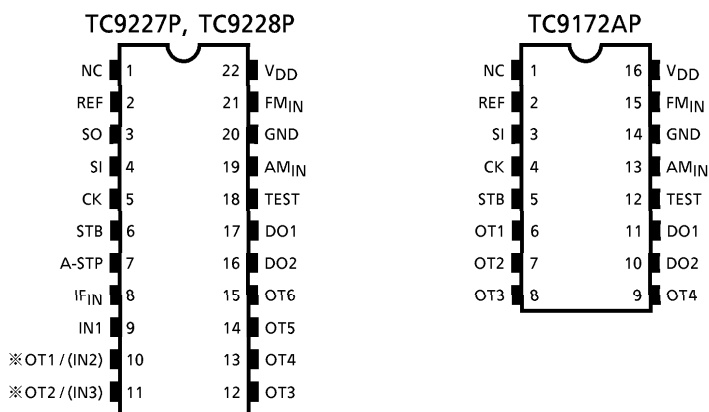

(Note) ※ Bracketed letters indicate TC9228P terminal name.
Others indicate common terminals.

VERSION TABLE

PRODUCTION NAME	TC9172AP	TC9227P	TC9228P
Package	DIP16 pin	DIP22 pin	DIP22 pin
Process	Silicon CMOS gate		
Frequency Dividing Type	Pulse swallow and direct dividing type		
Serial Port	○	○	○
Input Port	—	2	4
Output Port	4	6	4
IF Counter	—	○	○
Phase Comparator Output	2	2	2
Supply Voltage	5V ± 10% single power supply		

BLOCK DIAGRAM

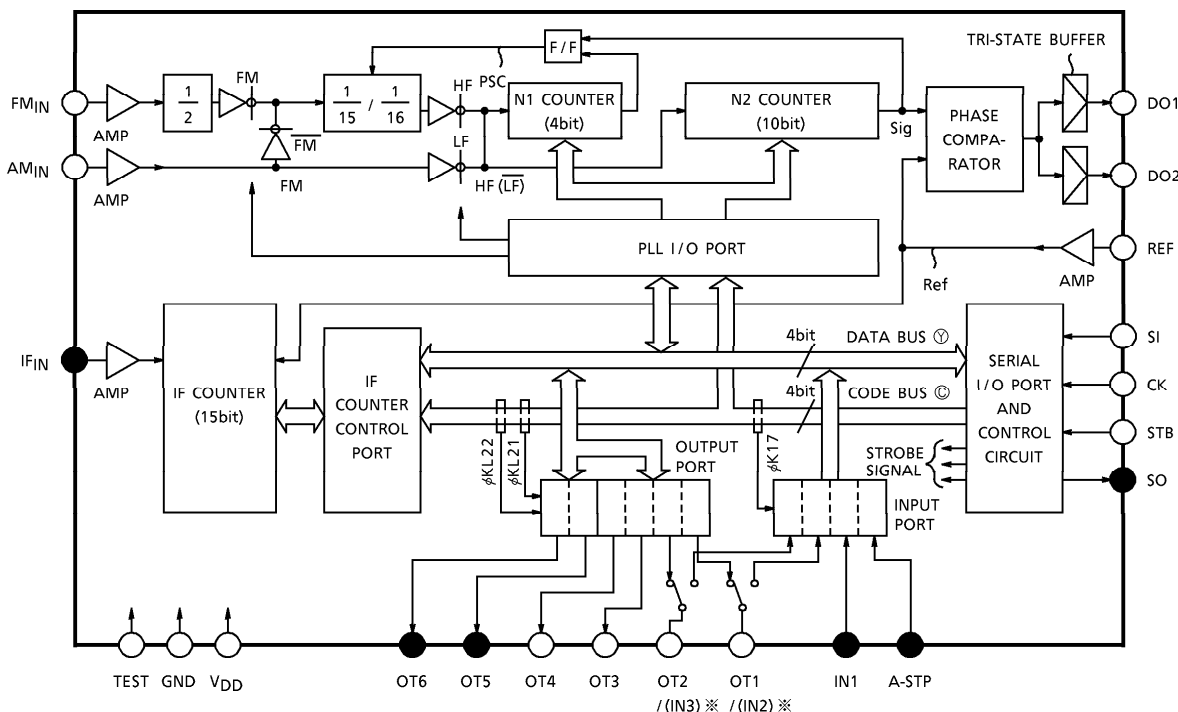

(Note) ※ Bracketed letters indicate TC9228P terminal name.
 ● Terminal does not exist in TC9172AP.

PIN FUNCTION

() : Terminal of TC9172AP

PIN No.	SYMBOL	PIN NAME	EXPLANATION OF FUNCTIONS AND OPERATIONS	REMARKS
1, (1)	NC	No connection	—	—
2, (2)	REF	Reference frequency input	Input of reference frequency signal supplied from controller LSI. Bilt-in Amp. C coupling small amplitude operation.	
3, (—)	SO	Serial output	Serial I/O ports. Carries out between controller the setting of frequency dividing number, dividing type, and the transfer of data for controlling IF counter, general purpose I/O ports. As TC9172AP has no serial output mode. SO terminal does not exist. SO terminal is P-ch open drain output, and SI, CK, STB terminals are Schmitt trigger inputs.	
4, (3)	SI	Serial input		
5, (4)	CK	Clock signal input		
6, (5)	STB	Strobe signal input		

PIN No.	SYMBOL	PIN NAME	EXPLANATION OF FUNCTIONS AND OPERATIONS	REMARKS
7, (—)	A-STP	Auto stop input	Inputs auto stop signal. It can be used as general purpose input port also. (TC9227P, TC9228P)	
8, (—)	IF _{IN}	IF signal input	IF signal input of IF counter to detect auto stop. Built-in Amp. C coupling small amplitude operation (TC9227P, TC9228P).	
9, (—)	IN1	General purpose input port	Freely usable general purpose input terminal (TC9227P, TC9228P)	
10, (6)	OT1 ※ (IN2)	General purpose output ports	Freely usable general purpose output terminals. They can be used for switching control signal output of radio frequency circuit. <ul style="list-style-type: none"> ● TC9172AP : 4 ● TC9227P : 6 ● TC9228P : 4 (Note) ※ In TC9228P, 10, 11 pins are indicated as input port.	
11, (7)	OT2 ※ (IN3)			
12, (8)	OT3			
13, (9)	OT4			
14, (—)	OT5			
15, (—)	OT6			
16, (10)	DO2	Phase comparator outputs	Tri-state outputs of phase comparator. DO1, DO2 are parallel outputs.	
17, (11)	DO1			
18, (12)	TEST	Test terminal	Test mode control input. With pull-down resistance. Usually, used in OPEN state or GND connected.	
19, (13)	AM _{IN}	AM local oscillator signal input	Programmable counter input at AM band. Built-in Amp. C coupling small amplitude operation.	
21, (15)	FM _{IN}	FM local oscillator signal input	Prescaler input at FM band. f _{MAX} = 120MHz Built-in Amp. C coupling small amplitude operation.	
22, (16)	V _{DD}	Power supply terminal	Supply 5V ± 10%	—
20, (14)	GND			

I/O MAP

● TC9227P, TC9228P I/O MAP

CODE	I/O	PLL (1)				GENERAL PURPOSE OUTPUT (2)			
		Y1	Y2	Y4	Y8	Y1	Y2	Y4	Y8
INPUT PORT (K)	0	Programmable counter dividing type setting							
		HF	$\Delta IF + 1$	$\Delta IF - 1$	FM				
	1	Programmable counter dividing number setting				General purpose output			
		P0	P1	P2	P3	OT1	OT2	OT3	OT4
	2	Same as above				General purpose output			
		P4	P5	P6	P7	OT5	OT6		
	3	Same as above							
		P8	P9	P10	P11				
	4	Same as above							
		P12	P13						
5									
6	IF counter control								
	BUSY	WIDE	STOP						
7	General purpose input								
	A-STP	IN1	IN2	IN3					
OUTPUT PORT (L)	8	Programmable counter dividing type setting							
		HF	$\Delta IF + 1$	$\Delta IF - 1$	FM				
	9	Programmable counter dividing number setting				General purpose output			
		P0	P1	P2	P3	OT1	OT2	OT3	OT4
	A	Same as above				General purpose output			
		P4	P5	P6	P7	OT5	OT6		
	B	Same as above							
		P8	P9	P10	P11				
	C	Same as above							
		P12	P13						
D	REF code data								
	1	2	4						
E	IF counter control								
	START	WIDE	RESET						
F	Chip select code data "1"				Chip select code data "2"				
	1	0	0	0	0	1	0	0	

● TC9172AP I/O MAP

CODE	I/O	PLL (1)				GENERAL PURPOSE OUTPUT (2)																		
		Y1	Y2	Y4	Y8	Y1	Y2	Y4	Y8															
INPUT PORT (K)	0	/				/																		
	1																							
	2																							
	3																							
	4																							
	5																							
	6																							
	7																							
OUTPUT PORT (L)	8	Programmable counter dividing type setting				/																		
		HF	$\Delta IF + 1$	$\Delta IF - 1$	FM																			
	9	Programmable counter dividing number setting								General purpose output														
		P0	P1	P2	P3					OT1	OT2	OT3	OT4											
	A	Same as above								/														
		P4	P5	P6	P7																			
	B	Same as above												/										
		P8	P9	P10	P11																			
	C	Same as above																/						
		P12	P13																					
D	/				/																			
E																								
F									Chip select code data "1"													Chip select code data "2"		
	1	0	0	0					0													1	0	0

(Note) TC9172AP contains no input port.
As it contains IF counter, there is no control port of it.

TEST CIRCUIT

TC9227P, TC9228P

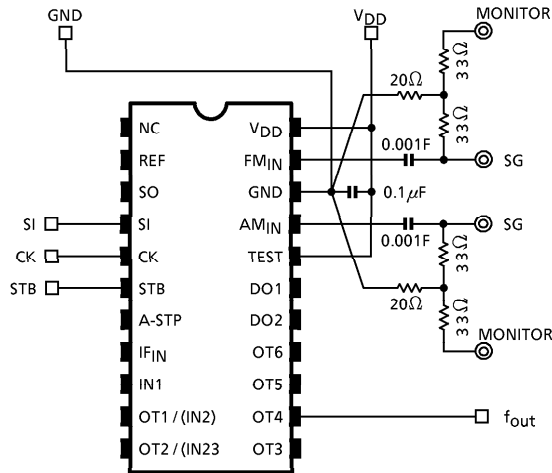

TC9172AP

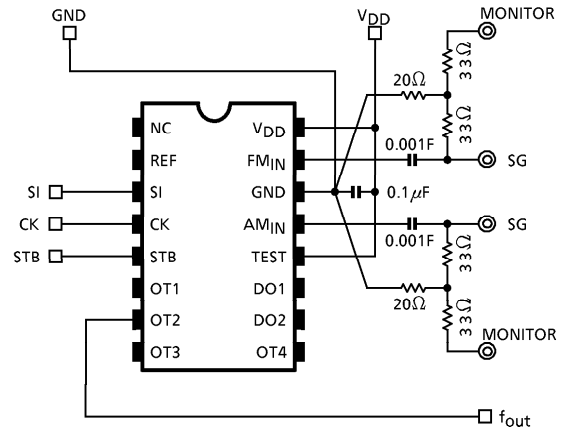

EXAMPLE FOR APPLICATION CIRCUIT

(TC9227P)

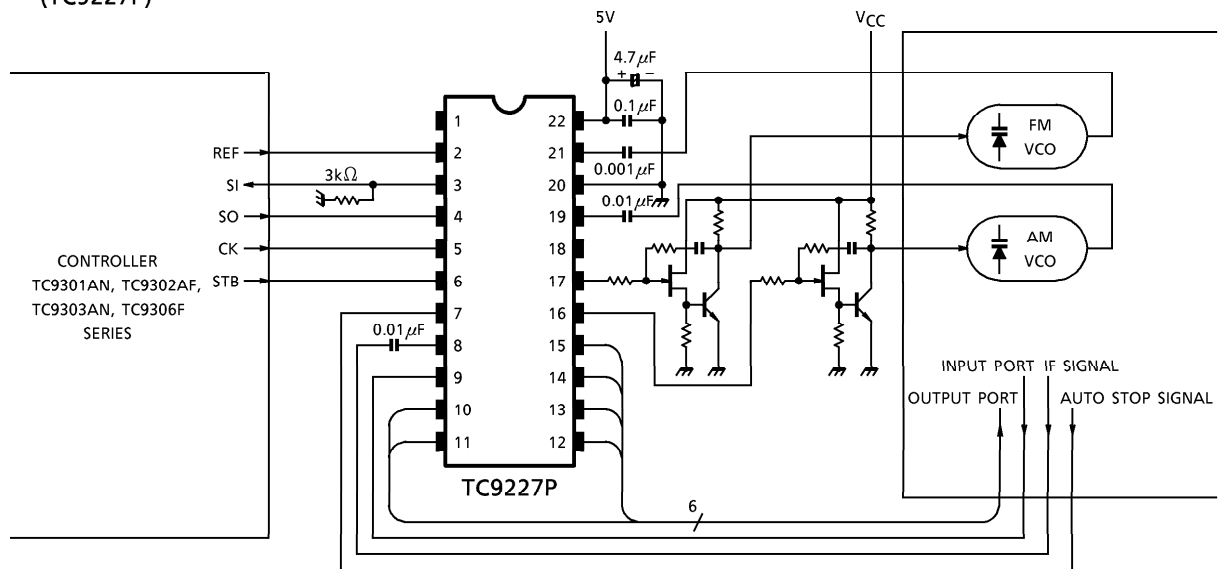

OUTLINE DRAWING
DIP22-P-400-2.54

Unit : mm

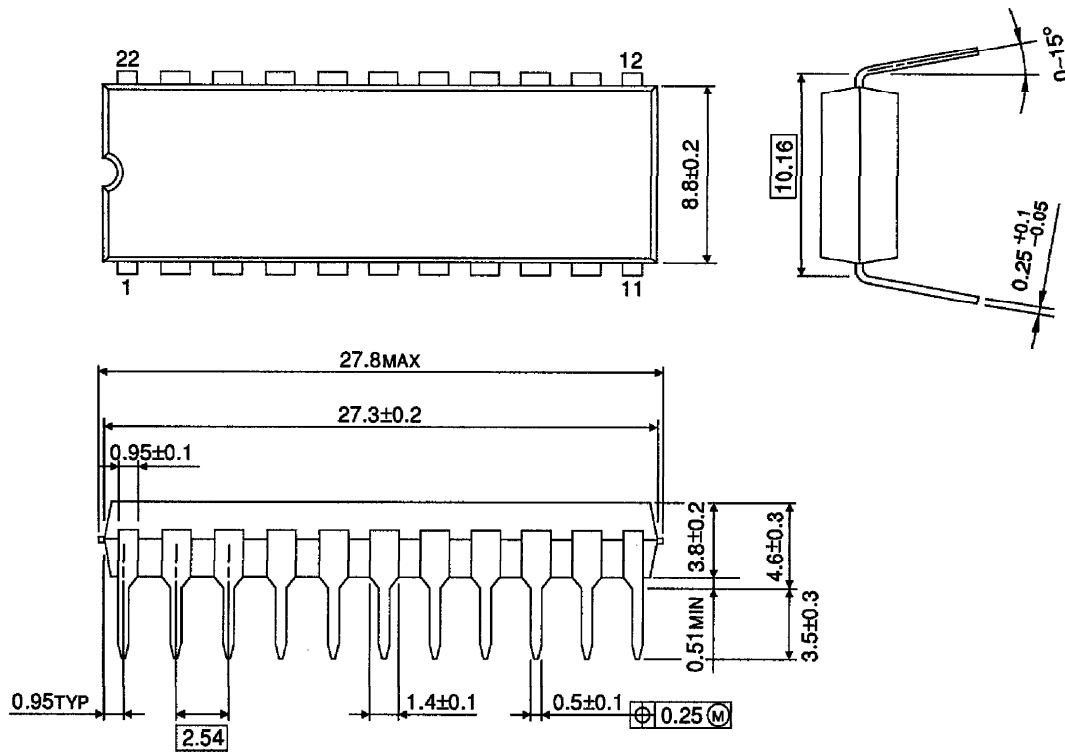

Weight : 2.1g (Typ.)

OUTLINE DRAWING
DIP16-P-300-2.54A

Unit : mm

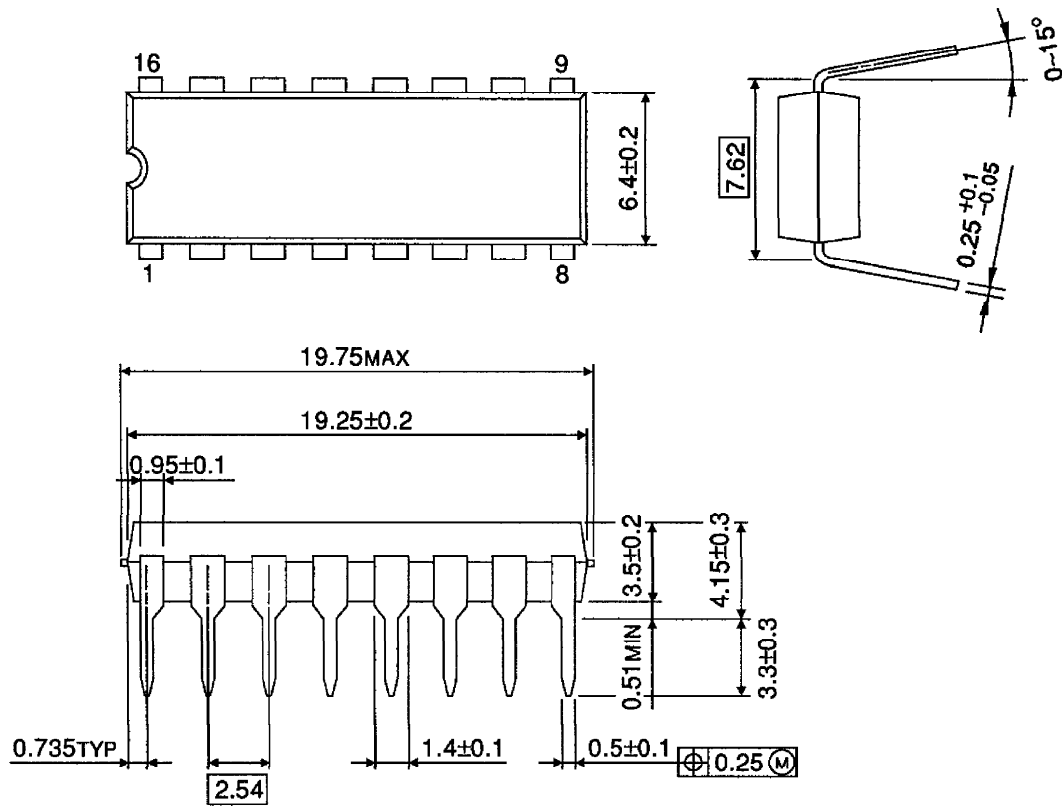

Weight : 1.0g (Typ.)