

MULTISTANDARD VIDEO IF SYSTEM

PRELIMINARY DATA

- MULTISTANDARD VIDEO IF (POSITIVE AND NEGATIVE MODULATION)
- WHITE SPOT INVERTER AND NOISE SUPPRESSOR
- HIGH INPUT SENSITIVITY
- VERY LOW SENSITIVITY OF VISION OUTPUT AMPLITUDE VERSUS TEMPERATURE AND V_{CC}
- VERY LOW DIFFERENTIAL PHASE AND GAIN
- VERY LOW SENSITIVITY TO THE DETUNING OF THE IF VIDEO CARRIER
- HIGH STABILITY OF THE TUNER AGC CURRENT

DESCRIPTION

The TDA8123A is a multistandard B/G and L video IF demodulator consisting of three AC coupled IF stages with more than 60dB AGC range, flat amplitude/frequency response from 10 to 85 MHz and linearized phase slope from 30 to 50MHz.

Video carrier regeneration is performed by a tuned reference amplifier and a wide band limiter increasing the linearity, the differential phase and gain and reducing the sensitivity to the detuning of the 38.9MHz coil.

The carrier is then applied to the video demodulator through a special circuit which switches the carrier phase from 0° to 180° so that the video polarity can be maintained constant when the standard switches from B/G to L.

A noise inverter and a white spot inverter are included in order to eliminate ultra-black and white pulses. The last one can be disabled applying a voltage higher than 2V at Pin7.

The video output is applied also to the AGC circuit that performs a top sync or a top white clamp, implemented by two double comparators, and reconstructs the DC video components in accordance with the two different standards. The voltage at the output of the two comparators is memorized by an external capacitor and used to drive the AGC network, which allows an input regulation of the video carrier from less than $100\mu V$ to 100mV.

The integrated circuit is completed by a delayed control storage with current output for the tuner AGC. This current has a very low sensitivity to temperature variations.

The TDA8123A includes also a block for the standard switching (standard B/G or standard L) controlled by a TTL compatible input.

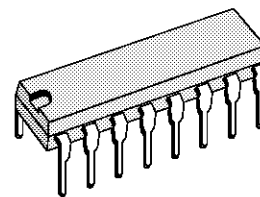

DIP16
(Plastic Package)

ORDER CODE : TDA8123A

PIN CONNECTIONS

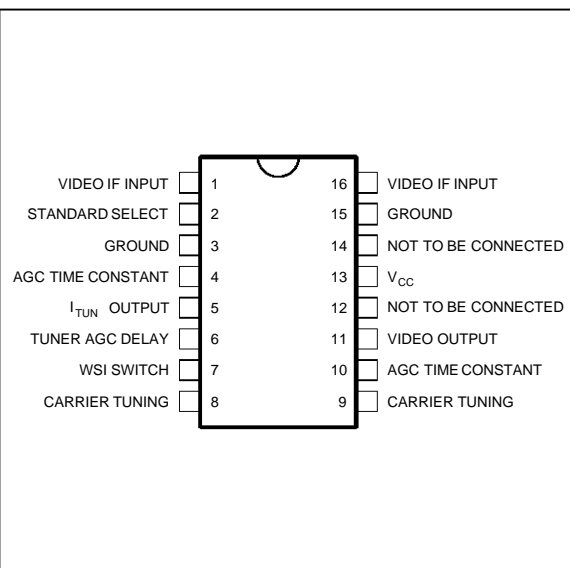

8123A-01.EPS

TDA8123A

BLOCK DIAGRAM

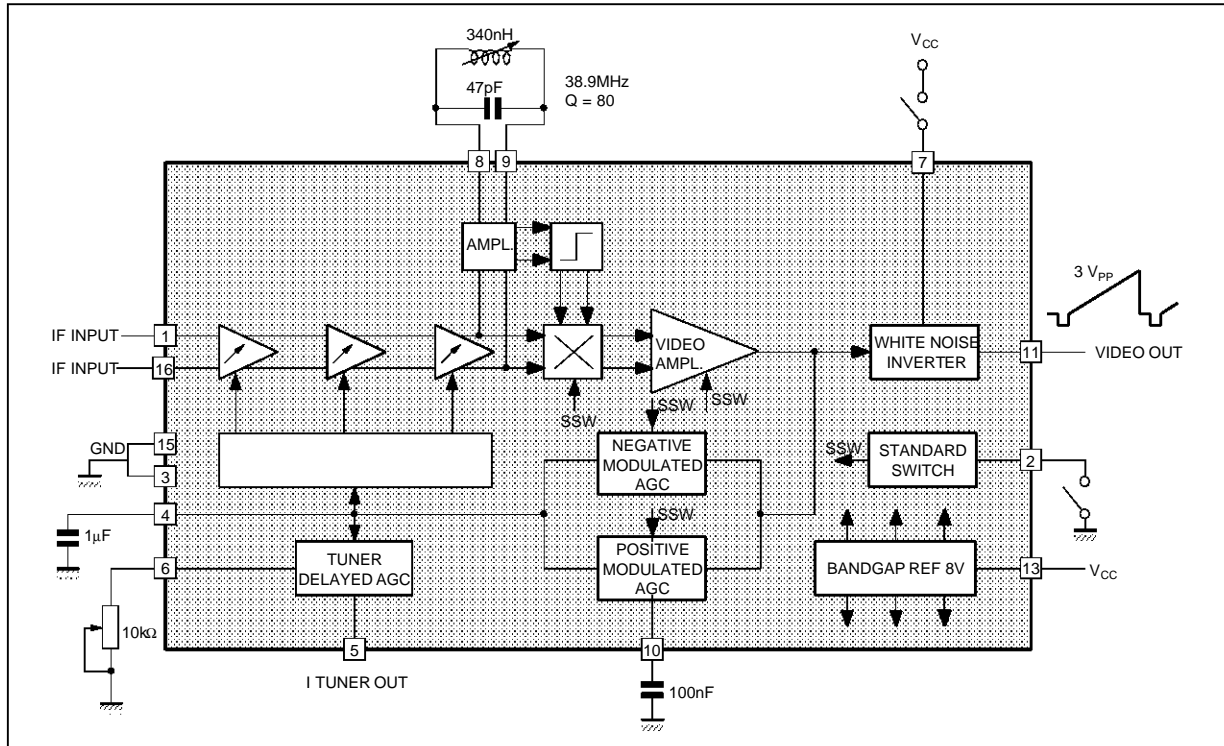

8123A-02.EPS

ABSOLUTE MAXIMUM RATINGS

Symbol	Parameter	Value	Unit
V_S	Supply Voltage	15	V
V_5	Tuner AGC Voltage	V_S	V
I_{11}	Video Out DC Out Current	10	mA
I_2	Pin 2 Input Current	1	mA
P	Power Dissipation at $T_{AMB} = 70^\circ\text{C}$	1	W
T_{stg}	Storage Temperature	- 40, + 150	$^\circ\text{C}$

8123A-01.TBL

THERMAL DATA

Symbol	Parameter	Value	Unit
$R_{th(j-a)}$	Junction-ambient Thermal Resistance	Max. 80	$^\circ\text{C}/\text{W}$

8123A-02.TBL

ELECTRICAL CHARACTERISTICS (unless otherwise specified)

$V_S = 12\text{V}$, $f_{VC} = 38.9\text{MHz}$, $V_{VC} = 10\text{mV}_{RMS}$

Mod. AM/DSB : $T_A = 25^\circ\text{C}$, Input Video Signal = Sawtooth

Standard B/G : $R = 10\%$, $D = 90\%$

Standard L : $M = 100\%$, $R < 6\%$

Parameter	Test Conditions	Min.	Typ.	Max.	Unit
Supply Voltage Range	V_{OUT} unchanged	10.8	12	13.2	V
Supply Current		40	57	74	mA
Input Sensitivity	$V_{OUT} = -3\text{dB}$		60		μV
AGC Range		60			dB
Top White Level B/G	See Fig.1		4.9		V
Top Sync. Level B/G	See Fig.1		1.9		V
DC Output Voltage for Zero Carrier B/G	See Fig.1		5.05		V

8123A-03.TBL

ELECTRICAL CHARACTERISTICS (unless otherwise specified) (continued)

$V_S = 12V$, $f_{VC} = 38.9MHz$, $V_{VC} = 10mV_{RM}$

Mod. AM/DSB : $T_A = 25^\circ C$, Input Video Signal = Sawtooth

Standard B/G : R = 10%, D = 90%

Standard L : M = 100%, R < 6%

Parameter	Test Conditions	Min.	Typ.	Max.	Unit
Top White Level L	See Fig.1		4.9		V
Top Sync. Level L	See Fig.1		1.9		V
DC Output Voltage for Zero Carrier L			1.9		V
Difference between V_{PP} B/G and V_{PP} L				10	%
Threshold of Negative Noise Clamp	Under the top sync. level - See Fig.1		100		mV
White Spot Inverter ON				1.2	V
			or unconnected		
White Spot Inverter OFF		2		V_S	V
White Inverter Threshold	Over the top white level - See Fig.1		900		mV
White Inverter Insertion Level	See Fig.1		3.5		V
Top White Level Relation versus Supply Voltage	V_S range		1		%
Top Black Level Relation versus Supply Voltage	V_S range		0.5		%
Video Output Peak to Peak Variation versus Supply Voltage	V_S range			1	%
Bandwidth (- 3dB)			10		MHz
Flatness of Video Response in the Whole AGC Range				2	dB
DC Output Current	Pin 11 held at 10V		2		mA
Residual Carrier at Video Output in the Whole AGC Range	38.9MHz 77.8MHz		10 20		mV mV
Differential Gain	B/G and L		3		%
Differential Phase	B/G and L		3		deg
Differential Gain Variation versus Detuning of $\pm 400kHz$ of LC at Pin 8 and 9				1	%
Differential Phase Variation versus Detuning of $\pm 400kHz$ of LC at Pin 8 and 9				2	deg
Intermodulation Products related to the Demodulated Color Carrier (1.07MHz)	Video carrier = 0dB Color carrier = -6dB Sound carrier = -20dB		50		dB
Compression of the sync. pulse in the Whole AGC Range			3		%
Switch Voltage B/G		2		V_S	V
Switch Voltage L		0		1.2	V
I_{TYP} of Charge AGC Standard B/G	See Fig. 2		1.7		mA
I_{TYP} of Discharge AGC Standard B/G	See Fig. 2		19		μA
AGC Reacting Time Standard L				10	μs
I_{TYP} of Charge AGC Standard L	See Fig. 3		5		mA
I_{TYP} of Discharge AGC Standard L	See Fig. 3		260		μA
I_{TYP} of Discharge of the Capacitor at Pin 4 during Stationary State			100		nA
AGC Tuner Current at 10dB over the AGC Start Point	See Fig. 4	3	4	5	mA
$\frac{\Delta I_{TUNER}}{\Delta V_{IF}}$ Slope	10% to 90% See Fig. 4		250		$\frac{\mu A}{dB}$
$\frac{\Delta I}{ \Delta T }$	$V_{IF} = \text{const.}$, $T_A = 100^\circ C$ $I_{TUNER} = I_{TUNER \text{ Max.}} / 2$		0.5		%
Input Resistance Symmetrical between Pins 1 and 16			1.6		k Ω
Input Capacitance Symmetrical between Pins 1 and 16			2		pF

8123A-04-TBL

TDA8123A

TEST CIRCUIT

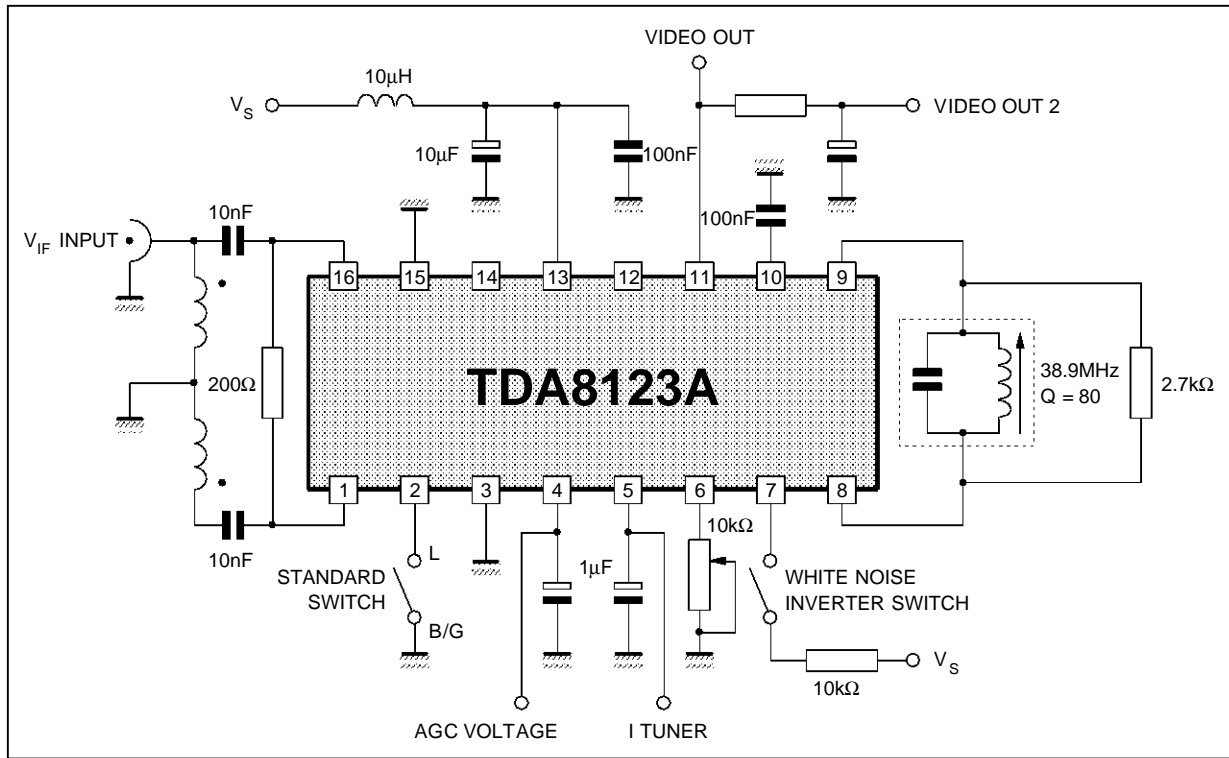

8123A-03.EPS

MEASUREMENTS CONFIGURATION

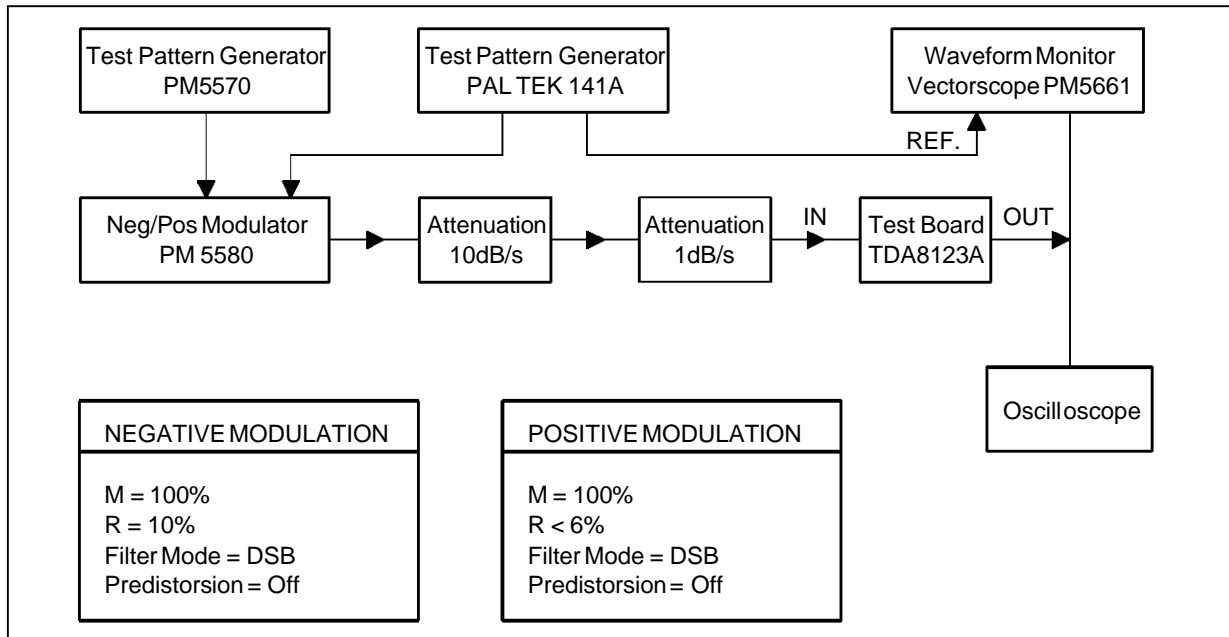

8123A-04.EPS

Figure 1 : Output Video Signal Levels

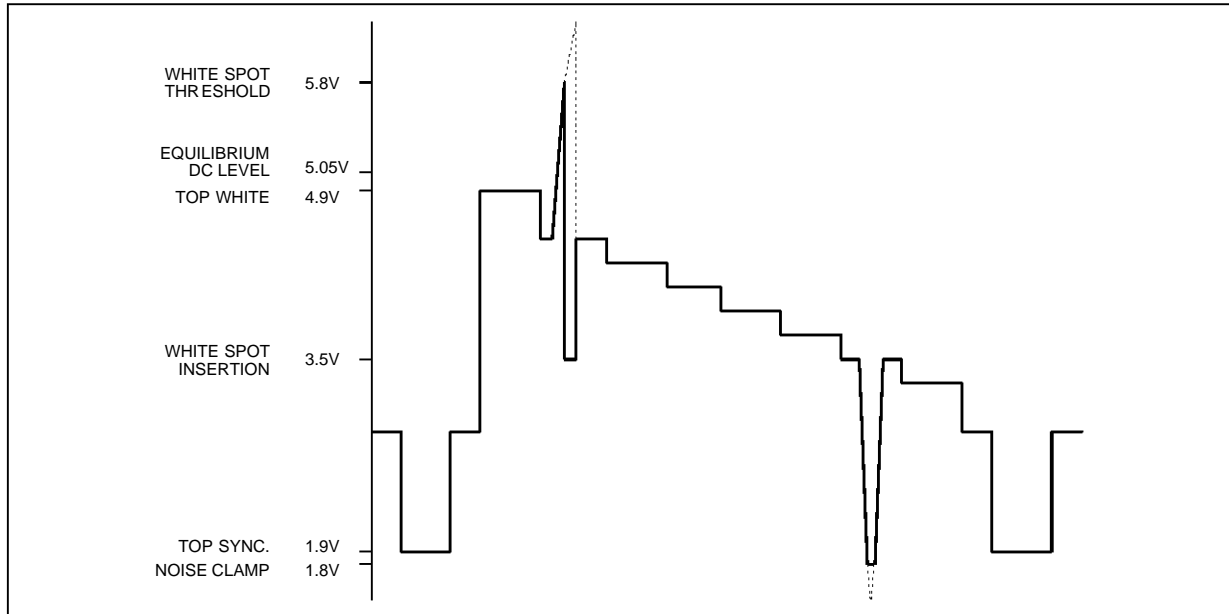

8123A-05.EPS

Figure 2 : AGC Current (standard B/G)

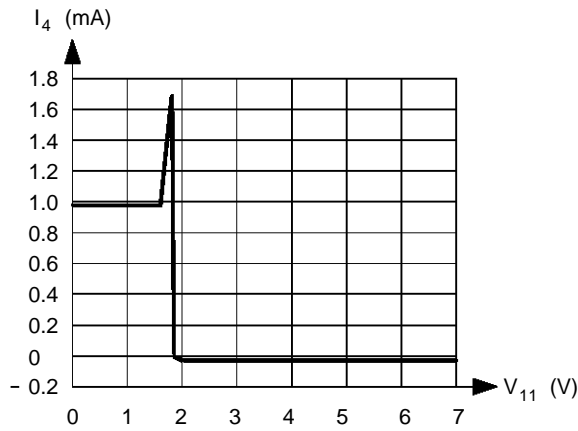

8123A-06.EPS

Figure 3 : AGC Current (standard L)

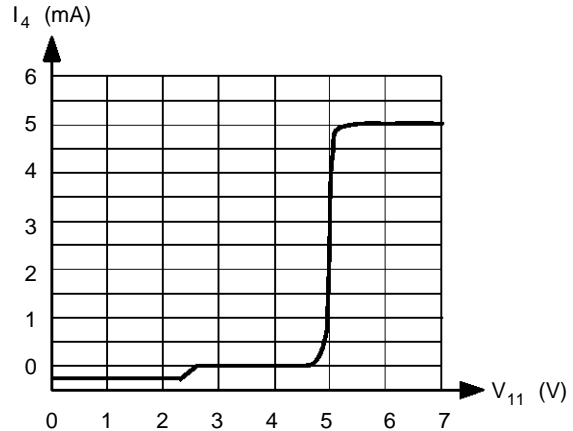

8123A-07.EPS

Figure 4 : Tuner AGC Output Current

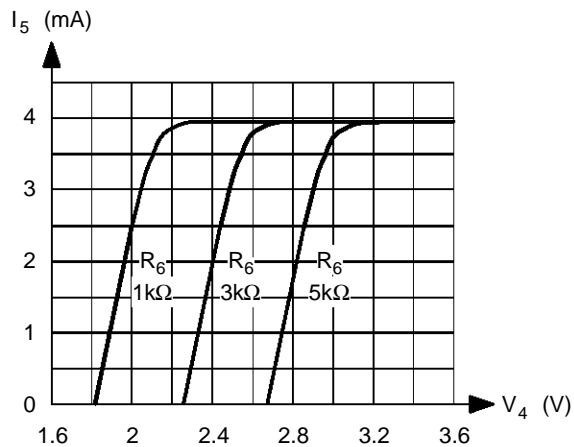

8123A-08.EPS

Figure 5 : Starting Point of Tuner Regulation

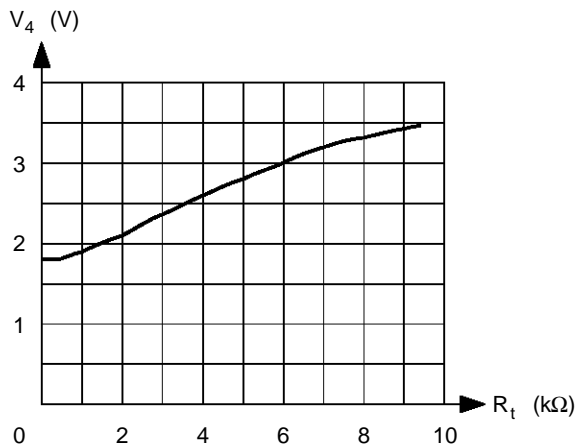

8123A-09.EPS

TDA8123A

PACKAGE MECHANICAL DATA

16 PINS - PLASTIC DIP

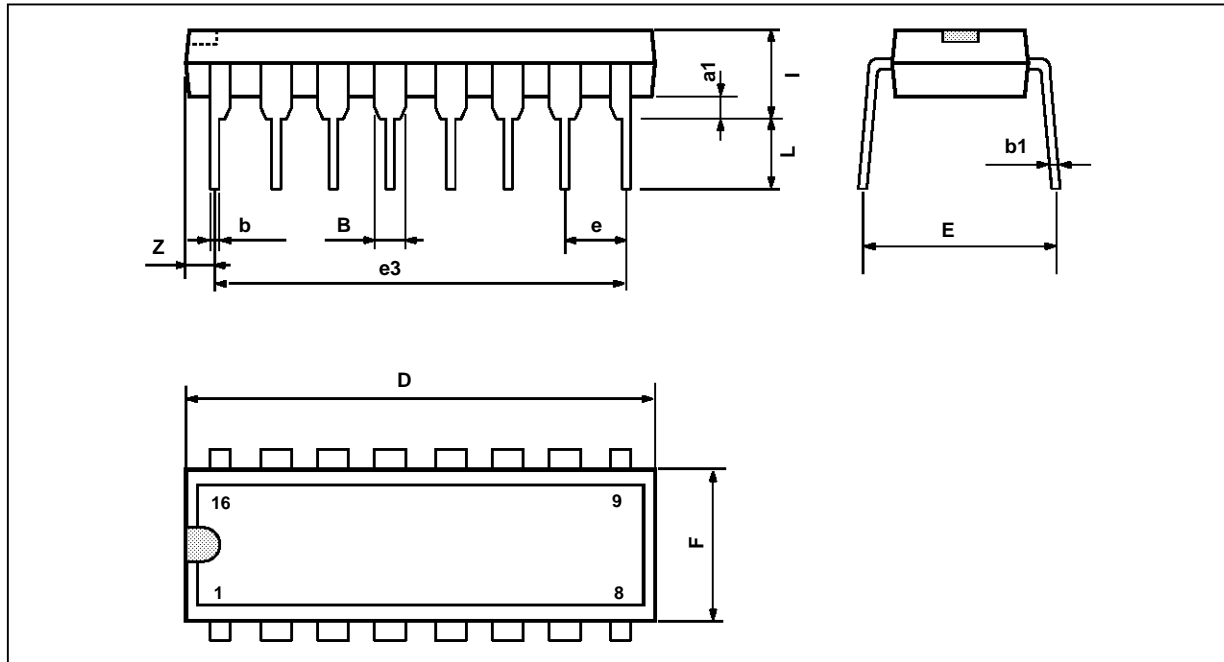

PM-DIP16.EPS

Dimensions	Millimeters			Inches		
	Min.	Typ.	Max.	Min.	Typ.	Max.
a1	0.51			0.020		
B	0.77		1.65	0.030		0.065
b		0.5			0.020	
b1		0.25			0.010	
D			20			0.787
E		8.5			0.335	
e		2.54			0.100	
e3		17.78			0.700	
F			7.1			0.280
i			5.1			0.201
L		3.3			0.130	
Z			1.27			0.050

DIP16.TBL

Information furnished is believed to be accurate and reliable. However, SGS-THOMSON Microelectronics assumes no responsibility for the consequences of use of such information nor for any infringement of patents or other rights of third parties which may result from its use. No licence is granted by implication or otherwise under any patent or patent rights of SGS-THOMSON Microelectronics. Specifications mentioned in this publication are subject to change without notice. This publication supersedes and replaces all information previously supplied. SGS-THOMSON Microelectronics products are not authorized for use as critical components in life support devices or systems without express written approval of SGS-THOMSON Microelectronics.

© 1994 SGS-THOMSON Microelectronics - All Rights Reserved

Purchase of I²C Components of SGS-THOMSON Microelectronics, conveys a license under the Philips I²C Patent. Rights to use these components in a I²C system, is granted provided that the system conforms to the I²C Standard Specifications as defined by Philips.

SGS-THOMSON Microelectronics GROUP OF COMPANIES

Australia - Brazil - China - France - Germany - Hong Kong - Italy - Japan - Korea - Malaysia - Malta - Morocco
The Netherlands - Singapore - Spain - Sweden - Switzerland - Taiwan - Thailand - United Kingdom - U.S.A.