

**TV VERTICAL DEFLECTION SYSTEM
FOR TV AND MONITORS**

- SYNCHRONIZATION CIRCUIT
- OSCILLATOR AND RAMP GENERATOR
- HIGH POWER GAIN AMPLIFIER
- FLYBACK GENERATOR
- VOLTAGE REGULATOR

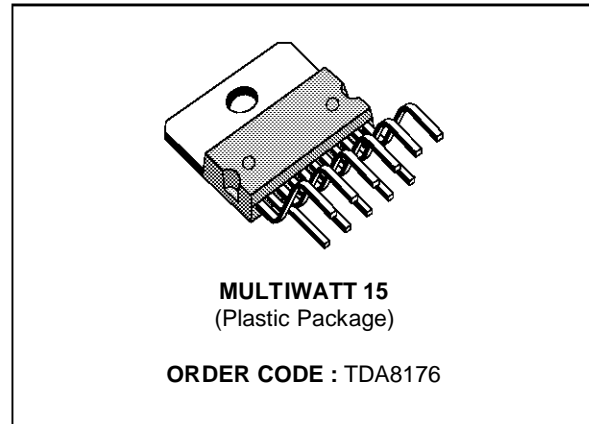

DESCRIPTION

The TDA8176 is a monolithic integrated circuit in Multiwatt 15 package. It is intended for use in color TV sets and monitors.

PIN CONNECTIONS

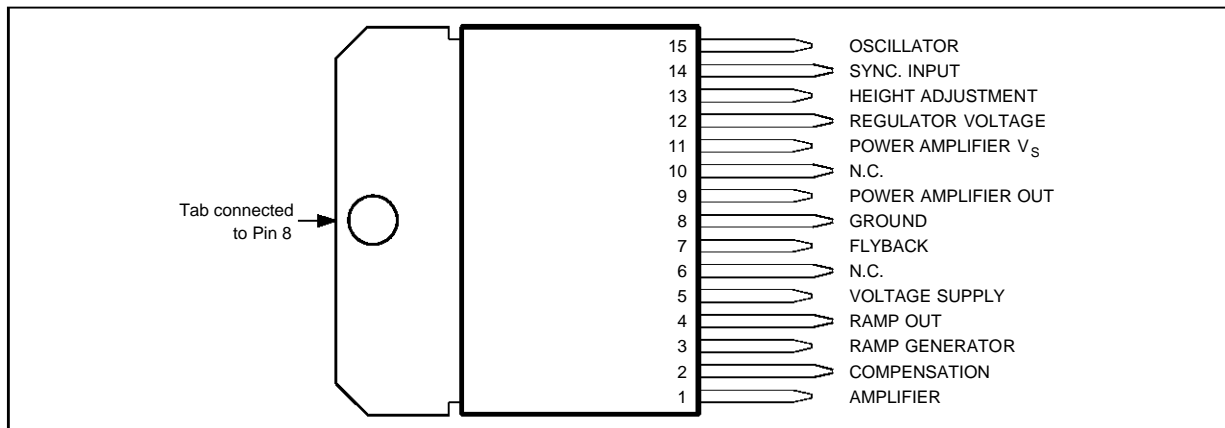

8176-01.EPS

BLOCK DIAGRAM

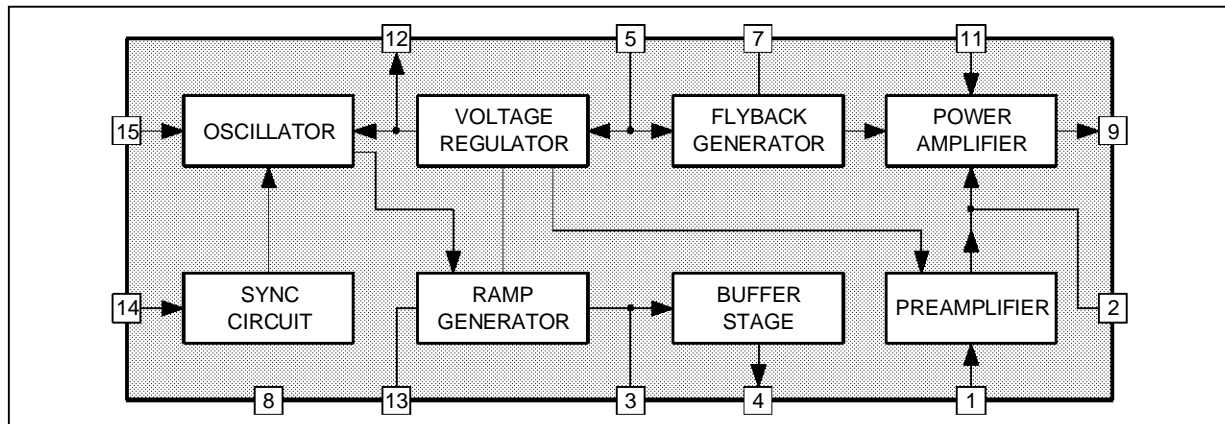

8176-02.EPS

ABSOLUTE MAXIMUM RATINGS

Symbol	Parameter	Value	Unit
V ₅	Supply Voltage at Pin 2	35	V
V ₄ , V ₅	Flyback Peak Voltage	60	V
V ₁₀	Power Amplifier Input Voltage	+ 10 - 0.5	V V
I _o	Output Peak Current (non repetitive) at t = 2 ms	2	A
I _o	Output Peak Current at f = 50 Hz t ≤ 10 μs	2.5	A
I _o	Output Peak Current at f = 50 Hz t > 10 μs	1.5	A
I ₃	Pin 3 DC Current at V ₄ < V ₂	100	mA
I ₃	Pin 3 Peak to Peak Flyback Current for f = 50 Hz, t _{fly} ≤ 1.5 ms	1.8	A
I ₈	Pin 8 Current	± 20	mA
P _{tot}	Power Dissipation at T _{tab} = 90 °C at T _{amb} = 80 °C	20 1.4	W W
T _{stg} , T _j	Storage and Junction Temperature	- 40, + 150	°C

8176-02.TBL

THERMAL DATA

Symbol	Parameter	Value	Unit
R _{th(j-c)}	Thermal Resistance Junction-case	Max. 3	°C/W
R _{th(j-a)}	Thermal Resistance Junction-ambient	Max. 50	°C/W

8176-02.TBL

AC ELECTRICAL CHARACTERISTICS

(refer to the test circuit, V_S = 25V ; f = 50Hz ; T_{amb} = 25°C, unless otherwise specified)

Symbol	Parameter	Test Conditions	Min.	Typ.	Max.	Unit
I _s	Supply Current	I _y = 1 App		140		mA
I ₁₄	Sync. Input Current (positive or negative)		500			μA
V ₉	Flyback Voltage	I _y = 1 App		51		V
V ₁₅	Peak to peak Oscillator Sawtooth Voltage			2.4		V
t _{fly}	Flyback Time	I _y = 1 App		0.7		ms
f _o	Free Running Frequency	(P ₁ + R ₁) = 300kΩ C ₂ = 100 nF		44		Hz
		(P ₁ + R ₁) = 260kΩ C ₂ = 100 nF		52		Hz
Δf	Synchronization Range	I ₈ = 0.5 mA	14			Hz
$\frac{\Delta f}{\Delta V_S}$	Frequency Drift with Supply Voltage	V _s = 10 to 35 V		0.005		Hz/V
$\frac{\Delta f}{\Delta T_{tab}}$	Frequency Drift with Tab Temperature	T _{tab} = 40 to 120 °C		0.01		Hz/°C

8176-03.TBL

DC ELECTRICAL CHARACTERISTICS ($V_S = 35V$, $T_{amb} = 25^\circ C$ unless otherwise specified)

Symbol	Parameter	Test Conditions	Min.	Typ.	Max.	Unit
I_5	Pin 5 Quiescent Current	$I_7 = 0$		7	14	mA
I_{11}	Pin 11 Quiescent Current	$I_9 = 0$		8	17	mA
$-I_{15}$	Oscillator Bias Current	$V_{15} = 1 V$		0.1	1	μA
$-I_1$	Amplifier Input Bias Current	$V_1 = 1 V$		0.1	10	μA
$-I_3$	Ramp Generator Bias Current	$V_3 = 0$		0.02	0.3	μA
$-I_3$	Ramp Generator Current	$I_{13} = 20 \mu A$, $V_3 = 0$	18.5	20	21.5	μA
$\frac{\Delta I_3}{I_3}$	Ramp Generator Non-linearity	$\Delta V_{12} = 0$ to $12 V$ $I_{13} = 20 \mu A$		0.2	1	%
V_S	Supply Voltage Range		10		35	V
V_4	Pin 4 Saturation Voltage to Ground	$I_4 = 1 mA$		1	1.4	V
V_7	Pin 7 Saturation Voltage to Ground	$I_7 = 10 mA$		300	450	mV
V_9	Quiescent Output Voltage	$V_S = 10 V$ $R_1 = 10 k\Omega$ $R_2 = 10 k\Omega$	4.1	4.4	4.75	V
		$V_S = 35 V$ $R_1 = 30 k\Omega$ $R_2 = 10 k\Omega$	8.3	8.8	9.45	V
V_{9L}	Output Saturation Voltage to Ground	$-I_9 = 0.1 A$		0.9	1.2	V
		$-I_9 = 0.8 A$		1.9	2.3	V
V_{9H}	Output Saturation Voltage to Supply	$I_9 = 0.1 A$		1.4	2.1	V
		$I_9 = 0.8 A$		2.8	3.2	V
V_{12}	Regulated Voltage at Pin 12		6.1	6.5	6.9	V
V_{13}	Regulated Voltage at Pin 13	$I_{13} = 10 \mu A$	6.2	6.6	7	V
$\frac{\Delta V_{12}}{\Delta V_S}, \frac{\Delta V_{13}}{\Delta V_S}$	Regulated Voltage Drift with Supply Voltage	$\Delta V_S = 10$ to $35 V$		1		mV/V
V_1	Amplifier Input Reference Voltage		2.07	2.2	2.3	V
R_{14}	Pin 8 Input Resistance	$V_{14} \leq 0.4 V$	1			M Ω

8176-04.TBL

TYPICAL PERFORMANCE OF THE CIRCUIT OF FIG.1

Symbol	Parameter	Value	Unit
V_S	Operating Supply Voltage	25	V
I_S	Supply Current	175	mA
t_{fly}	Flyback Time	1	ms
P_{tot}	Power Dissipation	3.25	W
i_y	Maximum Scanning Current (peak-to-peak)	1.4	A

8176-05.TBL

AC TEST CIRCUITS

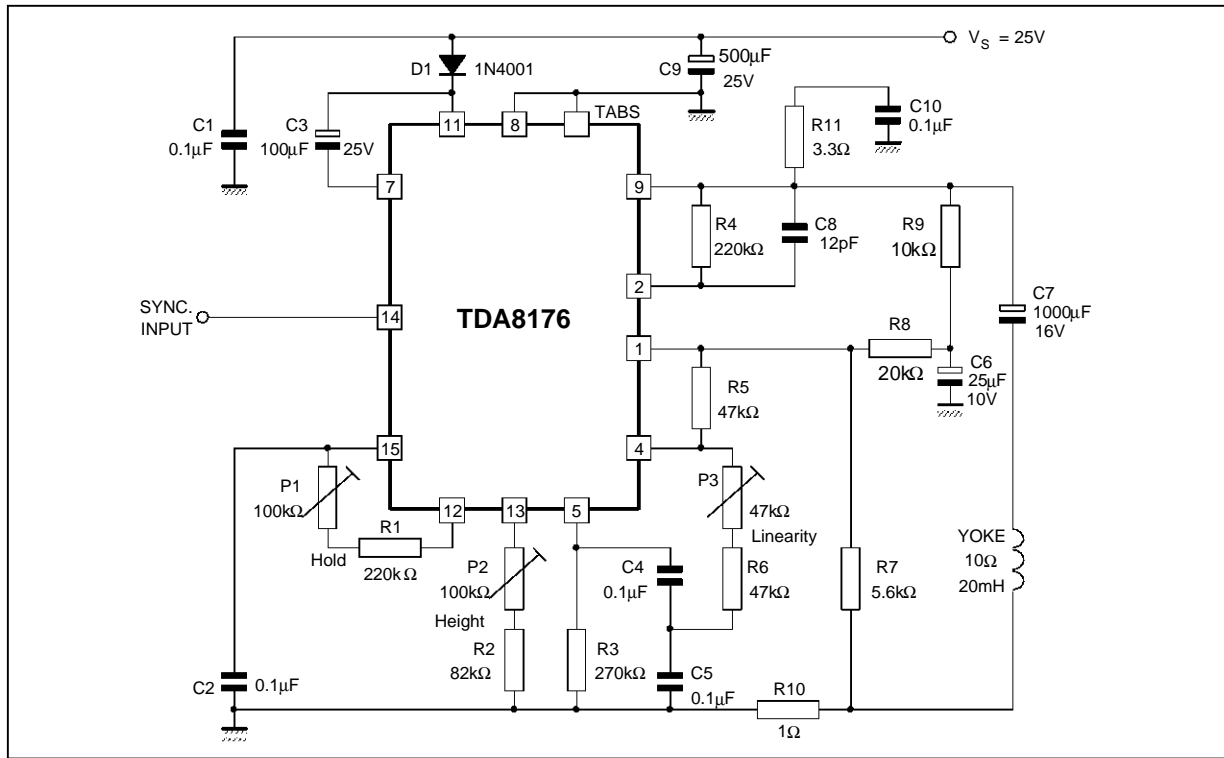

8176-03.EPS

Figure 1 : Typical Application Circuit for large Screen 110° PIL TVC Set ($R_y = 10 \Omega$; $L_y = 25 \text{ mH}$; $I_y = 1.25 \text{ App}$).

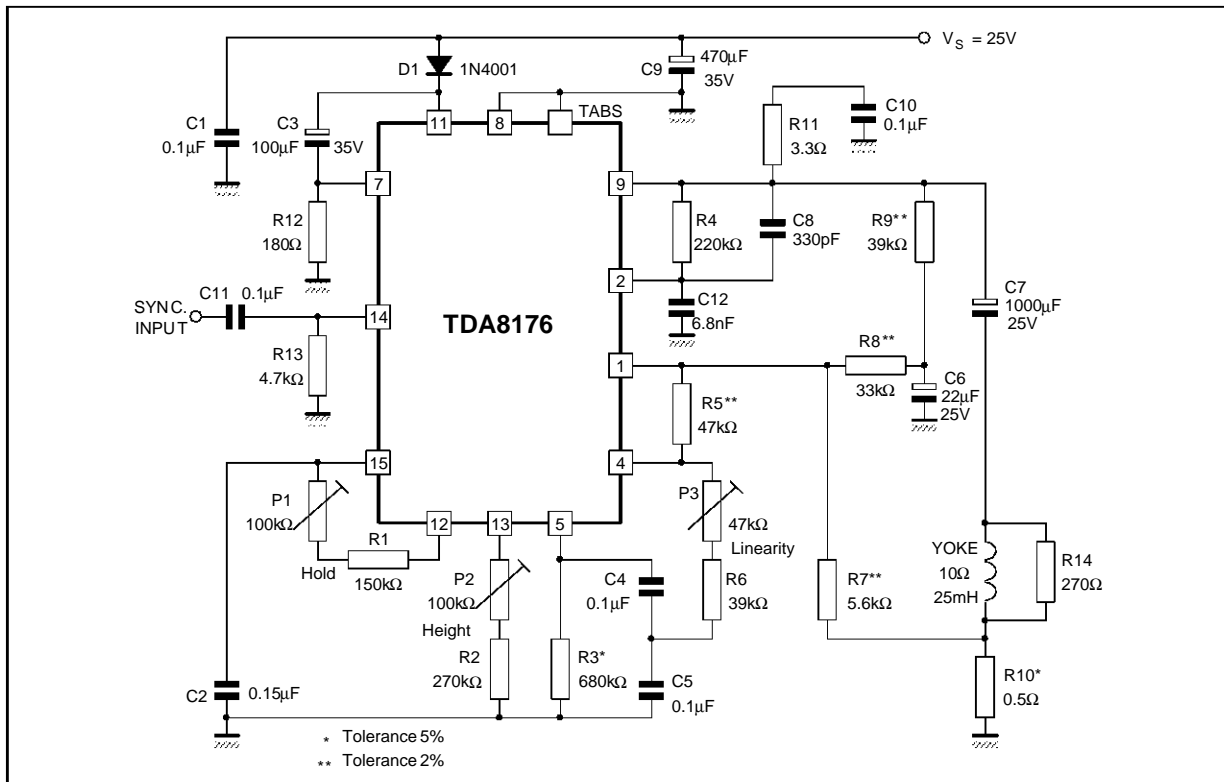

8176-04.EPS

PACKAGE MECHANICAL DATA : 15 PINS - PLASTIC MULTIWATT

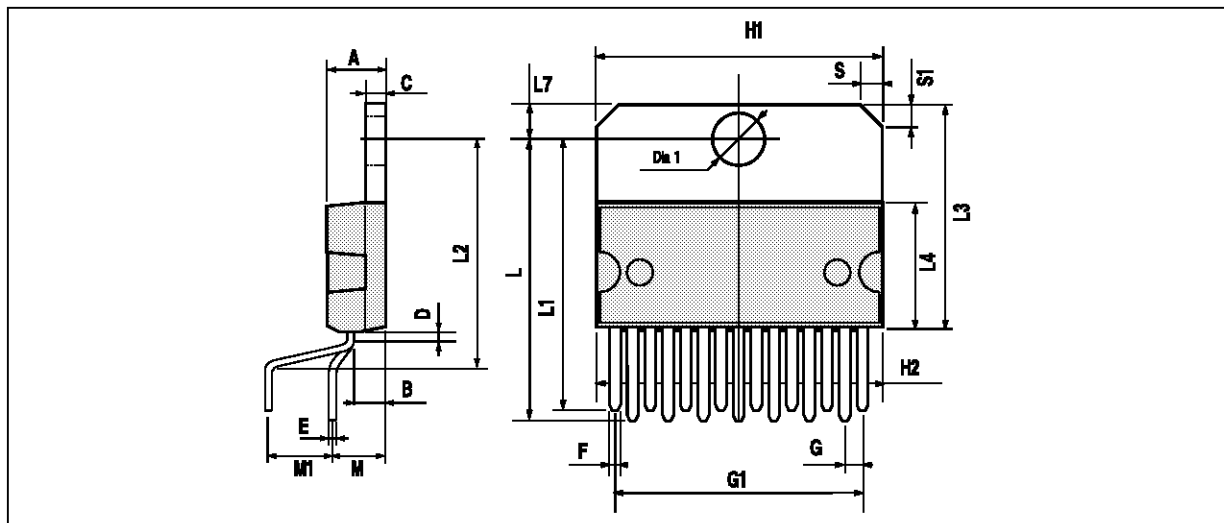

PMMUL15V.EPS

Dimensions	Millimeters			Inches		
	Min.	Typ.	Max.	Min.	Typ.	Max.
A			5			0.197
B			2.65			0.104
C			1.6			0.063
D		1			0.039	
E	0.49		0.55	0.019		0.022
F	0.66		0.75	0.026		0.030
G	1.14	1.27	1.4	0.045	0.050	0.055
G1	17.57	17.78	17.91	0.692	0.700	0.705
H1	19.6			0.772		
H2			20.2			0.795
L	22.1		22.6	0.870		0.890
L1	22		22.5	0.866		0.886
L2	17.65		18.1	0.695		0.713
L3	17.25	17.5	17.75	0.679	0.689	0.699
L4	10.3	10.7	10.9	0.406	0.421	0.429
L7	2.65		2.9	0.104		0.114
M	4.2	4.3	4.6	0.165	0.169	0.181
M1	4.5	5.08	5.3	0.177	0.200	0.209
S	1.9		2.6	0.075		0.102
S1	1.9		2.6	0.075		0.102
Dia. 1	3.65		3.85	0.144		0.152

MUL15V.TBL

Information furnished is believed to be accurate and reliable. However, SGS-THOMSON Microelectronics assumes no responsibility for the consequences of use of such information nor for any infringement of patents or other rights of third parties which may result from its use. No licence is granted by implication or otherwise under any patent or patent rights of SGS-THOMSON Microelectronics. Specifications mentioned in this publication are subject to change without notice. This publication supersedes and replaces all information previously supplied. SGS-THOMSON Microelectronics products are not authorized for use as critical components in life support devices or systems without express written approval of SGS-THOMSON Microelectronics.

© 1994 SGS-THOMSON Microelectronics - All Rights Reserved

Purchase of I²C Components of SGS-THOMSON Microelectronics, conveys a license under the Philips I²C Patent. Rights to use these components in a I²C system, is granted provided that the system conforms to the I²C Standard Specifications as defined by Philips.

SGS-THOMSON Microelectronics GROUP OF COMPANIES

Australia - Brazil - China - France - Germany - Hong Kong - Italy - Japan - Korea - Malaysia - Malta - Morocco
The Netherlands - Singapore - Spain - Sweden - Switzerland - Taiwan - Thailand - United Kingdom - U.S.A.