

TDC1016

Video Speed D/A Converter

10-Bit, 20 Msp/s

Features

- 20 Msp/s conversion rate
- 8, 9, or 10-bit linearity
- Voltage output, no amplifier required
- Single supply operation (-5.2V, ECL compatible)
- Dual supply operation ($\pm 5.0V$, TTL compatible)
- Internal 10-bit latched data register
- Low glitch energy
- Disabling controls, forcing full-scale, zero, and inverting input data
- Binary or two's complement input data formats
- Differential gain = 1.5%, differential phase = 1.0°

Applications

- Construction of video signals from digital data 3x or 4x NTSC or PAL color subcarrier frequency
- CRT graphics displays, RGB, Raster, Vector
- Waveform synthesis

Description

The TDC1016 is a bipolar monolithic digital-to-analog converter which can convert digital data into an analog voltage at rates up to 20 Msp/s (Megsamples Per Second). The device includes an input data register and operates without an external deglitcher or amplifier.

Operating the TDC1016 from a single -5.2V power supply will bias the digital inputs for ECL levels, while operating from a dual $\pm 5V$ power supply will bias the digital inputs for TTL levels.

All versions of the TDC1016 are 10-bit digital-to-analog converters, but are available with linearity specifications of either 8, 9, or 10 bits. The TDC1016 is patented under U.S. patent number 3283120 with other patents pending.

Block Diagram

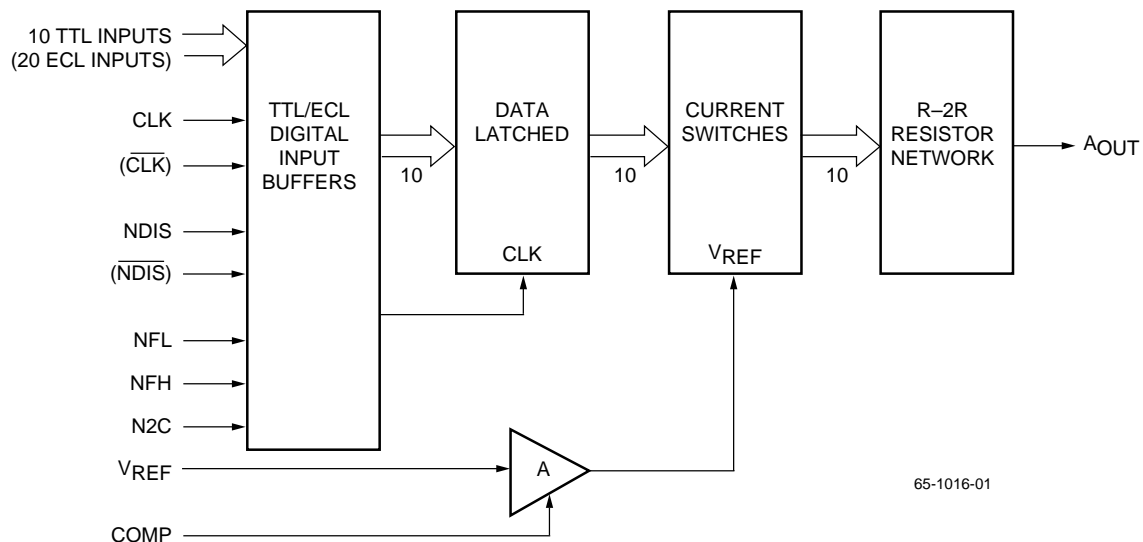

Functional Description

General Information

TTL/ECL buffers are used for all digital inputs to the TDC1016. Logic family compatibility depends upon the connection of power supplies. When single power supply (-5.2V) operation is employed, all data, clock, and disable inputs are compatible with differential ECL logic levels. All digital inputs become compatible with TTL levels when dual power supply ($\pm 5.0V$) operation is used.

The internal 10-bit register latches data on the rising edge of the clock (CLK) pulse. Currents from the current sources are switched accordingly and combined in the resistor network to give an analog output voltage. The magnitude of the output voltage is directly proportional to the magnitude of the digital input word.

The NFL and NFH inputs can be used to simplify system calibration by forcing the analog output voltage to either its zero-scale or full-scale value. The TDC1016 can be operated in binary, inverse binary, two's complement or inverse two's complement input data formats.

Power

The TDC1016 can be operated from a single -5.2V power supply or from a dual $\pm 5.0V$ power supply. For single power supply operation, VCC is connected to DGND and all inputs to the device become ECL compatible. When VCC is tied to +5.0V, the inputs are TTL compatible.

The return path for the output from the 10 current sources is AGND. The current return path for the digital section is DGND. DGND and AGND should be returned to system power supply ground by way of separate conductive paths to prevent digital ground noise from disturbing the analog circuitry of the TDC1016. All AGND pins must be connected to system analog ground.

Reference

The reference input is normally set to -1.0V with respect to AGND. Adjusting this voltage is equivalent to adjusting system gain. The temperature stability of the TDC1016 analog output (AOUT) depends primarily upon the temperature stability of the applied reference voltage.

The internal operational amplifier of the TDC1016 is frequency stabilized by an external 1 μF tantalum capacitor connected between the COMP pin and VEE. A minimum of 1 μF is adequate for most applications, but 10 microfarads or more is recommended for optimum performance. The negative side of this capacitor should be connected to VEE.

Controls

The NDIS inputs are used to disable the TDC1016 by forcing its output to the zero-scale value (current sources off). The NDIS inputs are asynchronous, active without regard to the CLK inputs. The other digital control inputs are synchronous, latched on the rising edge of the CLK pulse.

The rising edge of the CLK pulse transfers data from the input lines to the internal 10-bit register. In TTL mode, the inverted inputs for CLK, DATA, and NDIS are inactive and should be left open.

The Input Coding Table illustrates the function of the digital control inputs. A two's complement mode is created by activating N2C with a Logic 0. When NFH and NFL are both activated with a Logic 0 the input data to the 10-bit register is inverted.

Data Inputs

Data inputs are ECL compatible when single power supply operation is employed. The J5 and C2 packages allow for differential ECL inputs while the J7 and B7 packages have only single-ended inputs. When differential ECL data is used, any data input can be inverted simply by reversing the connections to the true and inverted data input pins. All inverted input pins should be left open if single-ended ECL or TTL modes are used. All data inputs have an internal 40 K Ω pullup resistor to VCC.

Analog Output

The analog output voltage is negative with respect to AGND and varies proportionally with the magnitude of the input data word. The output resistance at this point is 80 Ω , nominally.

No Connects

There are several pins labeled no connect (NC) on the TDC1016 J5 and C2 packages, which have no connections to the chip. These pins should be left open.

Pin Assignments

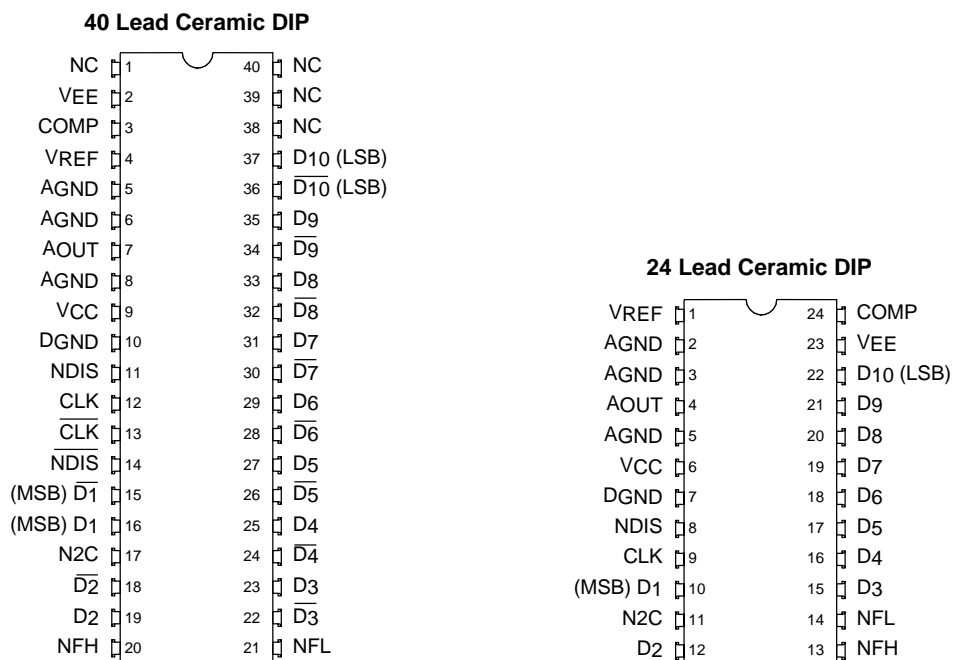

65-1016-02

Pin Descriptions

Pin Name	Pin Number		Value	Pin Function Description
	40-Lead	24-Lead		
Power				
VCC	9	6	+5.0V	Positive Supply Voltage.
VEE	2	23	-5.0V	Negative Supply Voltage.
AGND	5, 6, 8	2, 3, 5	0.0V	Analog Ground.
DGND	10	7	0.0V	Digital Ground.
Reference				
VREF	4	1	-1.0V	Reference Voltage In.
COMP	3	24	1 μ F	Compensation.
Controls				
NDIS	11	8	TTL/ECL	Not Disable.
NDIS	14	—	ECL	Not Disable (Inv).
CLK	12	9	TTL/ECL	Clock.
\overline{CLK}	13	—	ECL	Clock (Inv).
N2C	17	11	TTL/ECL	Not Two's Complement.
NFH	20	13	TTL/ECL	Not Force HIGH.
NFL	21	14	TTL/ECL	Not Force LOW.
Data Inputs				
D1–D10	16, 19, 23, 25, 27, 29, 31, 33, 35, 37	10, 12, 15–20, 27, 22	TTL/ECL	Data Bits 1–10. D1 is the MSB, D10 is the LSB.

Pin Descriptions (continued)

Pin Name	Pin Number		Value	Pin Function Description
	40-Lead	24-Lead		
$\overline{D}1\text{--}\overline{D}10$	15, 18, 22, 24, 26, 28, 30, 32, 34, 36	—	ECL	Data Bits 1–10 (Inv). $\overline{D}1$ is the MSB, $\overline{D}10$ is the LSB.
Analog Output				
AOUT	7	4	0V–1V	Analog Output Voltage
No Connection				
NC	1, 38–40	—	Open	No Connection

Absolute Maximum Ratings (beyond which the device will be damaged)¹

Parameter	Min.	Max.	Unit
Supply Voltages			
VCC (measured to DGND)	-0.5	+7.0	V
VEE (measured to AGND)	-7.0	+0.5	V
AGND (measured to DGND)	-0.5	+0.5	V
Input Voltages			
Digital (measured to DGND)	-7.0	+7.0	V
Reference (measured to AGND)	-1.5	+0.5	V
Output			
Applied Voltage (measured to AGND) ²	-2.0	+2.0	V
Short-Circuit Duration	Indefinite		
Temperature			
Operating, Ambient		+125	°C
Operating, Junction		+175	°C
Lead, Soldering (10 seconds)		+300	°C
Storage	-65	+150	°C

Notes:

1. Absolute maximum ratings are limiting values applied individually while all other parameters are within specified operating conditions. Functional operation under any of these conditions is NOT implied.
2. Applied voltage must be current limited to specified range.

Operating Conditions

Symbol	Parameter	Temperature Range							Unit
		Standard			Extended				
		Min.	Nom.	Max.	Min.	Nom.	Max.		
VCC	Positive Supply Voltage	TTL Mode	4.75	5.0	5.25	4.50	5.0	5.50	V
		ECL Mode	-0.25	0.0	0.25	-0.25	0.0	0.25	V
VEE	Negative Supply Voltage		-4.5	-5.0	-5.5	-4.5	-5.0	-5.5	V
VAGND	Analog Ground Voltage (Measured to DGND)		-0.1	0.0	0.1	-0.1	0.0	0.1	V
tPWL	CLK Pulse Width, LOW		15			20			ns
tPWH	CLK Pulse Width, HIGH		15			20			ns
tS	Input Register Set-up Time	TTL Mode	20			22			ns
		ECL Mode	25			27			ns
tH	Input Register Hold Time		2			2			ns
VIL	Logic 0	TTL Mode	DGND		0.8	DGND		0.8	V
		ECL Mode			-1.67			-1.67	V
VIH	Logic 1	TTL Mode	2.0		VCC	2.0 ¹		VCC	V
		ECL Mode	-1.0			-1.0			V
VREF	Reference Voltage		-0.8	-1.0	-1.2	-0.8	-1.0	1.2	V
CCOMP	Compensation Capacitor		1.0			1.0			μF
TA	Ambient Temperature		0		70				°C
TC	Case Temperature					-55		125	°C

Note:

1. $V_{IH}/NDIS = 2.2$ Min.

DC Electrical Characteristics

Symbol	Parameter	Test Conditions	Temperature Range				Unit
			Standard		Extended		
			Min.	Max.	Min.	Max.	
ICC	Power Supply Current	TTL Mode, VCC = Max, VEE = Max		20		20	mA
IEE	Power Supply Current	TTL Mode, VCC = Max, VEE = Max ¹		-130		-150	mA
IREF	Reference Input Current	VEE = Max, VREF = -10V		10		10	μA
IIL	Logic 0 Input Current	TTL Mode, VCC = Max, VEE = Max		-1.0		-1.0	mA
		ECL Mode, VCC = 0.0, VEE = Max		-300		-300	μA
IIH	Logic 1 Input Current	TTL Mode, VCC = Max, VEE = Max		75		75	μA
		ECL Mode, VCC = 0.0, VEE = Max		350		350	μA
COUT	Output Capacitance	AOUT to AGND (Figure 2)		10		10	pF
CIN	Digital Input Capacitance	Any Digital Input to DGND		35		35	pF
ROUT	Output Resistance	AOUT to AGND (Figure 2)	70	95	70	95	Ω

Note:

1. Return current from VEE flows through AGND.

AC Electrical Characteristics

Symbol	Parameter	Test Conditions	Temperature Range				Unit
			Standard		Extended		
			Min.	Max.	Min.	Max.	
Fc	Maximum Data Rate	TTL Mode Full-Scale Output Step	20		20		MSPS
		ECL Mode Full-Scale Output Step	17.8		17.8		MSPS
t _{DS}	Data Turn on Delay	RL = 75 Ohms		30		30	ns
t _{SET}	Settling Time	TDC1016-8 to 0.2%		30		30	ns
		TDC1016-9 to 0.1%		35		35	ns
		TDC1016-10 to .05%		40		40	ns
t _{RV}	Output 10% to 90% Risetime	V _{EE} = Nom., RL = 75Ω, Full-Scale Step		5.5		5.5	ns

Timing Diagram

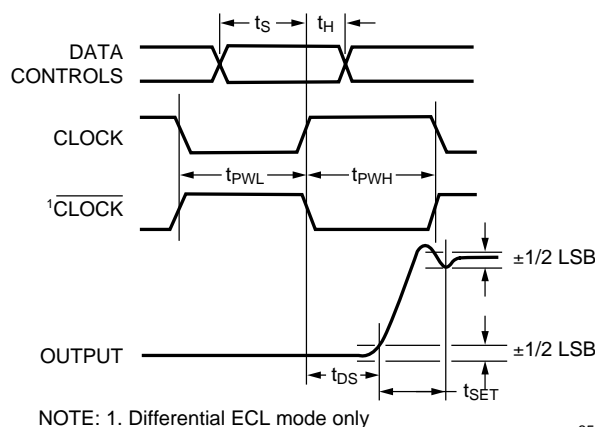

65-1016-06

Figure 1. Timing Diagram

System Performance Characteristics

Parameter		Test Conditions	Temperature Range				Unit
			Standard		Extended		
			Min.	Max.	Min.	Max.	
RES	Resolution	All TDC1016 Devices		10		10	Bits
ELI, ELD	Linearity Error Integral and Differential, Independent Based	TDC1016-8		0.2		0.2	% FS
		TDC1016-9		0.1		0.1	% FS
		TDC1016-10		0.075			% FS
VOFS	Full-Scale Output Voltage	V _{EE} = Nom, RL ≥ 10kΩ, V _{REF} = -1.000V	-0.95	-1.05	-0.95	-1.05	V
VOZS	Zero-Scale Output Voltage	V _{EE} = Nom, RL ≥ 10 kΩ, V _{REF} = -1.000V		±15		±15	mV
DP	Differential Phase	NTSC 4x Subcarrier ¹		1.0		1.0	Degrees
DG	Differential Gain	NTSC 4x subcarrier ¹		1.5		1.5	%
GE	Glitch Energy (Area)	RL = 50Ω, Midscale		125		125	pV-sec
GV	Glitch Voltage	RL = 50Ω, Midscale		35		35	mV

Note:

1. In excess of theoretical DP and DG due to quantizing error.

Equivalent Circuits

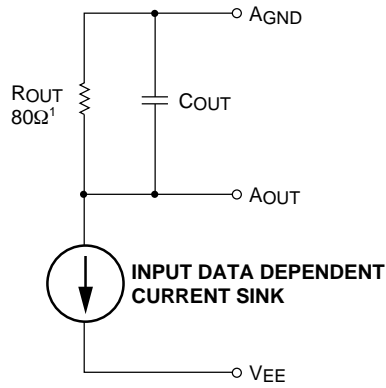

NOTE: 1. 75Ω requires outside trim 65-1016-03

Figure 2. Analog Output Equivalent Circuit, TTL and ECL Mode

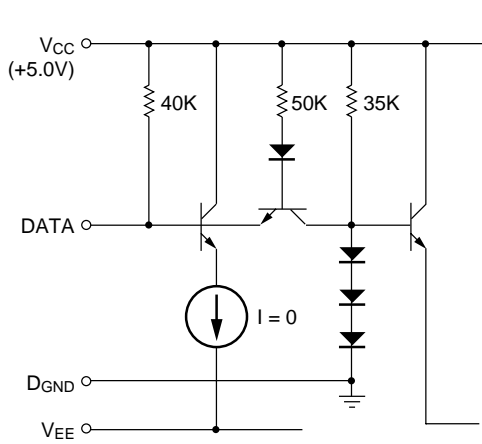
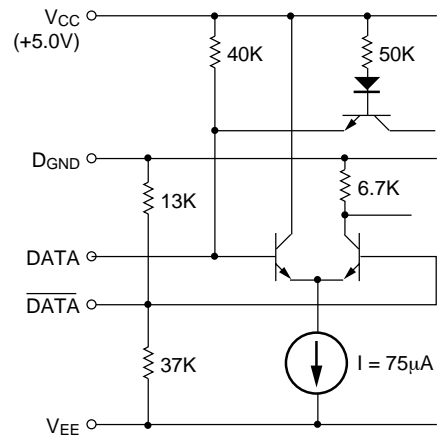

Figure 3. Digital Input Equivalent Circuit, TTL Mode



65-1016-04

Figure 4. Digital Input Equivalent Circuit, ECL Mode

Input Coding Table

NDIS	N2C	NFH	NFL	Data	Output	Description
0	x	x	x	xxxxxxxxxx	0.0	Output Disabled
1	1	1	1	1111111111	0.0	Binary (Default State for TTL Mode Control) Inputs Open
1	1	1	1	0000000000	-1.0	
1	1	0	0	1111111111	-1.0	Inverse Binary
1	1	0	0	0000000000	0.0	
1	0	1	1	0111111111	0.0	Two's Complement
1	0	1	1	1000000000	-1.0	
1	0	0	0	0111111111	-1.0	Inverse Two's Complement
1	0	0	0	1000000000	0.0	
1	x	0	1	xxxxxxxxxx	0.0	Force HIGH
1	x	1	0	xxxxxxxxxx	-1.0	Force LOW

Notes:

1. For TTL, $0.0 < V_{IL} < +0.8V$ is Logic 0.
2. For TTL, $+2.0 < V_{IH} < +5.0V$ is Logic 1.
3. For ECL, $-1.85 < V_{IL} < -1.67V$ is Logic 0.
4. For ECL, $-1.0 < V_{IH} < -0.8V$ is Logic 1.
5. x = don't care.

Applications Discussion

Calibration

The TDC1016 is calibrated by adjusting the voltage reference to give the desired full-scale output voltage. The current switches can be turned on either by loading the data register with full-scale data or by bringing the NFH input to a logic zero. Note that all 10 current switches are activated by the NFH input and the resulting full-scale output voltage will be greater than if the system used only eight or nine bits for full-scale data.

Typical Application

The Typical Interface Circuit (Figure 5) shows the TDC1016 in a typical application, reconstructing video signals from digital data. Television timing signals, SYNC and BLANKING, are added by injecting current from the Wilson current source into a resistor divider circuit at the output of the TDC1016.

The TDC1016 output and currents from the SYNC and BLANKING inputs are summed and amplified by the HA2539 wide-band operational amplifier. Note the careful power supply decoupling at the power input pins of the amplifier. The output of the circuit is a composite video signal with SYNC and BLANKING levels coming from external sources. This technique allows the TDC1016 to use its entire dynamic range for the video information while pulses are added by other means.

The reference for the TDC1016 is generated by dividing the output voltage from a two-terminal band-gap voltage reference. System gain is calibrated by adjusting variable resistor R1. Analog and digital grounds should be routed back to system power supply ground by separate paths.

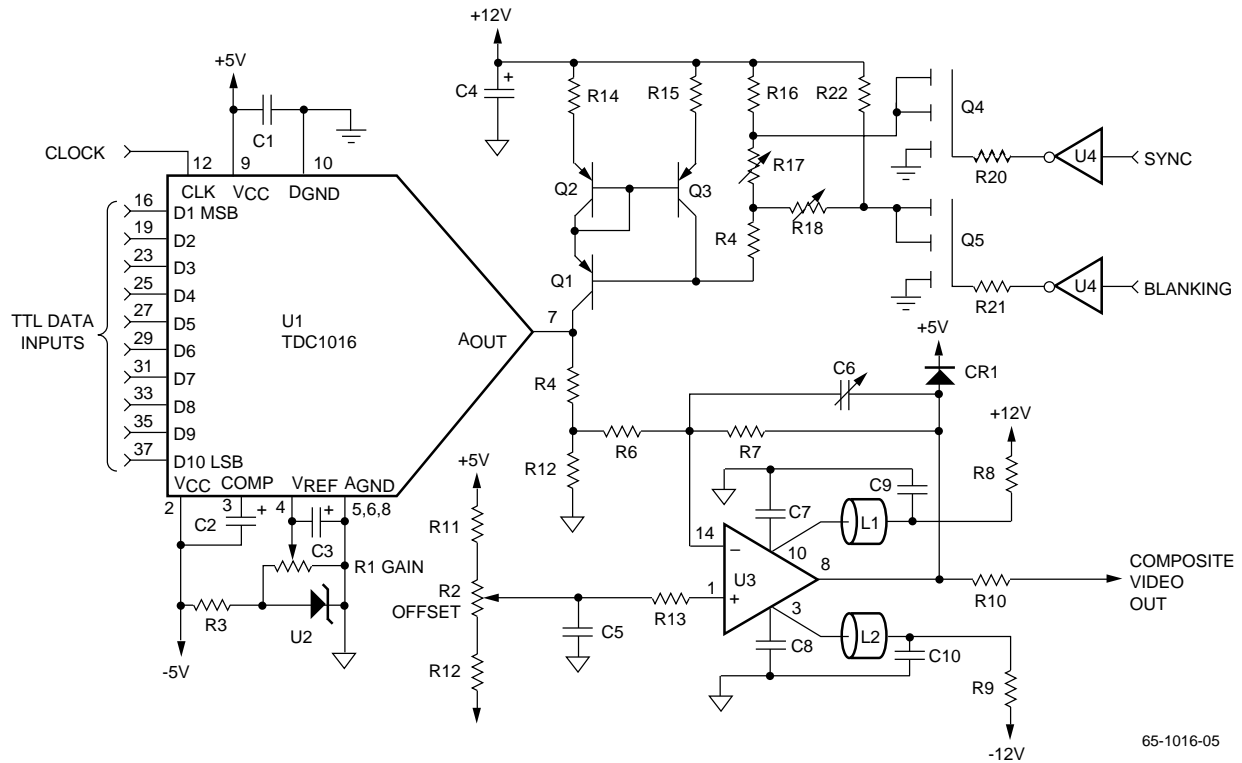

65-1016-05

Figure 5. Typical Interface Circuit

Table 1. Bill of Materials

Resistors			
R1	5K	1/4W	10-turn
R2	1K	1/4W	10-tum
R3	1K	1/4W	5%
R4	43	1/4W	5%
R5	33	1/4W	5%
R6	330	1/4W	5%
R7	750	1/4W	5%
R8, R9	10	1/4W	5%
R10	75	1/4W	2%
R11, R12	10K	1/4W	5%
R13	220	1/4W	5%
R14, R15	100	1/4W	5%
R16, R22	390	1/4W	5%
R17, R18	2K	1/4W	10-turn
R19	1K	1/4W	5%
R20, R21	1K	1/4W	5%

Capacitors		
C1	0.01 μ F	50V
C2	1.0 μ F	10V
C3	1.0 μ F	10V
C4	2.2 μ F	25V
C5	0.1 μ F	50V
C6	2–5pF	50V
C7	0.1 μ F	50V
C8	0.1 μ F	50V
C9	0.1 μ F	50V
C10	0.1 μ F	50V

RF Chokes	
L1, L2	Ferrite Beads

Diodes	
CR1	1N4001

Transistors	
Q1	2N2907
Q2	2N2907
Q3	2N2907
Q4	2N6660
Q5	2N6660

Integrated Circuits	
U1	TDC1016
U2	LM113
U3	HA2539
U4	SN7404

Mechanical Dimensions

40 Lead Sidebrazed Ceramic DIP

Symbol	Inches		Millimeters		Notes
	Min.	Max.	Min.	Max.	
A	.120	.175	3.05	4.44	
b1	.014	.023	.360	.580	7
b2	.040	.065	1.02	1.65	2
c1	.008	.015	.200	.380	7
D	1.970	2.030	50.04	51.56	
E	.575	.610	14.60	15.49	
e	.100 BSC		2.54 BSC		4, 8
eA	.600 BSC		15.24 BSC		6
L	.125	.200	3.18	5.08	
Q	.025	.060	.63	1.52	3
S1	.005	—	.13	—	5
S2	.005	—	.13	—	

Notes:

1. Index area: a notch or a pin one identification mark shall be located adjacent to pin one. The manufacturer's identification shall not be used as pin one identification mark.
2. The minimum limit for dimension "b2" may be .023(.58mm) for leads number 1, 20, 21, and 40 only.
3. Dimension "Q" shall be measured from the seating plane to the base plane.
4. The basic pin spacing is .100 (2.54mm) between centerlines. Each pin centerline shall be located within $\pm .010$ (.25mm) of its exact longitudinal position relative to pins 1 and 40.
5. Applies to all four corners (leads number 1, 20, 21, and 40).
6. "eA" shall be measured at the centerline of the leads.
7. All leads – Increase maximum limit by .003(.08mm) measured at the center of the flat when lead finish is applied.
8. Thirty-eight spaces.

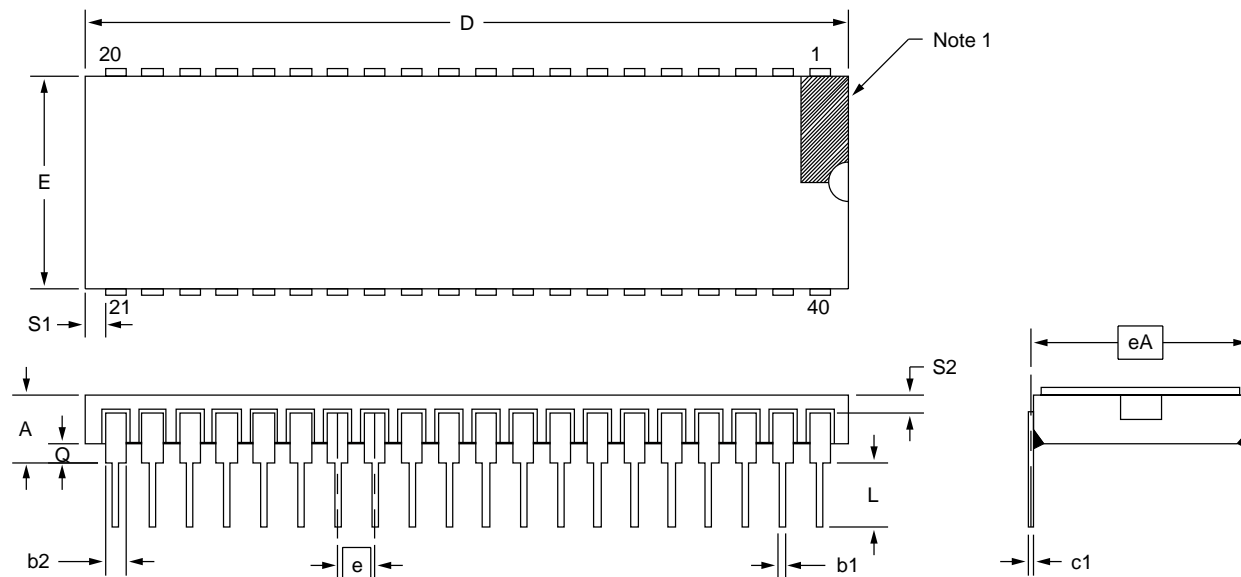

Mechanical Dimensions (continued)

24 Lead Sidebrazed Ceramic DIP

Symbol	Inches		Millimeters		Notes
	Min.	Max.	Min.	Max.	
A	.120	.175	3.05	4.44	
b1	.014	.023	.360	.580	7
b2	.040	.065	1.02	1.65	2
c1	.008	.015	.200	.380	7
D	1.180	1.220	29.97	30.99	
E	.575	.610	14.60	15.49	
e	.100 BSC		2.54 BSC		4, 8
eA	.600 BSC		15.24 BSC		7
L	.125	.200	3.18	5.08	
Q	.025	.060	.630	1.52	3
S1	.005	—	.13	—	5
S2	.005	—	.13	—	

Notes:

1. Index area: a notch or a pin one identification mark shall be located adjacent to pin one. The manufacturer's identification shall not be used as pin one identification mark.
2. The minimum limit for dimension "b2" may be .023(.58mm) for leads number 1, 12, 13, and 24 only.
3. Dimension "Q" shall be measured from the seating plane to the base plane.
4. The basic pin spacing is .100 (2.54mm) between centerlines. Each pin centerline shall be located within ± 0.010 (.25mm) of its exact longitudinal position relative to pins 1 and 24.
5. Applies to all four corners (leads number 1, 12, 13, and 24).
6. "eA" shall be measured at the centerline of the leads.
7. All leads – Increase maximum limit by .003(.08mm) measured at the center of the flat when lead finish is applied.
8. Twenty-two spaces.

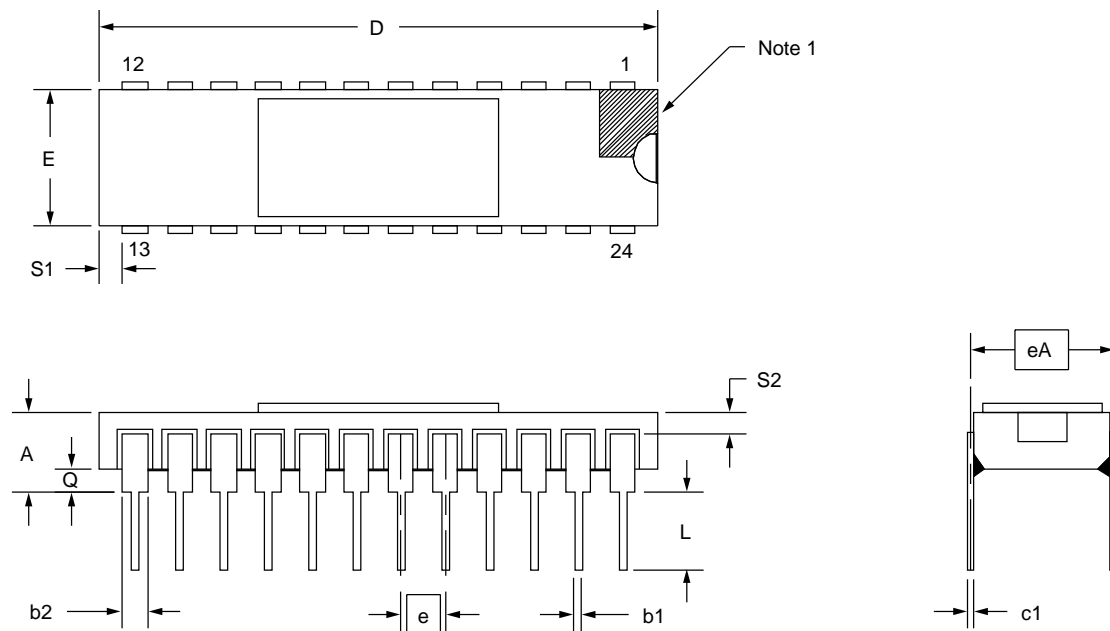

Ordering Information

Product Number	Temperature Range	Screening	Package	Package Marking
TDC1016J5CX	STD – T _A = 0°C to 70°C	Commercial	40 Pin Ceramic	1016J5CX
TDC1016J5AX	EXT – T _C = -55°C to 125°C	High Reliability	40 Pin Ceramic	1016J5AX
TDC1016J7CX	STD – T _A = 0°C to 70°C	Commercial	24 Pin Ceramic	1016J7CX
TDC1016J7AX	EXT – T _C = -55°C to 125°C	High Reliability	24 Pin Ceramic	1016J7AX

LIFE SUPPORT POLICY

FAIRCHILD'S PRODUCTS ARE NOT AUTHORIZED FOR USE AS CRITICAL COMPONENTS IN LIFE SUPPORT DEVICES OR SYSTEMS WITHOUT THE EXPRESS WRITTEN APPROVAL OF THE PRESIDENT OF FAIRCHILD SEMICONDUCTOR CORPORATION. As used herein:

1. Life support devices or systems are devices or systems which, (a) are intended for surgical implant into the body, or (b) support or sustain life, and (c) whose failure to perform when properly used in accordance with instructions for use provided in the labeling, can be reasonably expected to result in a significant injury of the user.
2. A critical component in any component of a life support device or system whose failure to perform can be reasonably expected to cause the failure of the life support device or system, or to affect its safety or effectiveness.