

TDC1049

High-Speed A/D Converter

9-Bit, 30 Msps

Features

- 30 Msps conversion rate, 15 MHz analog bandwidth
- 9-Bit resolution and linearity
- Sample-and-hold circuit not required
- Differential phase 0.5 degrees
- Differential gain 1.0%
- Overflow flag
- Single -5.2V power supply
- Differential ECL outputs
- Available in a 64-pin DIP, 68-contact LCC and 68-pin ceramic pin grid array

Applications

- Video data conversion
- Radar data conversion
- High-speed data acquisition

Description

The TDC1049 is a flash (full-parallel) analog-to-digital converter capable of converting analog signals with full-power frequency components up to 15 MHz into 9-bit words at rates up to 30 Msps (Megasamples Per Second). A sample-and-hold circuit is not required. All digital inputs and outputs are differential ECL.

The TDC1049 consists of 512 latching comparators, encoding logic and an output register. A differential convert signal controls the conversion operation. The outputs can be connected to give either true or inverted binary or offset two's complement formats.

Block Diagram

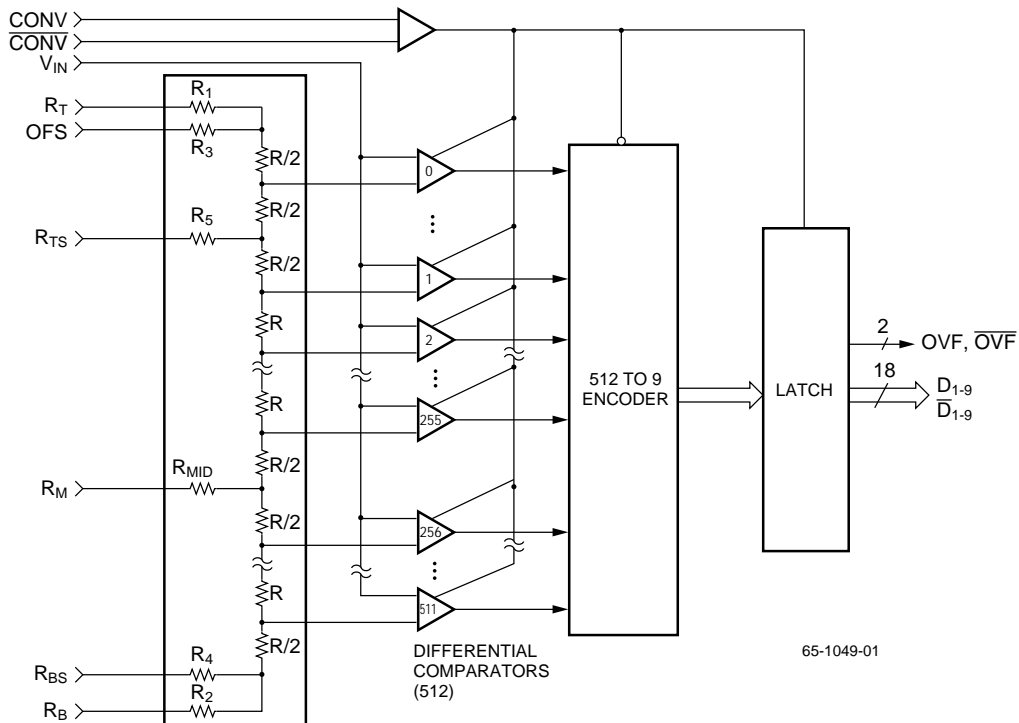

65-1049-01

Functional Description

General Information

The TDC1049 has three functional sections: a comparator array, encoding logic and output register. The comparator array compares the input signal with 512 reference voltages to produce an N-of-512 code or “thermometer” code.

The comparators referenced to voltages less than the input signal will be on and those referenced to voltages greater than the input signal will be off. The encoding logic converts the N-of-512 code into 9-bit binary data. The output register holds the output between updates.

Power

For optimum performance, separate analog and digital power, VEEA and VEED should be supplied to the TDC1049. Separate analog and digital power supplies or a common supply with separate analog and digital paths and high-frequency decoupling can be used. The return path for the current drawn from VEEA and VEED is AGND and DGND, respectively. The returns AGND and DGND should also be kept separate and connected together at the power supply terminals. It is recommended that provisions be made on the printed circuit board for shorting jumpers between analog and digital ground as close to the A/D converter as possible. The installation of the jumpers depends upon the printed circuit board layout and overall system performance once the system is in operation. The voltage difference between VEEA and VEED must be less than +0.1V. The same voltage difference limit applies to the difference between AGND and DGND. All power and ground inputs to the converter must be connected.

Reference

The TDC1049 converts analog signals in the range $V_{RB} < V_{IN} < V_{RT}$ into digital form. V_{RB} (the voltage applied to R_B) at the bottom of the reference resistor chain, and V_{RT} (the voltage applied to R_T) at the top of the reference resistor chain, should both be between +0.1V and -2.1V. Within that range, V_{RT} must be more positive than V_{RB} . The linearity specification is based upon a 2.0V difference between V_{RT} and V_{RB} . The nominal voltages are $V_{RT} = 0.0V$ and $V_{RB} = -20V$. To avoid damage to the converter, the voltage across V_{RT} and V_{RB} must not exceed 2.2V. A decoupling capacitor is recommended between R_B and AGND. Noise introduced at this point, as well as the other reference inputs (R_T , R_{TS} , R_M , R_{BS} , OFS), may result in encoding errors.

A midpoint tap, R_M , allows the converter to be adjusted for optimum integral linearity. It can also be used to achieve a nonlinear transfer function, but adjustment of R_M is not required to meet 9-bit linearity. If this node is driven by external circuitry, it should be driven from a low-impedance source; if not used, it must be left open.

Parasitic resistances, R_1 and R_2 , introduce offset errors at the top and bottom of the reference resistor chain. Sense points, R_{TS} , R_{BS} and OFS, may be used to reduce the effect of these offset errors. Overflow Sense (OFS) may be used to reduce the effect of the offset at the overflow (most positive) comparator whenever the Overflow (OVF, \overline{OVF}) flags are used. Sense points are not required for 9-bit linearity and, if not used, they must be left open.

Convert

The TDC1049 requires a differential ECL clock (CONV and \overline{CONV}) signal. The conversion occurs (the comparators are latched) within t_{STO} (Sampling Time Offset) of the rising edge of CONV. The 512 to 9 encoding is performed on the falling edge of the CONV signal. The coded result is transferred to the output register on the next rising edge of CONV. Data for sample N is available at the output t_D (Output Delay Time) after the rising edge of sample N+1.

Analog Input

The TDC1049 uses latching comparators which are connected to the analog inputs V_{IN} . For optimal performance, the source impedance of the driver amplifier should be less than 25 Ω . The input signal will not damage the TDC1049 if it remains within the range of VEEA to +0.5V. If the input signal is between the V_{RT} and V_{RB} , the output will be a binary number between 0 and 511 inclusive. All five analog inputs must be connected.

Outputs

The outputs of the TDC1049 are differential ECL. The recommended pull-down resistance is 500 Ω to -2V, or a 220/330 Ω termination between DGND and VEED. The OVF signal indicates that the analog input has exceeded the threshold of the most positive comparator. Data is held valid at the output register for at least t_{HO} (Output Hold Time) after the rising edge of CONV. New data becomes valid t_D after the rising edge of CONV.

No Connects

There are several pins labeled NC (No Connect). These pins are not connected internally and may be either left open or connected to analog ground to aid heat transfer from the package and to reduce electrical noise.

Pin Assignments

64 Lead Sidebraced Ceramic DIP

Pin	Name	Pin	Name	Pin	Name	Pin	Name
1	D ₈	17	V _{EEA}	33	D ₂	49	V _{IN}
2	D ₇	18	NC	34	D ₁ (MSB)	50	V _{IN}
3	D ₇	19	V _{EEA}	35	D ₁ (MSB)	51	AGND
4	D ₆	20	NC	36	OVF	52	AGND
5	D ₆	21	NC	37	OVF	53	V _{IN}
6	D ₅	22	V _{EED}	38	D _{GND}	54	NC
7	D ₅	23	NC	39	D _{GND}	55	R _T
8	AGND	24	NC	40	R _{BS}	56	OFS
9	NC	25	AGND	41	R _B	57	R _{TS}
10	NC	26	NC	42	NC	58	D _{GND}
11	V _{EED}	27	NC	43	V _{IN}	59	CONV
12	NC	28	D ₄	44	NC	60	CONV
13	NC	29	D ₄	45	AGND	61	D _{GND}
14	V _{EEA}	30	D ₃	46	AGND	62	D ₉ (LSB)
15	NC	31	D ₃	47	V _{IN}	63	D ₉ (LSB)
16	NC	32	D ₂	48	R _M	64	D ₈

65-1049-02

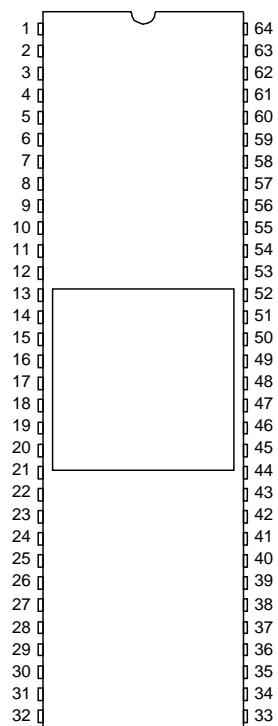

64 Lead Bottombraze Ceramic DIP

Pin	Name	Pin	Name	Pin	Name	Pin	Name
1	D ₈	17	R _M	33	D ₂	49	NC
2	D ₉ (LSB)	18	V _{IN}	34	D ₃	50	NC
3	D ₉ (LSB)	19	AGND	35	D ₃	51	V _{EEA}
4	D _{GND}	20	AGND	36	D ₄	52	NC
5	CONV	21	NC	37	D ₄	53	NC
6	CONV	22	V _{IN}	38	NC	54	V _{EED}
7	D _{GND}	23	NC	39	NC	55	NC
8	R _{TS}	24	R _B	40	AGND	56	NC
9	OFS	25	R _{BS}	41	NC	57	AGND
10	R _T	26	D _{GND}	42	NC	58	D ₅
11	NC	27	D _{GND}	43	V _{EED}	59	D ₅
12	V _{IN}	28	OVF	44	NC	60	D ₆
13	AGND	29	OVF	45	NC	61	D ₆
14	AGND	30	D ₁ (MSB)	46	V _{EEA}	62	D ₇
15	V _{IN}	31	D ₁ (MSB)	47	NC	63	D ₇
16	V _{IN}	32	D ₂	48	V _{EEA}	64	D ₈

65-1049-03

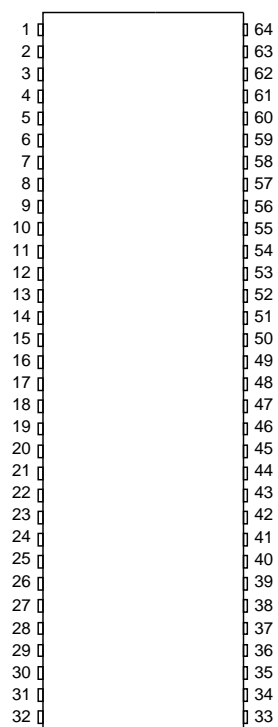

Pin Assignments (continued)

68 Lead LCC

Pin	Name	Pin	Name	Pin	Name	Pin	Name
1	D ₈	18	V _{EEA}	35	D ₂	52	R _M
2	D ₇	19	NC	36	D ₂	53	V _{IN}
3	D ₇	20	V _{EEA}	37	D ₁ (MSB)	54	V _{IN}
4	D ₆	21	V _{EEA}	38	D ₁ (MSB)	55	AGND
5	D ₆	22	V _{EED}	39	O _{VF}	56	NC
6	D ₅	23	NC	40	O _{VF}	57	AGND
7	D ₅	24	NC	41	D _{GND}	58	V _{IN}
8	NC	25	NC	42	NC	59	R _T
9	AGND	26	NC	43	R _B S	60	NC
10	NC	27	AGND	44	R _B	61	O _F S
11	NC	28	NC	45	NC	62	R _T S
12	NC	29	NC	46	V _{IN}	63	CONV
13	V _{EED}	30	NC	47	NC	64	CONV
14	V _{EEA}	31	D ₄	48	AGND	65	D _{GND}
15	NC	32	D ₄	49	AGND	66	D ₉ (LSB)
16	V _{EEA}	33	D ₃	50	V _{IN}	67	D ₉ (LSB)
17	NC	34	D ₃	51	NC	68	D ₈

65-1049-04

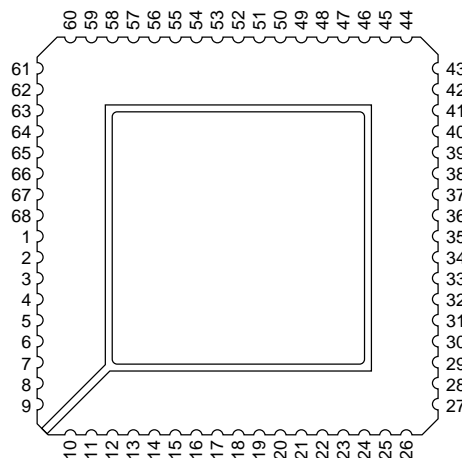

68 Lead Ceramic Pin Grid Array

Pin	Name	Pin	Name	Pin	Name	Pin	Name
A2	NC	B9	V _{EEA}	F10	D ₈	K4	AGND
A3	V _{EED}	B10	NC	F11	D ₇	K5	V _{IN}
A4	NC	B11	AGND	G1	D ₁ (MSB)	K6	V _{IN}
A5	NC	C1	NC	G2	D ₁ (MSB)	K7	NC
A6	NC	C2	NC	G10	D ₉ (LSB)	K8	AGND
A7	NC	C10	D ₅	G11	D ₈	K9	V _{IN}
A8	NC	C11	NC	H1	O _{VF}	K10	R _T S
A9	NC	D1	D ₄	H2	O _{VF}	K11	CONV
A10	V _{EED}	D2	D ₄	H10	D _{GND}	L2	NC
B1	NC	D10	D ₆	H11	D ₉ (LSB)	L3	NC
B2	AGND	D11	D ₅	J1	NC	L4	AGND
B3	V _{EEA}	E1	D ₃	J2	D _{GND}	L5	R _M
B4	NC	E2	D ₃	J10	CONV	L6	NC
B5	V _{EEA}	E10	D ₇	J11	D _{GND}	L7	V _{IN}
B6	V _{EEA}	E11	D ₆	K1	R _B S	L8	AGND
B7	V _{EEA}	F1	D ₂	K2	R _B	L9	R _T
B8	NC	F2	D ₂	K3	V _{IN}	L10	O _F S

65-1049-05

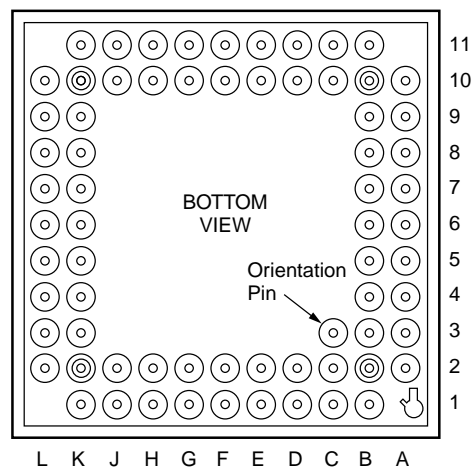

Pin Definitions

Pin Name	Pin Number				Value	Pin Function Description
	Bottom-brazed DIP	Sidebrazed DIP	LCC	PGA		
VEEA	46, 48, 51	14,17,19	14, 16, 18, 20, 21	B9, B7, B6, B5	-5.2V	Analog Supply Voltage
VEED	43, 54	11, 22	13, 22	A3, A10	-5.2V	Digital Supply Voltage
DGND	4, 7, 26, 27	38, 39, 58, 61	41, 65	J2, J11, H10	0.0V	Digital Ground
AGND	13, 14, 19, 20, 40, 57	8, 25, 45, 46, 51, 52	9, 27, 48, 49, 55, 57	B2, K4, L4, K8, L8,	0.0V	Analog Ground
RT	10	55	59	L9	0.0V	Reference Resistor, Top
RTS	8	57	62	K10	0.0V	Reference Resistor, Top Sense
RB	24	41	44	K2	-2.0V	Reference Resistor, Bottom
RBS	25	40	43	K1	-2.0V	Reference Resistor, Bottom Sense
RM	17	48	52	L5	-1.0V	Reference Resistor, Midpoint
OFS	9	56	61	L10	0.0V	Overflow Sense
CONV	5	60	64	J10	ECL	Convert
$\overline{\text{CONV}}$	6	59	63	K11	ECL	Convert, Complement
VIN	12, 15, 16, 18, 22	43, 47, 49, 50, 53	46, 50, 53, 54, 58	K3, K5, K6, L7, K9	0V to -2V	Analog Signal Input
D ₁ MSB	30	35	38	G1	ECL	Most Significant Bit
D ₂ –D ₈	32, 34, 36, 58, 60, 62, 64	33, 31, 29, 7, 5, 3, 1	36, 34, 7, 5, 3, 1	F1, E1, D1, C10, D10, E10, F10	ECL	
D ₉ LSB	2	63	67	G10	ECL	Least Significant Bit
$\overline{\text{D}}_1$ MSB	31	34	37	G2	ECL	Most Significant Bit Complement
$\overline{\text{D}}_2$ – $\overline{\text{D}}_8$	33, 35, 37, 59, 61, 63, 1	32, 30, 28, 6, 4, 2, 64	35, 33, 31, 6, 4, 2, 68	F2, E2, D2, D11, E11, F11, G11	ECL	
$\overline{\text{D}}_9$ LSB	3	62	66	H11	ECL	Least Significant Bit Complement
OVF	28	37	40	H2	ECL	Overflow Output
$\overline{\text{OV}}\overline{\text{F}}$	29	36	39	H1	ECL	Overflow Output Complement
NC	11, 21, 23, 38, 39, 41, 42, 44, 45, 47, 49, 50, 52, 53, 55, 56	9, 10, 12, 13, 15, 16, 18, 20, 21, 23, 24, 26, 27, 42, 44, 54	8, 10, 11, 12, 15, 17, 19, 23, 24, 25, 26, 28, 29, 30, 42, 45, 47, 51, 56, 60	B1, C2, C1, J1, L2, L3, L6, K7, C11, B10, A9, B8, A8, A7, A6, A5, B4, A4, A2	Open	No Connect

Absolute Maximum Ratings (beyond which the device may be damaged)¹

Parameter	Min.	Max.	Unit
Supply Voltages			
VEED (measured to DGND)	-7.0	+0.5	V
VEEA (measured to AGND)	7.0	+0.5	V
AGND (measured to DGND)	-1.0	+1.0	V
VEEA (measured to VEED)	-0.5	+0.5	V
Input Voltages²			
CONV, $\overline{\text{CONV}}$ (measured to DGND)	+0.5	VEE	V
VIN, VRT, VRB (measured to AGND)	+0.5	VEE	V
VRT (measured to VRB)	-2.5	+2.5	V
Output			
Short-circuit duration (single output in HIGH state to ground)	Infinite		
Temperature			
Operating, case	-60	+140	°C
junction		+175	°C
Lead, soldering (10 seconds)		300	°C
Storage	- 65	+150	°C

Notes:

1. Absolute maximum ratings are limiting values applied individually while all other parameters are within specified operating conditions. Functional operation under any of these conditions is NOT implied.
2. Applied voltage must be current limited to specified range.

Operating Conditions

Parameter		Temperature Range						Units
		Standard			Extended			
		Min.	Nom.	Max.	Min.	Nom.	Max.	
VEED	Digital Supply Voltage (measured to DGND)	-4.9	-5.2	-5.5	-4.9	-5.2	-5.5	V
VEEA	Analog Supply Voltage (measured to AGND)	-4.9	-5.2	-5.5	-4.9	-5.2	-5.5	V
VAGND	Analog Ground Voltage (measured to DGND)	-0.1	0.0	+0.1	-0.1	0.0	+0.1	V
VEEA-VEED	Supply Voltage Differential	-0.1	0.0	+0.1	-0.1	0.0	+0.1	V
tPWL	CONV Pulse Width, LDW	12			12			ns
tPWH	CONV Pulse Width, HIGH	15			15			ns
VICM	Input Voltage, Common Mode	-0.5		-2.5	-0.5		-2.5	V
VIDF	Input Voltage, Differential	0.3		1.2	0.3		1.2	V
VIN	Input Voltage Range	VRB		VRT	VRB		VRT	V
VRT	Most Positive Reference Inputs ¹	-0.1	0.0	0.1	-0.1	0.0	+0.1	V
VRB	Most Negative Reference Input ¹	-1.9	-2.0	-2.1	-1.9	-2.0	-2.1	V
VRT-VRB	Voltage Reference Differential	1.8	2.0	2.2	1.8	2.0	2.2	V
TA	Ambient Temperature, Still Air	0		70				°C
TC	Case Temperature				-55		125	°C

Note:

1. VRT must be more positive than VRB, and the voltage reference differential must be within the specified range.

DC Electrical Characteristics

Parameter	Test Conditions	Temperature Range				Units				
		Standard		Extended						
		Min.	Max.	Min.	Max.					
IEE	Supply Current	VEED, VEEA = Max								
		TA = 0°C to 70°C				-950	mA			
		TA = 70°C				-750	mA			
		IC = - 55°C to 125° C					-1090	mA		
		TC = 125°C					-750	mA		
IREF	Reference Current	VRT, VRB = Nom				10	36	10	36	mA
RREF	Total Reference Resistance					56	200	56	200	Ω
RIN	Input Equivalent Resistance	VRT, VRB = Nom, VIN = VRB				16		16		KΩ
CIN	Analog Input Capacitance	VRT, VRB = Nom, VIN = VRB					160		160	pF
ICB	Input Constant Bias Current	VEEA = Max, VIN = 0V					500		750	μA
II	Input Current, CONV, $\overline{\text{CONV}}$	VEED = Max, VI = -0.7V					150		180	μA
VOL	Output Voltage, Logic LOW ¹	VEED = Nom					-1.6		-1.5	V
VOH	Output Voltage, Logic HIGH ¹	VEED = Nom				-0.95		-1.1		V
CI	Digital Input Capacitance	TA = 25°C, f = 1MHz					20		20	pF

Note:

1. Test Load = 500Ω to -2v on each output.

AC Electrical Characteristics

Parameter	Test Conditions	Temperature Range				Units				
		Standard		Extended						
		Min.	Max.	Min.	Max.					
FS	Maximum Conversion Rate	VEED, VEEA = Min				30		30		MspS
tSTO	Sampling Time Offset	VEED, VEEA = Min				-2	6	-2	6	ns
tD	Output Delay ¹	VEED, VEEA = Min					27		27	ns
tHO	Output Hold Time ¹	VEED, VEEA = Min				3		3		ns

Note:

1. Test Load = 500Ω to -2V on each output, CLOAD = 20pF.

Timing Diagrams

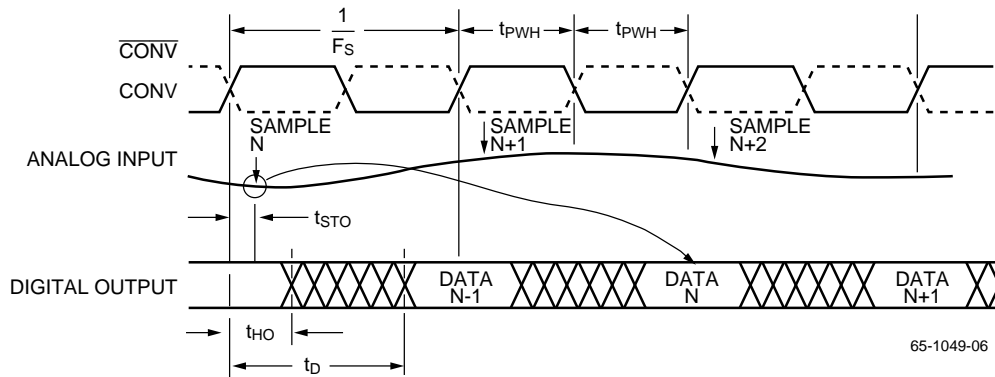

Figure 1. Timing Diagram

Timing Diagrams (continued)

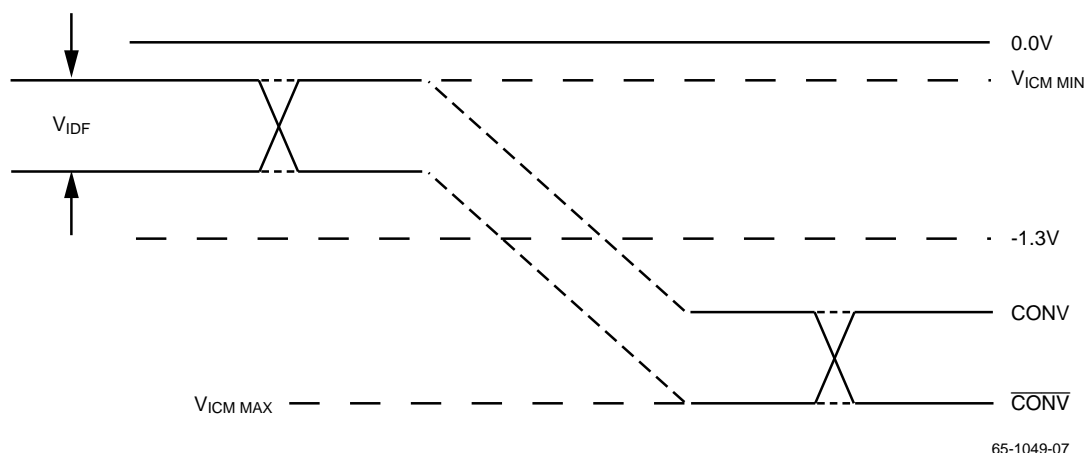

Figure 2. $\overline{\text{CONV}}$ ert, $\overline{\text{CONV}}$ ert Switching Levels

System Performance Characteristics

Parameter		Test Conditions	Temperature Range				Units
			Standard		Extended		
			Min.	Max.	Min.	Max.	
ELI	Linearity Error Integral, Independent	$V_{RT}, V_{RB} = \text{Nom}$		0.15		0.20	%
		$V_{RT}, V_{RB} = \text{Nom}, V_{RM} \text{ Adjusted}$		0.10		0.10	%
ELD	Linearity Error Differential	$V_{RT}, V_{RB} = \text{Nom}$		0.1		0.1	%
Q	Code Size	$V_{RT}, V_{RB} = \text{Nom}$	15	185	15	185	% Nominal
EOTS	Offset Error, Top	$V_{IN} = V_{RT}, \text{RTS Connected}$		± 4		± 4	mV
EOT	Offset Error, Top	$V_{IN} = V_{RT}$		30		30	mV
EOBS	Offset Error, Bottom	$V_{IN} = V_{RB}, \text{RBS Connected}$		± 4		± 4	mV
EOB	Offset Error, Bottom	$V_{IN} = V_{RB}$		-30		-30	mV
TCO	Offset Error, Temperature Coefficient			20		20	$\mu\text{V}/^\circ\text{C}$
tTR	Transient Response, Full-Scale			20		20	ns
BW	Bandwidth, Full Power Input	$\pm 0.9\text{dB}$ Frequency Response	15		15		MHz
SNR	Signal-to-Noise Ratio	30Mps Conversion Rate, 10MHz Bandwidth					
	Peak Signal/RMS Noise	1.25MHz Input	57		57		dB
		5.0MHz Input	53		53		dB
	RMS Signal/RMS Noise	1.25MHz Input	48		48		dB
5.0MHz Input		44		44		dB	
EAP	Aperture Error		50		50	ps	
DP	Differential Phase Error	$F_S = 4 \times \text{NTSC}$		0.5		0.5	Degree
DG	Differential Gain Error	$F_S = 4 \times \text{NTSC}$		1.5		1.5	%

Typical Performance Curves

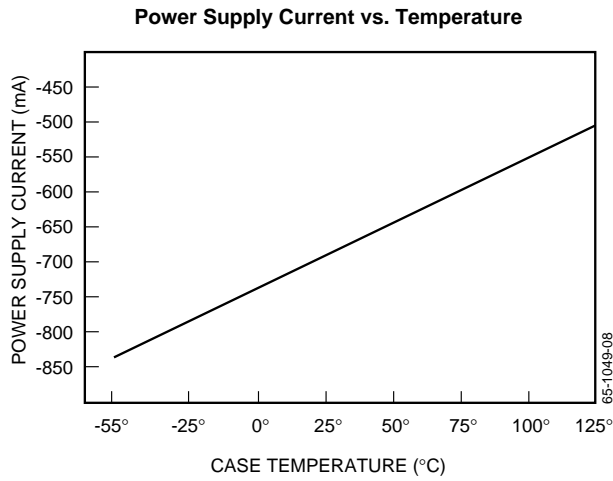

Figure 3. Power Supply Current vs. Temperature

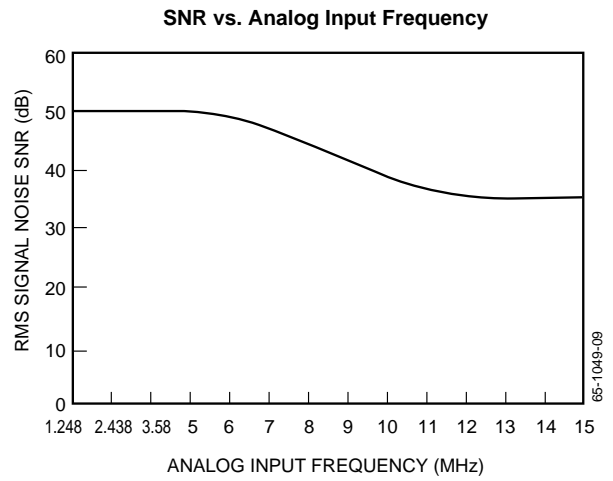
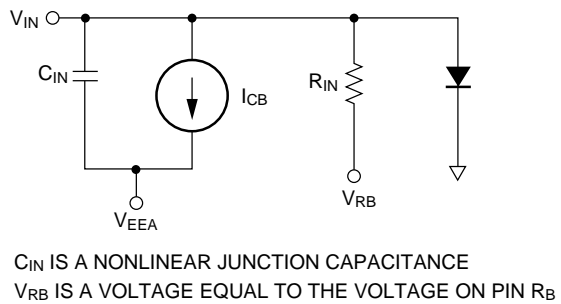
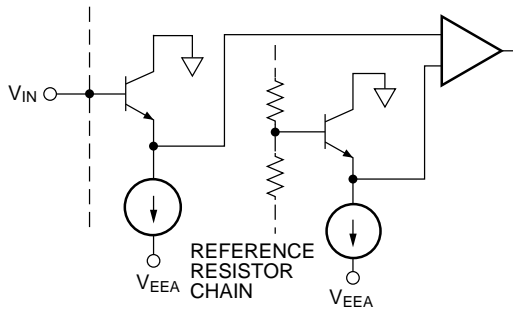

Figure 4. SNR vs. Analog Input Frequency

Equivalent Circuits



65-1049-10

Figure 5. Simplified Analog Input Equivalent Circuits

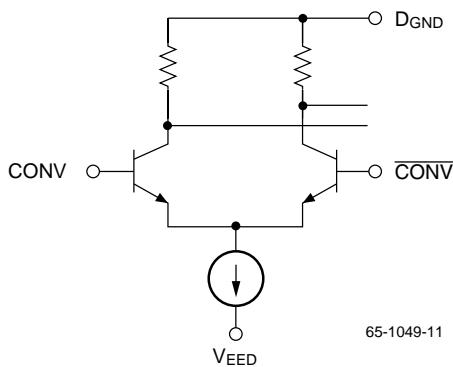

65-1049-11

Figure 6. Digital Input Equivalent Circuit

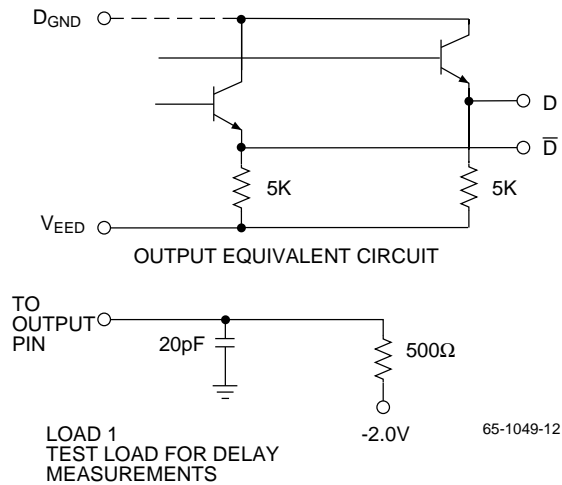

65-1049-12

Figure 7. Output Circuits

Output Coding Table¹

VIN	OVF	D1	D9
		MSB	LSB
+0.0039V	1	00000000	00000000
0.0000V	0	00000000	00000000
-0.0039V	0	00000001	00000001
•	•	•	•
•	•	•	•
•	•	•	•
-0.9980V	0	01111111	01111111
-1.0020V	0	10000000	10000000
-1.0059V	0	10000001	10000001
•	•	•	•
•	•	•	•
•	•	•	•
-1.9961V	0	11111110	11111110
-2.0000V	0	11111111	11111111

Note:

1. Voltages are code midpoints.

Standard Military Drawing

These devices are also available as products manufactured, tested, and screened in compliance with Standard Military Drawings (SMDs). The nearest vendor equivalent product is shown on the back page of this document; however, the applicable SMD is the sole controlling document defining the SMD product.

Notes:

Mechanical Dimensions

64 Lead Sidebrazed Ceramic DIP

Symbol	Inches		Millimeters		Notes
	Min.	Max.	Min.	Max.	
A	.120	.175	3.05	4.44	
B1	.015	.023	.38	.58	7
B2	.040	.065	1.02	1.65	2
C1	.008	.015	.20	.38	7
D	3.170	3.240	80.52	82.30	
E	.880	.910	14.60	15.48	
e	.100 BSC		2.54 BSC		4, 8
eA	.900 BSC		22.86 BSC		6
L	.125	.175	3.18	4.45	
Q	.025	.065	.63	1.65	3
S1	.005	—	.13	—	5
S2	.005	—	.13	—	

Notes:

1. Index area: a notch or a pin one identification mark shall be located adjacent to pin one. The manufacturer's identification shall not be used as pin one identification mark.
2. The minimum limit for dimension "b2" may be .023(.58mm) for leads number 1, 32, 33, and 64 only.
3. Dimension "Q" shall be measured from the seating plane to the base plane.
4. The basic pin spacing is .100 (2.54mm) between centerlines. Each pin centerline shall be located within ± 0.010 (.25mm) of its exact longitudinal position relative to pins 1 and 64.
5. Applies to all four corners (leads number 1, 32, 33, and 64).
6. "eA" shall be measured at the centerline of the leads.
7. All leads – Increase maximum limit by .003(.08mm) measured at the center of the flat when lead finish is applied.
8. Sixty-two spaces.

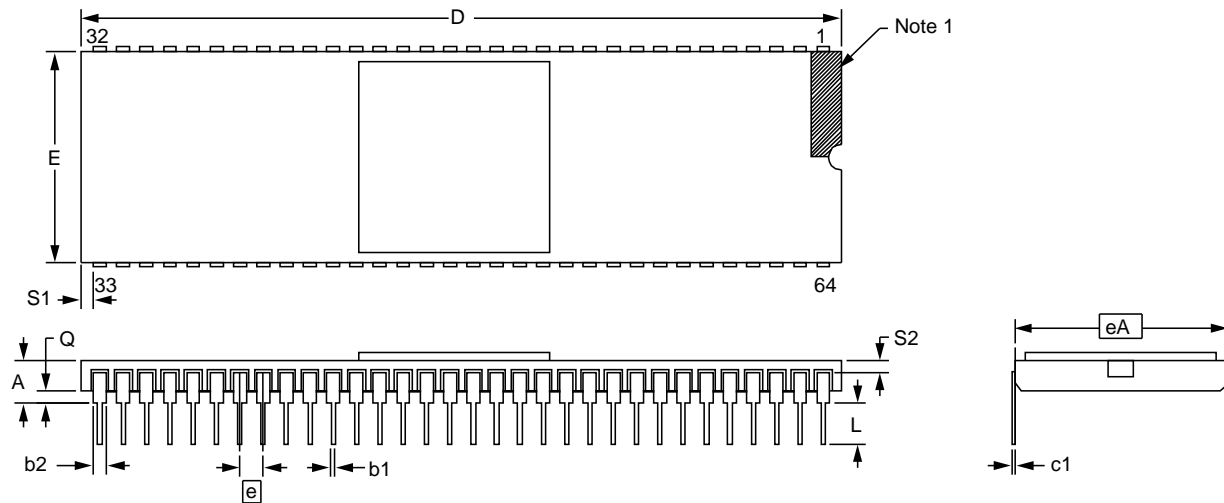

Mechanical Dimensions (continued)

64 Lead Bottombrazed Ceramic DIP

Symbol	Inches		Millimeters		Notes
	Min.	Max.	Min.	Max.	
A	.125	.200	3.18	5.08	
B1	.015	.023	.38	.58	7
B2	.040	.065	1.02	1.65	2
C1	.008	.015	.20	.38	7
D	3.110	3.240	80.00	82.30	
E	.790	.810	20.07	20.57	
e	.100 BSC		2.54 BSC		4, 8
eA	.900 BSC		22.86 BSC		6
L	.125	.175	3.18	4.45	
Q	.050	.100	1.27	2.54	3
S1	.005	—	.13	—	5
S2	.005	—	.13	—	

Notes:

1. Index area: a notch or a pin one identification mark shall be located adjacent to pin one. The manufacturer's identification shall not be used as pin one identification mark.
2. The minimum limit for dimension "b2" may be .023(.58mm) for leads number 1, 32, 33, and 64 only.
3. Dimension "Q" shall be measured from the seating plane to the base plane.
4. The basic pin spacing is .100 (2.54mm) between centerlines. Each pin centerline shall be located within ± 0.010 (.25mm) of its exact longitudinal position relative to pins 1 and 64.
5. Applies to all four corners (leads number 1, 32, 33, and 64).
6. "eA" shall be measured at the centerline of the leads.
7. All leads – Increase maximum limit by .003(.08mm) measured at the center of the flat when lead finish is applied.
8. Sixty-two spaces.

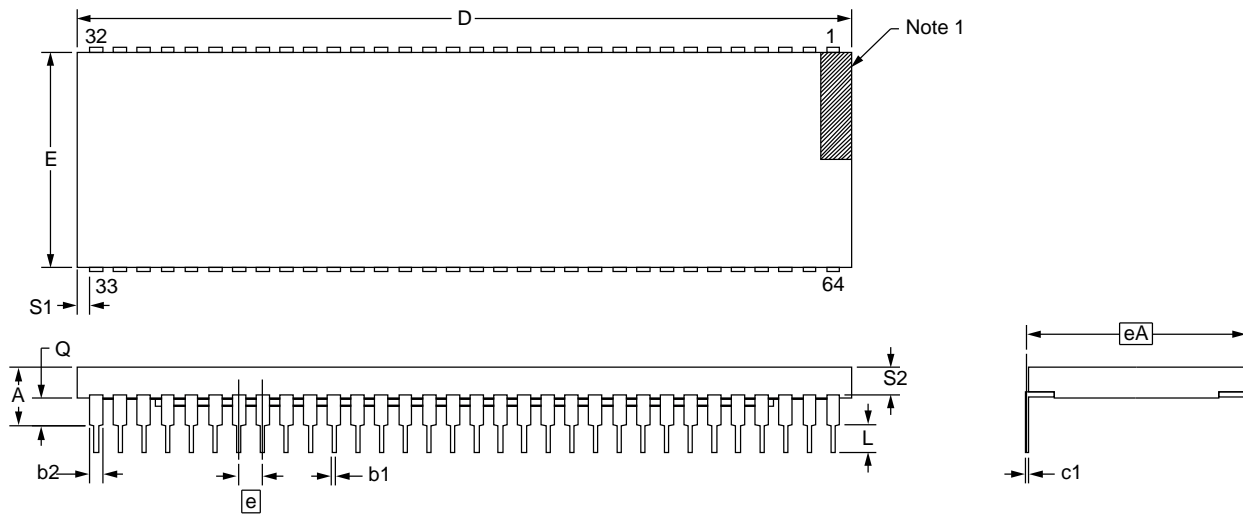

Mechanical Dimensions (continued)

68 Lead LCC

Symbol	Inches		Millimeters		Notes
	Min.	Max.	Min.	Max.	
A	.082	.110	2.08	2.79	3, 6
A1	.071	.093	1.83	2.39	3, 6
B1	.022	.028	.560	.710	2
B3	.006	.022	.150	.560	2,5
D/E	.938	.962	23.82	24.43	
D1/E1	.800 BSC		20.32 BSC		
D2/E2	.400 BSC		10.16 BSC		
e	.050 BSC		1.27 BSC		
h	.040 BSC		1.02 BSC		4
j	.020 BSC		.510 BSC		4
L1	.045	.055	1.14	1.40	
L2	.075	.095	1.91	2.41	
L3	.003	.015	.080	.380	5
ND/NE	17		17		
N	68		68		

Notes:

1. The index feature for terminal 1 identification, optical orientation or handling purposes, shall be within the shaded index areas shown on planes 1 and 2. Plane 1 terminal 1 identification may be an extension of the length of the metallized terminal which shall not be wider than the B1 dimension.
2. Unless otherwise specified, a minimum clearance of .015 inch (0.38mm) shall be maintained between all metallized features (e.g., lid, castellations, terminals, thermal pads, etc.).
3. Dimension "A" controls the overall package thickness. The maximum "A" dimension is the package height before being solder dipped.
4. The corner shape (square, notch, radius, etc.) may vary at the manufacturer's option, from that shown on the drawing. The index corner shall be clearly unique.
5. Dimension "B3" minimum and "L3" minimum and the appropriately derived castellation length define an unobstructed three dimensional space traversing all of the ceramic layers in which a castellation was designed. Dimension "B3" maximum and "L3" maximum define the maximum width and depth of the castellation at any point on its surface. Measurement of these dimensions may be made prior to solder dripping.
6. Chip carriers shall be constructed of a minimum of two ceramic layers.

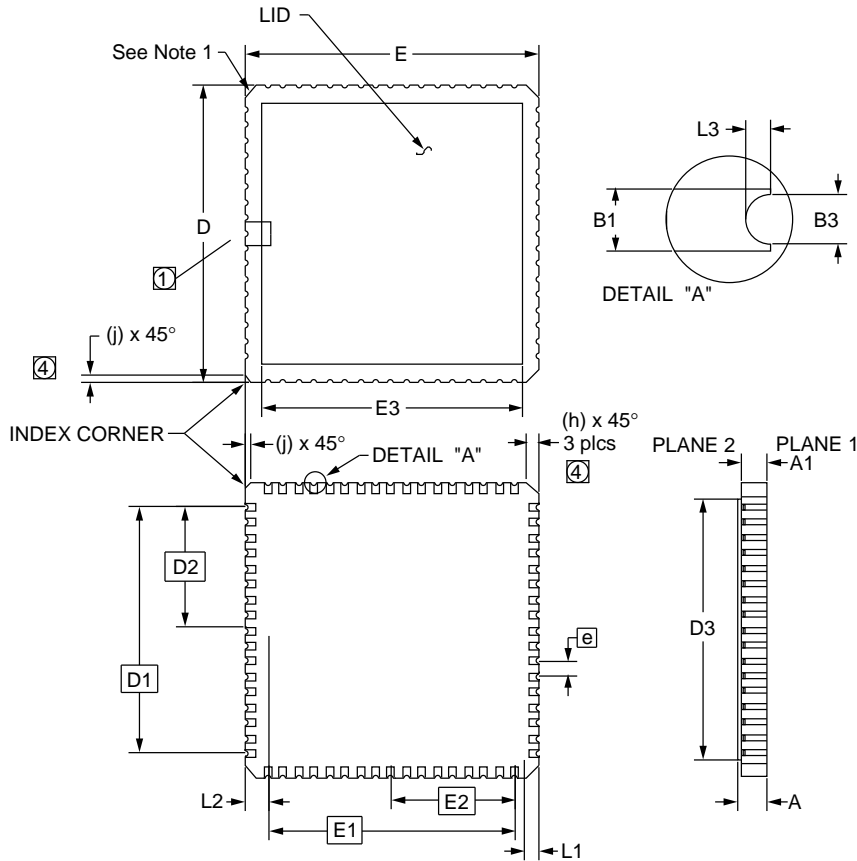

Mechanical Dimensions (continued)

68 Lead Plastic Grid Array

Symbol	Inches		Millimeters		Notes
	Min.	Max.	Min.	Max.	
A	.080	.125	2.03	3.18	
A1	.025	.060	0.64	1.52	
A2	.105	.180	2.67	4.57	
øB	.017	.020	0.43	0.51	
øB2	.050 NOM.		1.27 NOM.		
D	1.140	1.180	28.96	29.97	
D1	1.000 BSC		25.40 BSC		
e	.100 BSC		2.54 BSC		
L	.120	.140	3.05	3.56	
M	11		11		2
N	68		68		3
P	.003	—	.076	—	

Notes:

1. Pin #1 identifier shall be within shaded area shown.
2. Dimension "M" defines matrix size.
3. Dimension "N" defines the maximum possible number of pins.
4. Controlling dimension: inch.

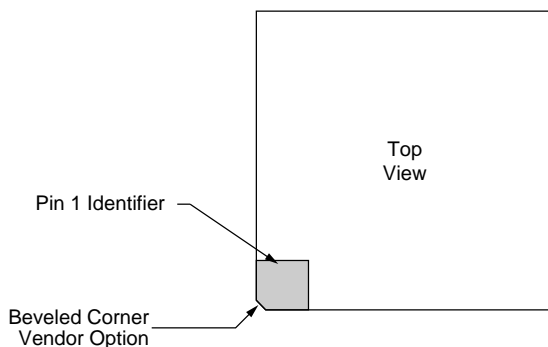
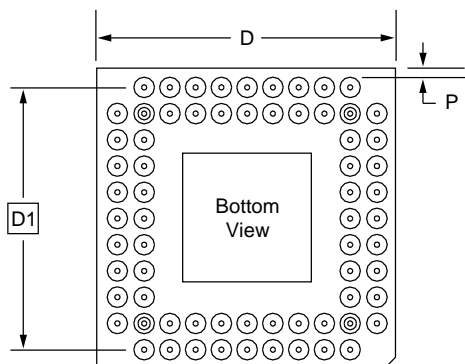
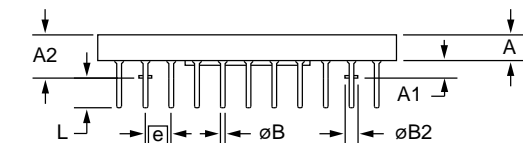

Ordering Information

Product Number	Temperature Range	Screening	Package	Package Marking
TDC1049J0C	STD - T _A = 0°C to 70°C	Commercial	64 Lead Sidebrazed Ceramic DIP	1049J0C
TDC1049J0V	EXT - T _C = -55°C to 125°C	MIL-STD-883	64 Lead Sidebrazed Ceramic DIP	1049J0V
5962-8853201XA	EXT - T _C = -55°C to 125°C	Per Standard Mil Drawing	64 Lead Sidebrazed Ceramic DIP	5962-8853201XA
TDC1049C1C	STD - T _A = 0°C to 70°C	Commercial	68-Lead LCC	1049C1C
TDC1049C1V	EXT - T _C = -55°C to 125°C	MIL-STD-883	68-Lead LCC	1049C1V
5962-8853201ZA	EXT - T _C = -55°C to 125°C	Per Standard Mil Drawing	68-Lead LCC	5962-8853201ZA
TDC1049G8C	STD - T _A = 0°C to 70°C	Commercial	68 Lead Ceramic PGA	1049G8C
TDC1049G8V	EXT - T _C = -55°C to 125°C	MIL-STD-B83	68 Lead Ceramic PGA	1049G8V

Standard Military Drawing	Nearest Equivalent Fairchild Product No.	Package
5962-8853201XA	TDC1049J0V	64 Lead Sidebrazed Ceramic DIP
5962-8853201YA	TDC1049J3V	64 Lead Bottombrazed Ceramic DIP
5962-8853201ZA	TDC1049C1V	68-Lead LCC
5962-8853201UA	TDC1049L1V	68-Lead LCC

LIFE SUPPORT POLICY

FAIRCHILD'S PRODUCTS ARE NOT AUTHORIZED FOR USE AS CRITICAL COMPONENTS IN LIFE SUPPORT DEVICES OR SYSTEMS WITHOUT THE EXPRESS WRITTEN APPROVAL OF THE PRESIDENT OF FAIRCHILD SEMICONDUCTOR CORPORATION. As used herein:

- Life support devices or systems are devices or systems which, (a) are intended for surgical implant into the body, or (b) support or sustain life, and (c) whose failure to perform when properly used in accordance with instructions for use provided in the labeling, can be reasonably expected to result in a significant injury of the user.
- A critical component in any component of a life support device or system whose failure to perform can be reasonably expected to cause the failure of the life support device or system, or to affect its safety or effectiveness.