

INTELLIGENT POWER SWITCH

ADVANCE DATA

- HIGH OUTPUT CURRENT
- ADJUSTABLE SHORT-CIRCUIT PROTECTION
- INTERNAL THERMAL PROTECTION WITH HYSTERESIS TO AVOID THE INTERMEDIATE OUTPUT LEVELS
- LARGE SUPPLY VOLTAGE RANGE: 8 TO 30V

DESCRIPTION

The TDE3237 is a monolithic amplifier designed for high-current and high-voltage applications, specially to drive lamps, relays and stepping motors.

The device is essentially blow-out proof. Current limiting is available to limit the peak output current to a safe value, the adjustment only requires one external resistor. In addition, thermal shut down is provided to keep the IC from overheating. If external dissipation becomes too great, the driver will

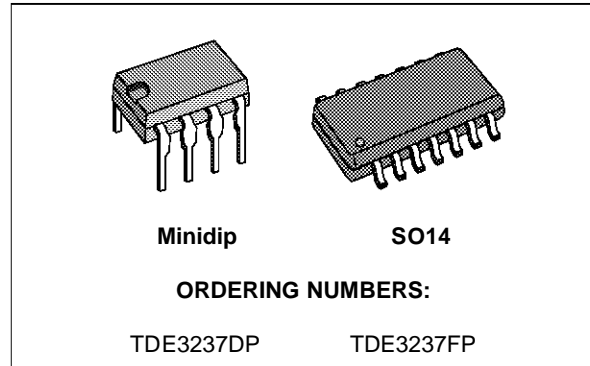

shut down to prevent excessive heating. The output is also protected from short-circuits with the positive power supply. The device operates over a wide range of supply voltages from standard $\pm 15V$ operational amplifier supplies down to the single 12V or 24V used for industrial electronic systems.

PIN CONNECTIONS

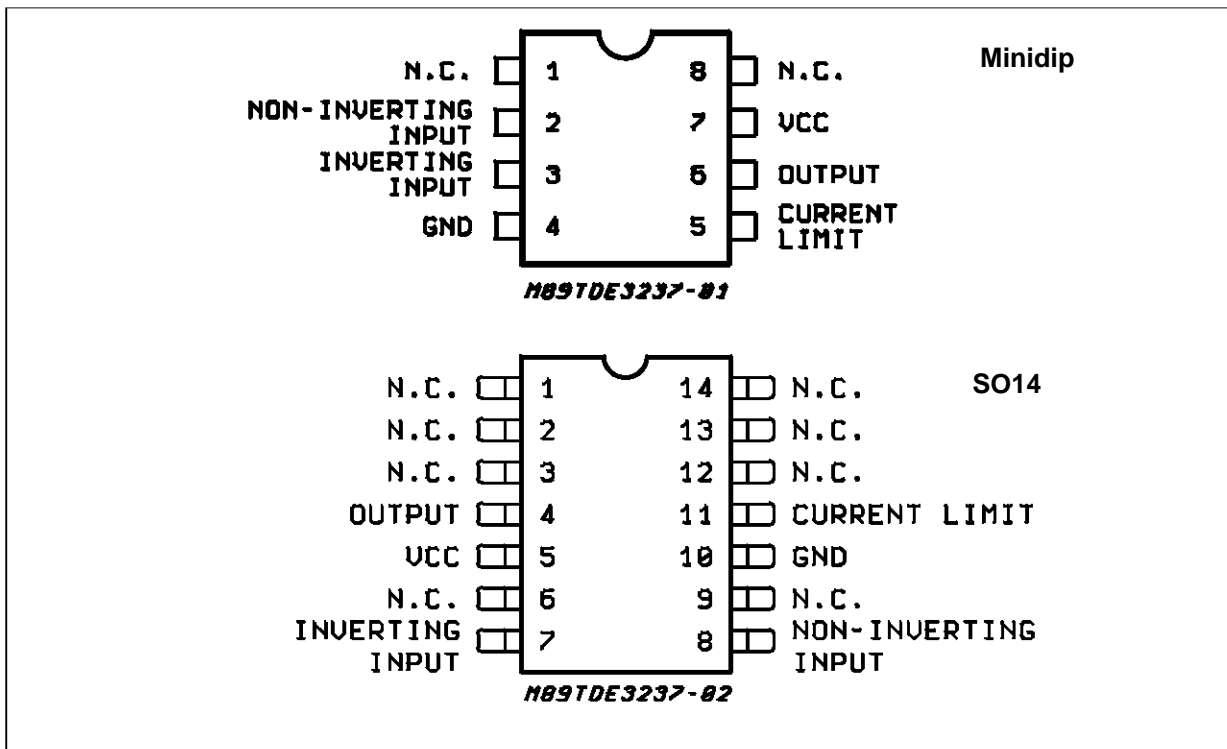

ABSOLUTE MAXIMUM RATINGS

| Symbol | Parameter | Value | Unit |
|-------------------|--------------------------------------|--------------------|------|
| V _{CC} | Supply Voltage | 36 | V |
| V _{ID} | Differential Input Voltage | 36 | V |
| V _I | Input Voltage | 36 | V |
| I _O | Output Current | 500 | mA |
| P _{tot} | Power Dissipation | Internally Limited | W |
| T _{stg} | Storage Temperature Range | - 65 to + 150 | °C |
| T _{oper} | Operating Free-air Temperature Range | - 25 to + 85 | °C |

THERMAL CHARACTERISTICS

| Symbol | Parameter | Value | Unit |
|----------------------|---|---------|----------|
| R _{th(j-c)} | Maximum Junction-case Thermal Resistance (note 1) | Minidip | 50 °C/W |
| R _{th(j-a)} | Maximum Junction-ambient Thermal Resistance (note 1) | Minidip | 120 °C/W |
| | Junction-ceramic Substrate (case glued to substrate) | SO14 | 90 °C/W |
| | Junction-ceramic Substrate (case glued to substrate, substrate temperature maintained constant) | SO14 | 65 °C/W |

Note : 1. Devices bonded on 40 cm glass-epoxy printed circuit 0.15cm thick with 4cm² of copper

SCHEMATIC DIAGRAM

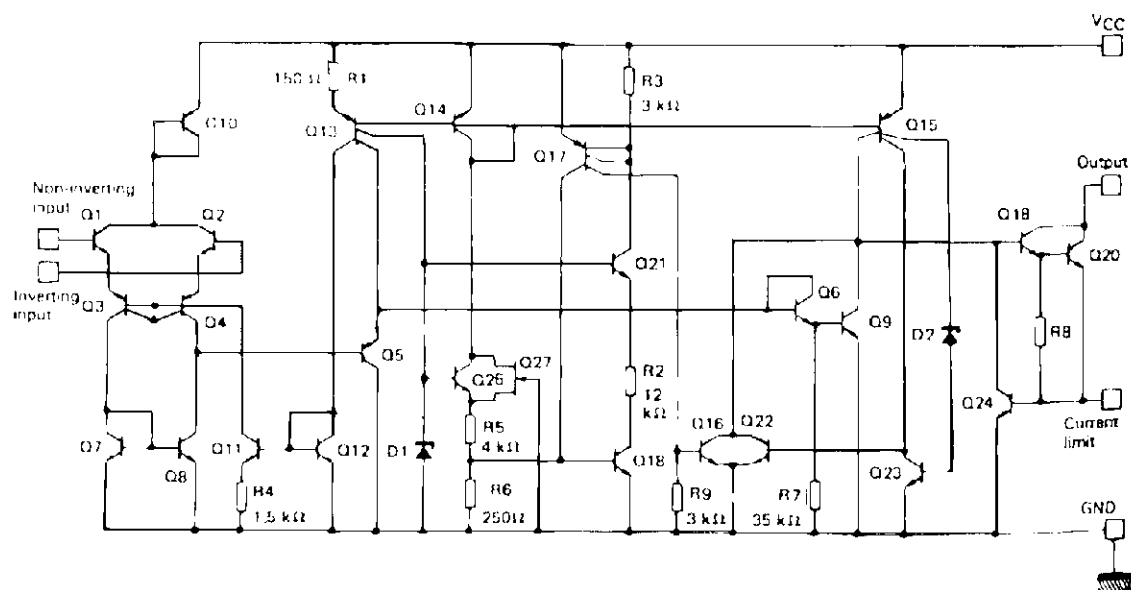

ELECTRICAL CHARACTERISTICS $T_{amb} = -25$ to $+85$ °C, $V_{CC} = 8$ to ≤ 30 V, unless otherwise specified (note 1).

| Symbol | Parameter | Min. | Typ. | Max. | Unit |
|--------------|---|------|------|------------|---------|
| V_{IO} | Input Offset Voltage - (note 3) | – | 2 | 50 | mV |
| I_{IB} | Input Bias Current | – | 0.1 | 1.5 | μ A |
| I_{CC} | Supply Current ($V_{CC} = +24$ V, $I_O = 0$) | – | 3 | 5 | mA |
| V_{CM} | Common-mode Input Voltage Range | 2 | – | $V_{CC}-2$ | V |
| I_{SC} | Short-circuit Current Limit ($T_{case} = +25$ °C, $R_{SC} = 3.3$ Ω) | – | 230 | – | -mA |
| $V_{CC}-V_O$ | Output Saturation Voltage (output high) ($R_{SC} = 0$, $V_{I+}-V_{I-} \geq 50$ mV, $I_O = 150$ mA) | – | 1 | 1.5 | V |
| I_{OL} | Low Level Output Current ($V_O = V_{CC} = +24$ V $T_{amb} = +25$ °C) | – | – | 100 | μ A |

Notes :

- 2) For operating at high temperature, the TDE3237, must be derated based on a + 150 C maximum junction temperature and a junction-ambient thermal as showed in the thermal characteristics data base.
- 3) The offset voltage given is the maximum value of input voltage required to drive the output voltage within 2 V of the ground or the supply voltage.

SIMPLIFIED SCHEMATIC

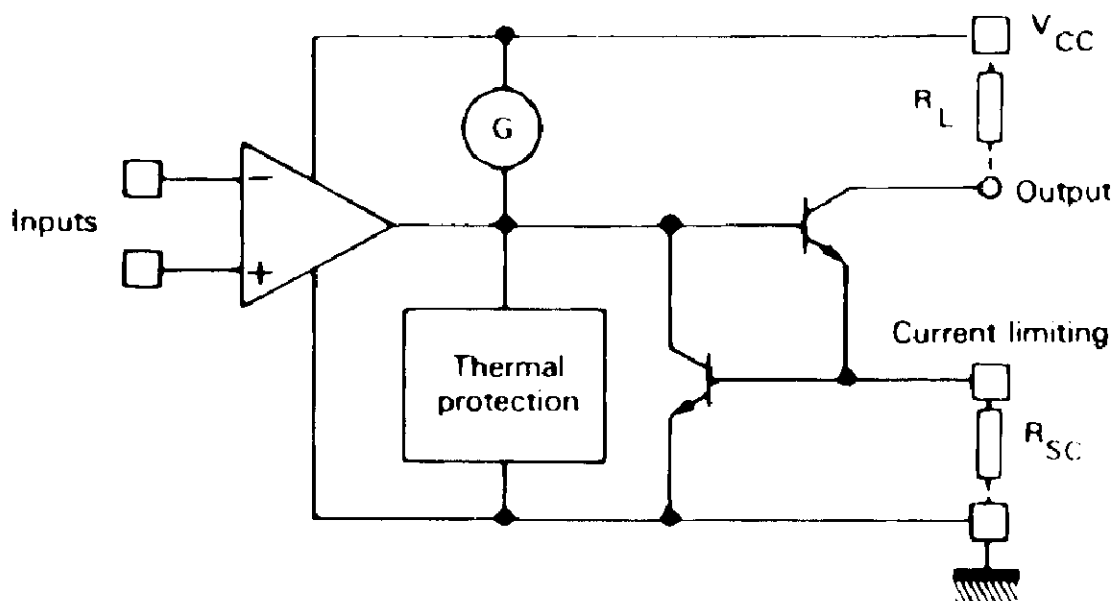

TYPICAL APPLICATION

BASIC CIRCUIT

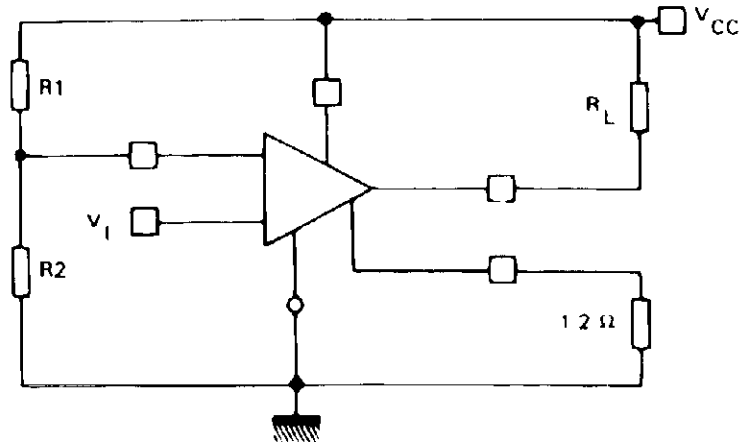

AVAILABLE OUTPUT CURRENT VERSUS LIMITING RESISTOR

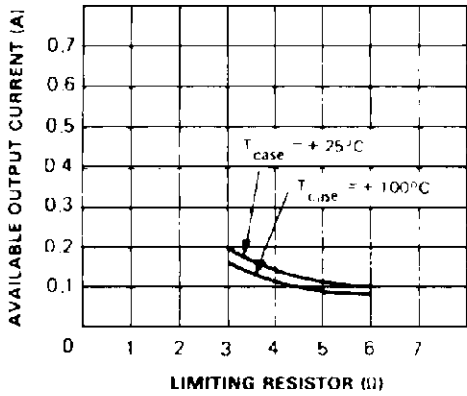

SUPPLY VOLTAGE VS MINIMUM LIMITING RESISTOR VALUE

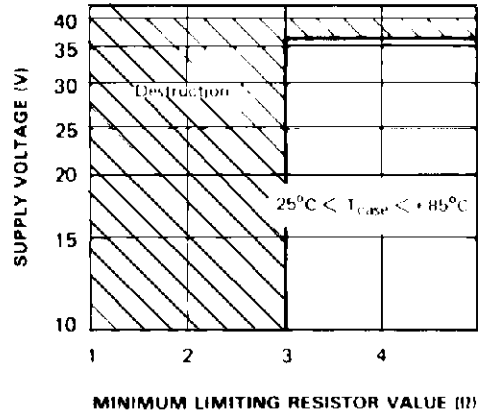

SATURATION OUTPUT VOLTAGE VERSUS CASE TEMPERATURE AND AVAILABLE OUTPUT CURRENT

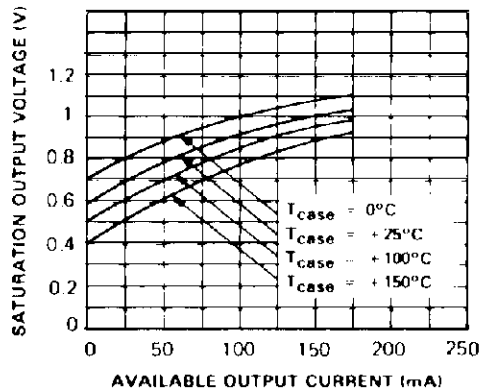

SO14 PACKAGE MECHANICAL DATA

| DIM. | mm | | | inch | | |
|------|-----------|------|------|-------|-------|-------|
| | MIN. | TYP. | MAX. | MIN. | TYP. | MAX. |
| A | | | 1.75 | | | 0.069 |
| a1 | 0.1 | | 0.25 | 0.004 | | 0.009 |
| a2 | | | 1.6 | | | 0.063 |
| b | 0.35 | | 0.46 | 0.014 | | 0.018 |
| b1 | 0.19 | | 0.25 | 0.007 | | 0.010 |
| C | | 0.5 | | | 0.020 | |
| c1 | 45 (typ.) | | | | | |
| D | 8.55 | | 8.75 | 0.336 | | 0.344 |
| E | 5.8 | | 6.2 | 0.228 | | 0.244 |
| e | | 1.27 | | | 0.050 | |
| e3 | | 7.62 | | | 0.300 | |
| F | 3.8 | | 4.0 | 0.15 | | 0.157 |
| L | 0.4 | | 1.27 | 0.016 | | 0.050 |
| M | | | 0.68 | | | 0.027 |
| S | 8 (max.) | | | | | |

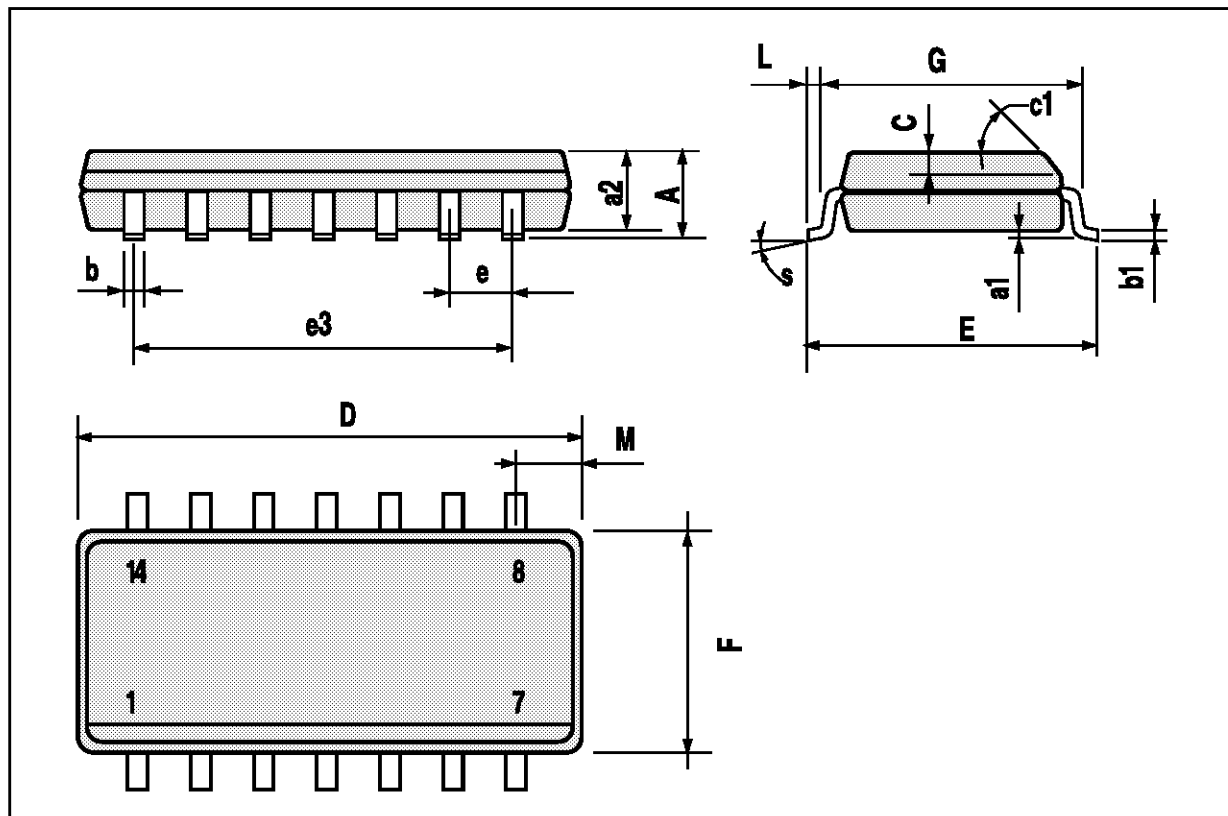

MINIDIP PACKAGE MECHANICAL DATA

| DIM. | mm | | | inch | | |
|------|-------|------|-------|-------|-------|-------|
| | MIN. | TYP. | MAX. | MIN. | TYP. | MAX. |
| A | | 3.32 | | | 0.131 | |
| a1 | 0.51 | | | 0.020 | | |
| B | 1.15 | | 1.65 | 0.045 | | 0.065 |
| b | 0.356 | | 0.55 | 0.014 | | 0.022 |
| b1 | 0.204 | | 0.304 | 0.008 | | 0.012 |
| D | | | 10.92 | | | 0.430 |
| E | 7.95 | | 9.75 | 0.313 | | 0.384 |
| e | | 2.54 | | | 0.100 | |
| e3 | | 7.62 | | | 0.300 | |
| e4 | | 7.62 | | | 0.300 | |
| F | | | 6.6 | | | 0.260 |
| I | | | 5.08 | | | 0.200 |
| L | 3.18 | | 3.81 | 0.125 | | 0.150 |
| Z | | | 1.52 | | | 0.060 |

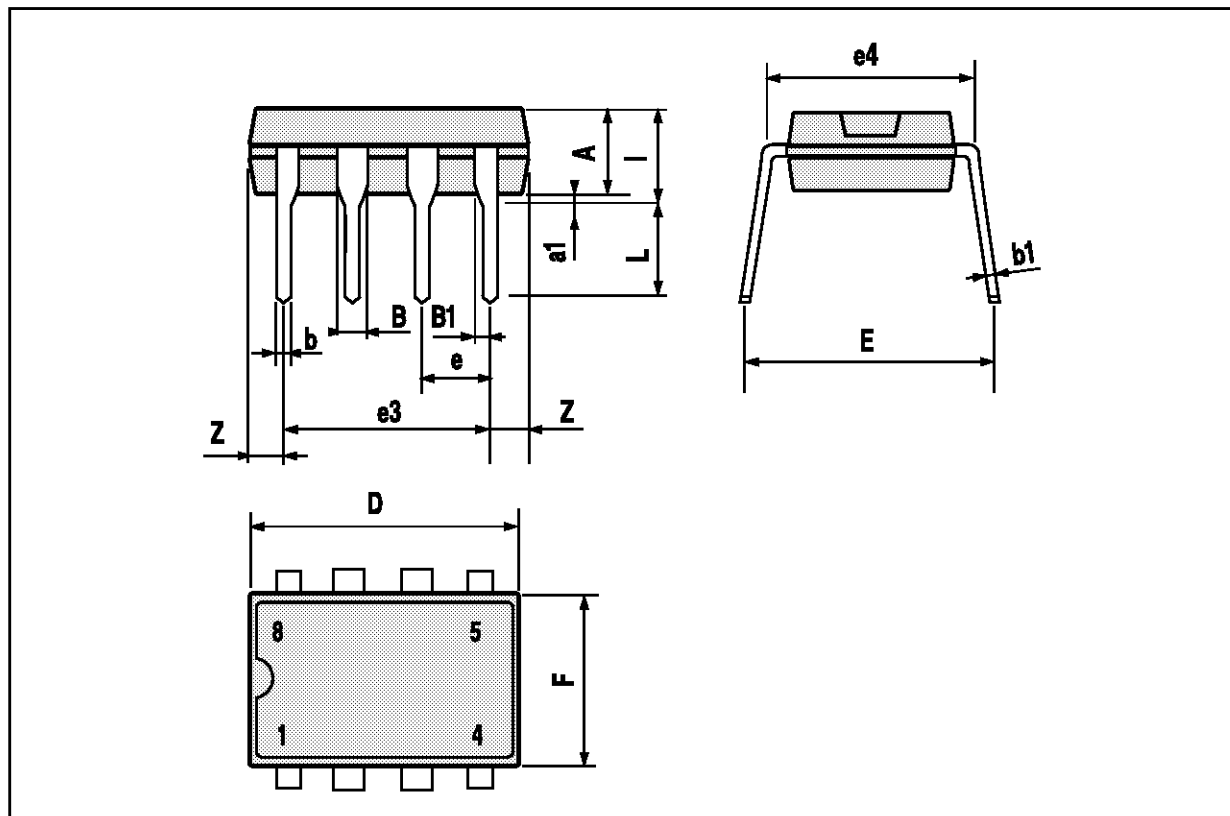

Information furnished is believed to be accurate and reliable. However, SGS-THOMSON Microelectronics assumes no responsibility for the consequences of use of such information nor for any infringement of patents or other rights of third parties which may result from its use. No license is granted by implication or otherwise under any patent or patent rights of SGS-THOMSON Microelectronics. Specifications mentioned in this publication are subject to change without notice. This publication supersedes and replaces all information previously supplied. SGS-THOMSON Microelectronics products are not authorized for use as critical components in life support devices or systems without express written approval of SGS-THOMSON Microelectronics.

© 1994 SGS-THOMSON Microelectronics - All Rights Reserved

SGS-THOMSON Microelectronics GROUP OF COMPANIES

Australia - Brazil - France - Germany - Hong Kong - Italy - Japan - Korea - Malaysia - Malta - Morocco - The Netherlands - Singapore - Spain - Sweden - Switzerland - Taiwan - Thailand - United Kingdom - U.S.A.