

**ADVANCED 2-HEAD PLAY-BACK
AND RECORD AMPLIFIER FOR VCR**

PRELIMINARY DATA

PLAY-BACK MODE

- LOW NOISE AND WIDE BAND AMPLIFIERS FOR 2 HEADS
- AUTOMATIC OFFSET CANCELLATION BETWEEN THE 2 SELECTED HEADS
- ONE PLAY-BACK OUTPUT WITHOUT AGC
- TWO PLAY-BACK OUTPUTS INCLUDING AGC (PHASE AND OPPOSITE PHASE)
- RECORD AMPLIFIER INHIBITION AND RECORD OUTPUT GROUNDED
- OUTPUT FOR TRACKING VIDEO INFORMATION (TRIV)

RECORD MODE

- ONE INTEGRATED I/I CONVERTER WITH ACCURATE CONTROL OF TRANSCONDUCTANCE
- AUTOMATIC PLAY-BACK/RECORD SWITCHING BY SCANNING OF RECORD SUPPLY
- PLAY-BACK LOOP INHIBITION

DESCRIPTION

The TEA5702A is an advanced two head record and play-back amplifier for VCR.

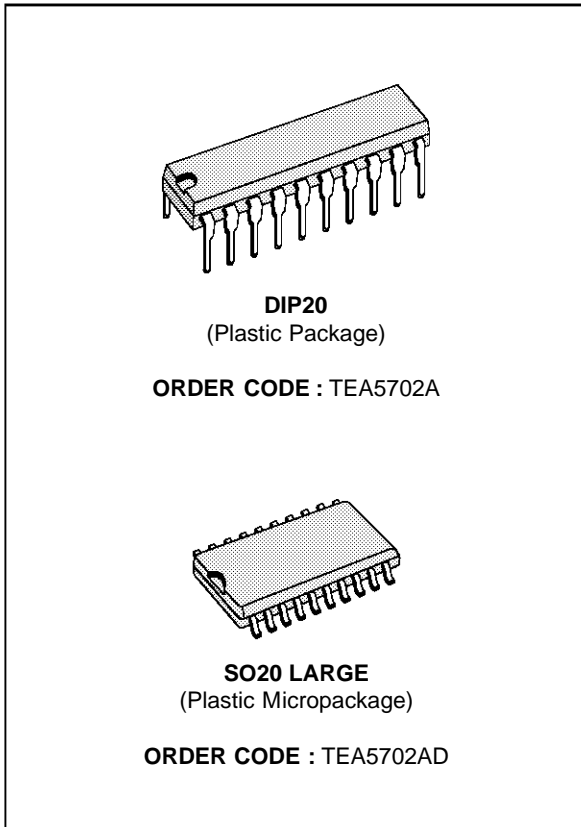

PIN DESCRIPTION

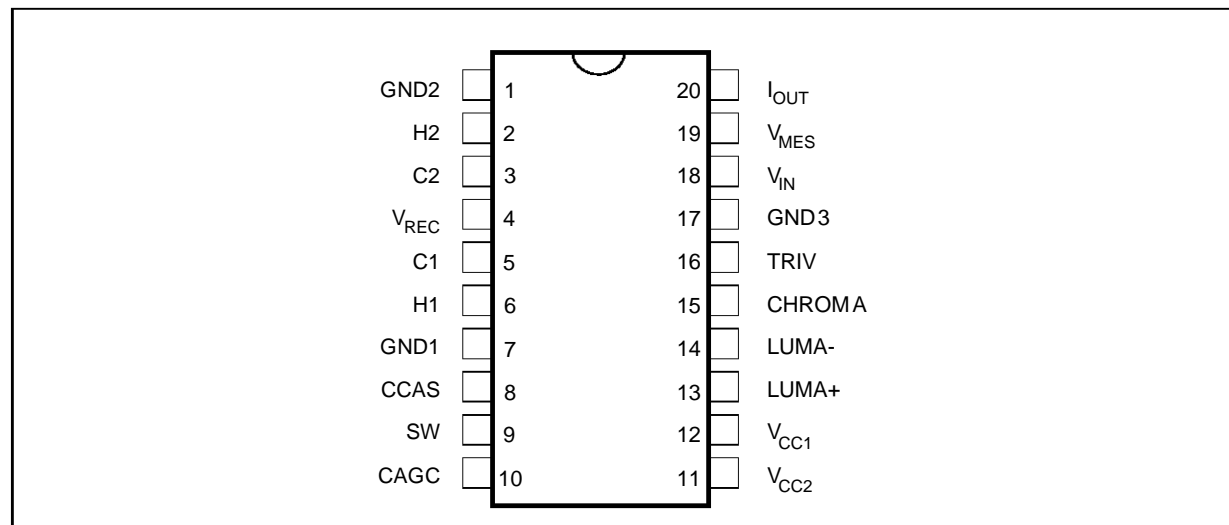

5702A-01.EPS

BLOCK DIAGRAM

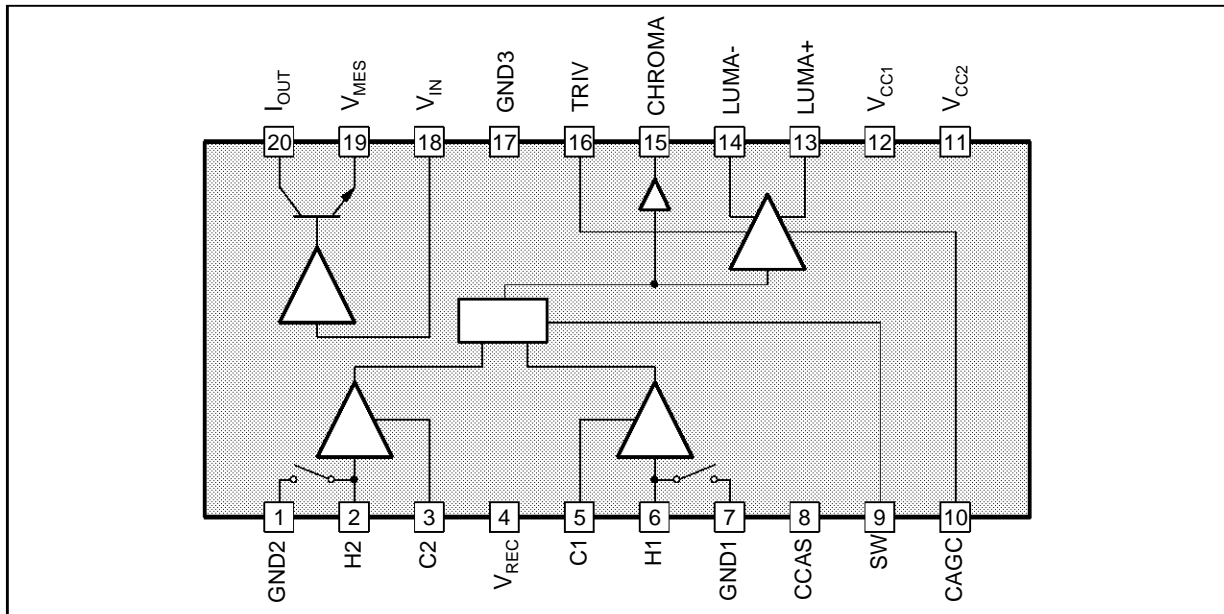

5702A-02.EPS

FUNCTIONAL DESCRIPTION

TEA5702A is intended for 2 heads VCR applications. It includes all the electrical functions necessary to achieve play-back and record processing for VHS applications.

High performance technology allows very low noise levels (current and voltage). In play-back mode a special feature suppresses the DC offset when switching two channels. Optimized play-back output stage gives to the TEA5702A large capability to drive directly a coaxial cable in order to reduce number of external components.

Three play-back outputs are available : one, dedicated to Chroma processing, is a 60dB voltage amplifier output, the two others, dedicated to Luma processing, are phase opposite signals with a constant AC output level of 200mV_{PP} at 3.8MHz signal.

A tracking information for video signal (TRIV) is Luma amplitude proportional and allows automatic phase correction.

An automatic scanning of record supply voltage permits TEA5702A automatically switching either in play-back or in record mode. The switching threshold voltage is fixed to a value which forbids high current peaking through the heads.

During play-back mode, record output is grounded via an internal transistor and during record mode preamplifiers are turned off.

There is one output current for the two heads, the DC current and the AC characteristics can be very precisely controlled with accurate external resistors. If recommended resistances are used, a ± 3% transconductance accuracy is guaranteed.

ABSOLUTE MAXIMUM RATING

Symbol	Parameter	Value	Unit
V _{CC}	Power Supply Voltage	6	V
V _{REC}	Power Supply Voltage Record	15	V
T _J	Junction Temperature	150	°C
T _{oper}	Operating Temperature	0, +70	°C

5702A-01.TBL

THERMAL DATA

Symbol	Parameter	Value	Unit
R _{th (j-a)}	Junction-ambient Thermal Resistance (Typ.)	70	°C/W

5702A-02.TBL

RECOMMENDED OPERATING CONDITIONS ($T_{amb} = 25^{\circ}\text{C}$)

Symbol	Parameter	Min.	Typ.	Max.	Unit
V_{CC}	Power Supply Voltage	4.75	5	5.25	V
V_{REC}	Power Supply Voltage Record	4.75	10	12.6	V
CAGC	Capacitance at Pin CAGC	4.7			nF

5702A-03.TBL

ELECTRICAL OPERATING CHARACTERISTICS ($T_A = 25^{\circ}\text{C}$ unless otherwise specified)**Power Consumption**

Parameter	Play-Back		Record (1)	
	Typ.	Max.	Typ.	Max.
V_{CC}	35mA	45mA	25mA	35mA
V_{REC}	0mA	0mA	45mA	55mA
Total Consumption (2)	$V_{CC} = 5, V_{REC} = 10$		530mW	
	$V_{CC} = 5.25, V_{REC} = 10.5$		760mW	

5702A-04.TBL

- Notes :**
1. $R1 = 10\Omega$
 2. Taking in account only the consumption through the IC.
A great care should be taken to the maximum power consumption : V_{REC} can be increased to 12.6V if the DC current flowing through the head is reduced. This can be done by increasing R1 value.

Play-back Mode $V_{CC} = 5\text{V}$, no load on Pins CHROMA, LUMA+, LUMA-

Symbol	Parameter	Test Conditions	Min.	Typ.	Max.	Unit
I_{CC1}	Supply Current		25	35	45	mA

CHROMA OUTPUT (no AGC)

G_{PB}	Pre-amplification Gain	Sinus wave 600 kHz 400mV _{PP} on output Input on Pin H1 or H2	56	60	62	dB
ΔG_{PB}	Gain Difference of Output Signal on Pin CHROMA between Channel 1 and Channel 2	Sinus wave 3.8MHz 0.4mV _{PP} on inputs H1 or H2			1.2	dB
e_N	Equivalent Input Voltage Noise Level (see note)	Input grounded via switching transistor on Pins H1, H2		0.6	0.85	nV/ $\sqrt{\text{Hz}}$
i_N	Equivalent Input Current Noise	Pins H1, H2		2	2.8	pA/ $\sqrt{\text{Hz}}$
CRT	Crosstalk	Sinus wave 3.8MHz 400 μV_{PP} , All switches combined			-40	dB
F_{LCPB} F_{HCPB}	Bandwidth Cut-off Frequency	-3dB attenuation 50 Ω in parallel on the input, 0dB at 600kHz Low High	8		0.1	MHz MHz
C_{IN}	Input Capacitance Pins H1, H2			30		pF
R_{IN}	Pre-amplifier Input Resistance Pins H1, H2		400	600	900	Ω
Z_{CPB}	Output Impedance	Sinus wave 1MHz, 400 μV_{PP} on input		30	50	Ω
V_{DCPB1}	DC Level		1.5	1.9	2.5	V
ΔV_{DC}	Head Switch Offset				100	mV
SH_{PB1}	Second Harmonic	Sinus wave 600kHz, 400 μV_{PP} on input		-45	-40	dB

LUMA+, LUMA- OUTPUTS (with AGC)

Z_{LPB}	Output Impedance	Sinus wave 1MHz, 400 μV_{PP} on input		30	50	Ω
V_{DCPB2}	DC Level		0.8	1.5	2.0	V

5702A-05.TBL

Note : These values can be adjusted to the application.

ELECTRICAL OPERATING CHARACTERISTICS ($T_A = 25^\circ\text{C}$ unless otherwise specified) (continued)**Play-back Mode** $V_{CC} = 5\text{V}$, no load on Pins CHROMA, LUMA+, LUMA-

Symbol	Parameter	Test Conditions	Min.	Typ.	Max.	Unit
LUMA+, LUMA- OUTPUTS (with AGC) (continued)						
V_{LPB}	Output Amplitude	Input signal $200\mu\text{V}_{PP}$ at 3.8MHz on Pins H1, H2	140	200	270	mV _{PP}
ΔV_{LPB}	AGC Control Sensitivity	Input signal $200\mu\text{V}_{PP}$ at +6dB or -5dB on Pins H1, H2	-2		+1	dB
SH_{PB2}	Second Harmonic Play-back Output	Input Signal 3.8MHz $400\mu\text{V}_{PP}$ on Pins H1, H2		-43	-35	dB

CAGC

I+	Positive Output Current on Pin CAGC	Input Signal 3.8MHz $200\mu\text{V}_{PP}$ on H1, 1V on Pin CAGC	15	30	45	μA
I-	Negative Output Current on Pin CAGC	Input Signal 3.8MHz $200\mu\text{V}_{PP}$ on H1, 3.5V on Pin CAGC	-50	-30	-15	μA

TRIV

R_{TRIV}	Downloading Resistance		20	40	80	k Ω
V_{TRIV1} V_{TRIV3} V_{TRIV4} V_{TRIV5}	Output Level	$V_{CHROMA} = 0\text{mV}_{PP}$ $V_{CHROMA} = 400\text{mV}_{PP}$ at 4.5MHz $V_{CHROMA} = 600\text{mV}_{PP}$ at 4.5MHz $V_{CHROMA} = 800\text{mV}_{PP}$ at 4.5MHz	0 2.6 3.3 3.6	3 3.7 4.2	1.2 3.4 4.1 4.5	V V V V
G_{TRIV1} G_{TRIV2}	Gain	$V_{CHROMA} = 0\text{mV}_{PP}$, 400mV_{PP} at 4.5MHz $V_{CHROMA} = 400\text{mV}_{PP}$, 600mV_{PP} at 4.5MHz		7.5 3.5		V/V _{PP} V/V _{PP}

5702A-06.TBL

Record Mode $V_{REC} = 10\text{V}$, $V_{CC} = 5\text{V}$, Load resistor 100Ω on Pin IOUT

Transconductance network defined by :

- $R1 = 10\Omega$ 1% Pins GND3/ V_{MES}
- $R2 = 1\text{k}\Omega$ 1% Pins V_{MES}/V_{IN}
- $R3 = 750\Omega$ 1% Pins V_{IN}

Symbol	Parameter	Test Conditions	Min.	Typ.	Max.	Unit
I_{REC} I_{CC2}	Current Supply	$V_{REC} = 10\text{V}$ $V_{CC} = 5\text{V}$		45 25	55 35	mA mA

IOUT

I_{max}	Max. Record Current	3.8MHz	35			mA _{PP}
TR	Transconductance	$V_{IN} = 300\text{mV}_{PP}$	110	140	170	mA/V
SH_{REC}	Second Harmonic	Output Current 30mA_{PP} at 3.8MHz		-48	-40	dB
F_{LCREC} F_{HCREC}	Bandwidth Cut-off Frequency	-3dB attenuation, 0dB at 3.8MHz Output current 30mA_{PP} Low High	8		0.1	MHz MHz

5706A-07.TBL

Switching Levels

Symbol	Parameter	Test Conditions	Min.	Typ.	Max.	Unit
V_{SWH}	Head Selection Pin SW	Head number 1 (high level)	2.4		V_{CC}	V
V_{SWL}		Head number 2 (low level)	0		1.5	V
I_{SWH}		Input current (high level)		20	50	μA
I_{SWL}		Output current (low level)		20	50	μA
t_{ON}	Selection Pin SW Transient Response	Delay time selection ON (output signal appears on Pin CHROMA)		250	1000	ns
t_{OFF}		Delay time selection OFF (output signal disappears on Pin CHROMA)		250	1000	ns

5702A-06.TBL

ELECTRICAL OPERATING CHARACTERISTICS ($T_A = 25^\circ\text{C}$ unless otherwise specified) (continued)
Switching Levels

Symbol	Parameter	Test Conditions	Min.	Typ.	Max.	Unit
V_{TH1}	Inhibition Threshold for Switching from Play-back to record on Pin V_{REC}	$V_{CC} = 5V$	0.15	0.3	0.5	V
V_{TH2}	Inhibition Threshold Hysteresis for Switching from Record to Play-back on Pin V_{REC}	$V_{CC} = 5V$		80		mV
t_1	Transient Response of Record Scanning on Pin V_{REC}	Delay from play-back to record (signal disappears on Pin CHROMA)		30		μs
t_2		Delay from record to play-back (signal appears on Pin CHROMA)		2*		ms
t_3		Delay from play-back to record (signal appears on Pin IOUT)		0.2		ms
t_4		Delay from record to play-back (signal disappears on Pin IOUT)		4*		ms

* Depending on capacitance on Pin V_{REC} .

5702A-03.TBL

Power Supply

Symbol	Parameter	Test Conditions	Min.	Typ.	Max.	Unit
SVR	Supply Voltage Rejection	0.5mV _{PP} on Pin V_{CC} 75 μ V _{PP} on Pin H1, H2 Measurement on Pin Chroma	15	20		dB

5702A-10.TBL

INPUT/OUTPUTS EQUIVALENT INTERNAL DIAGRAM

Pins : C1, C2

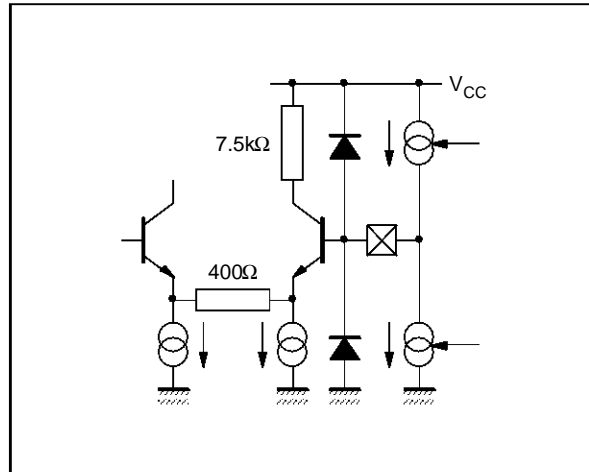

5702A-03.EPS

Pin : SW

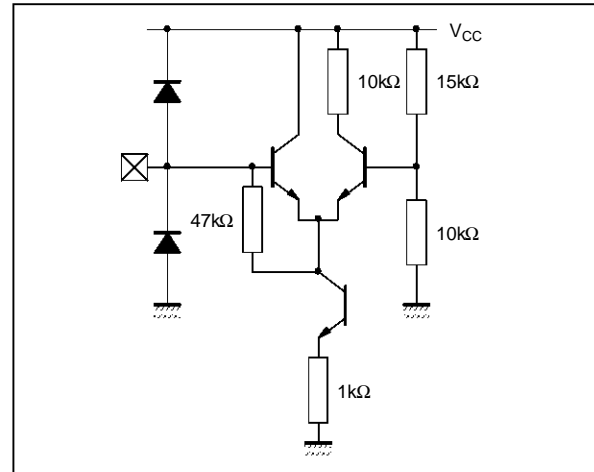

5702A-04.EPS

INPUT/OUTPUTS EQUIVALENT INTERNAL DIAGRAM (continued)

Pins : Chroma, Luma+, Luma-

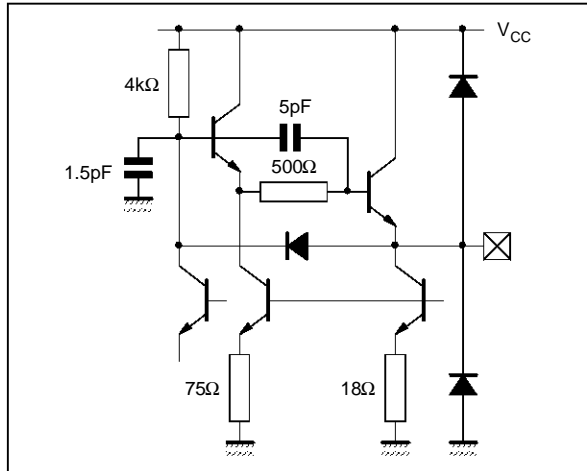

5702A-05.EPS

Pin : VMES

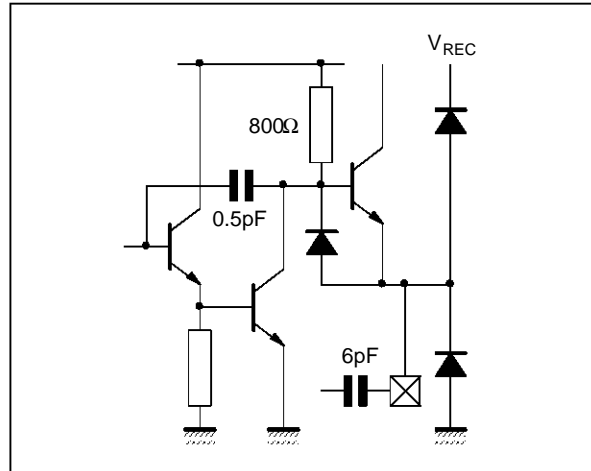

5702A-06.EPS

Pin : VIN

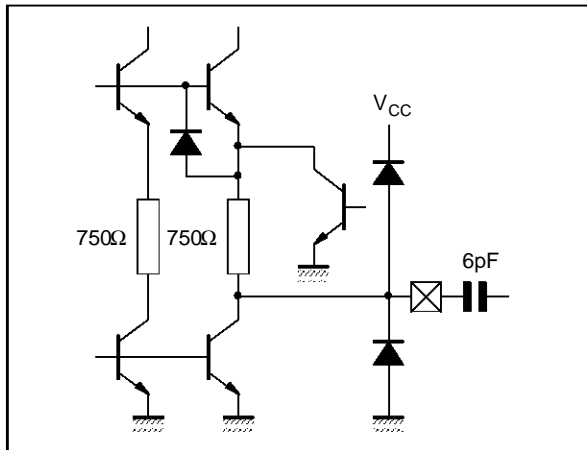

5702A-07.EPS

Pin : CAGC

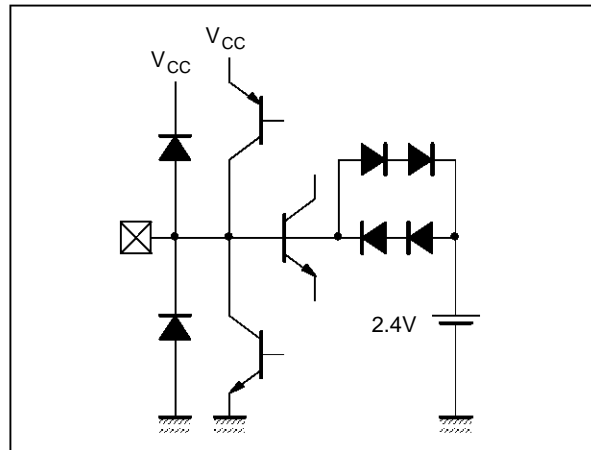

5702A-08.EPS

Pin : TRIV

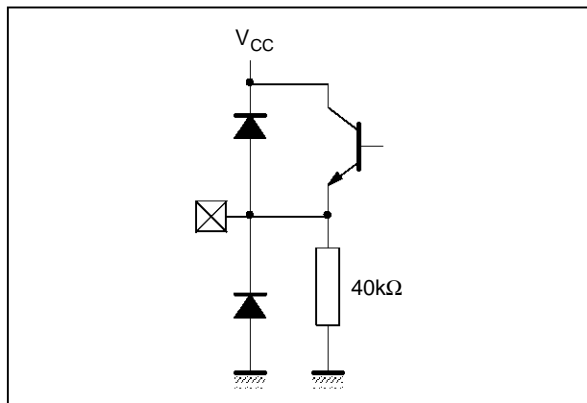

5702A-09.EPS

Pin : VCC1

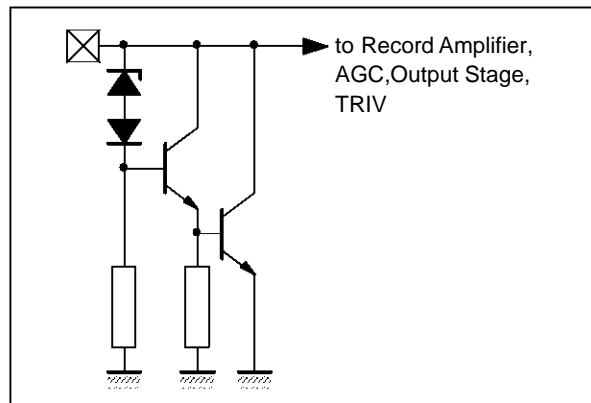

5702A-10.EPS

INPUT/OUTPUTS EQUIVALENT INTERNAL DIAGRAM (continued)

Pin : V_{REC}

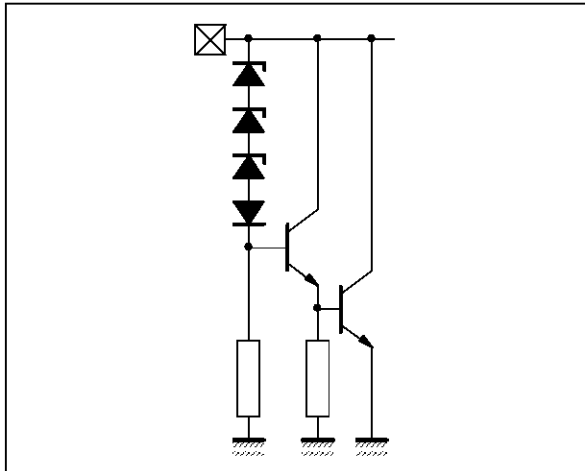

5702A-11.EPS

Pin : V_{CC2}

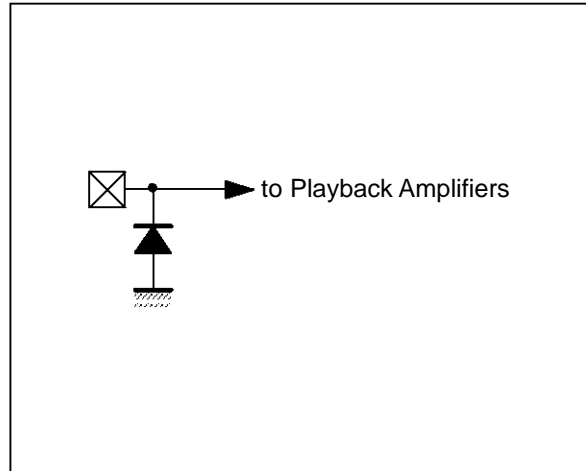

5702A-12.EPS

Pin : I_{OUT}

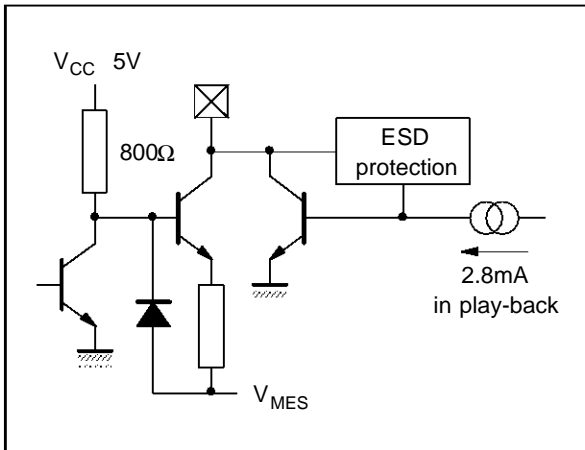

5702A-13.EPS

Pins : H₁, H₂, CCAS

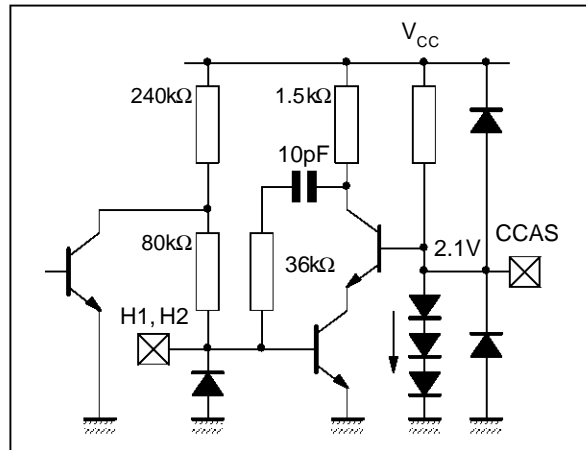

5702A-14.EPS

TYPICAL APPLICATION DIAGRAM

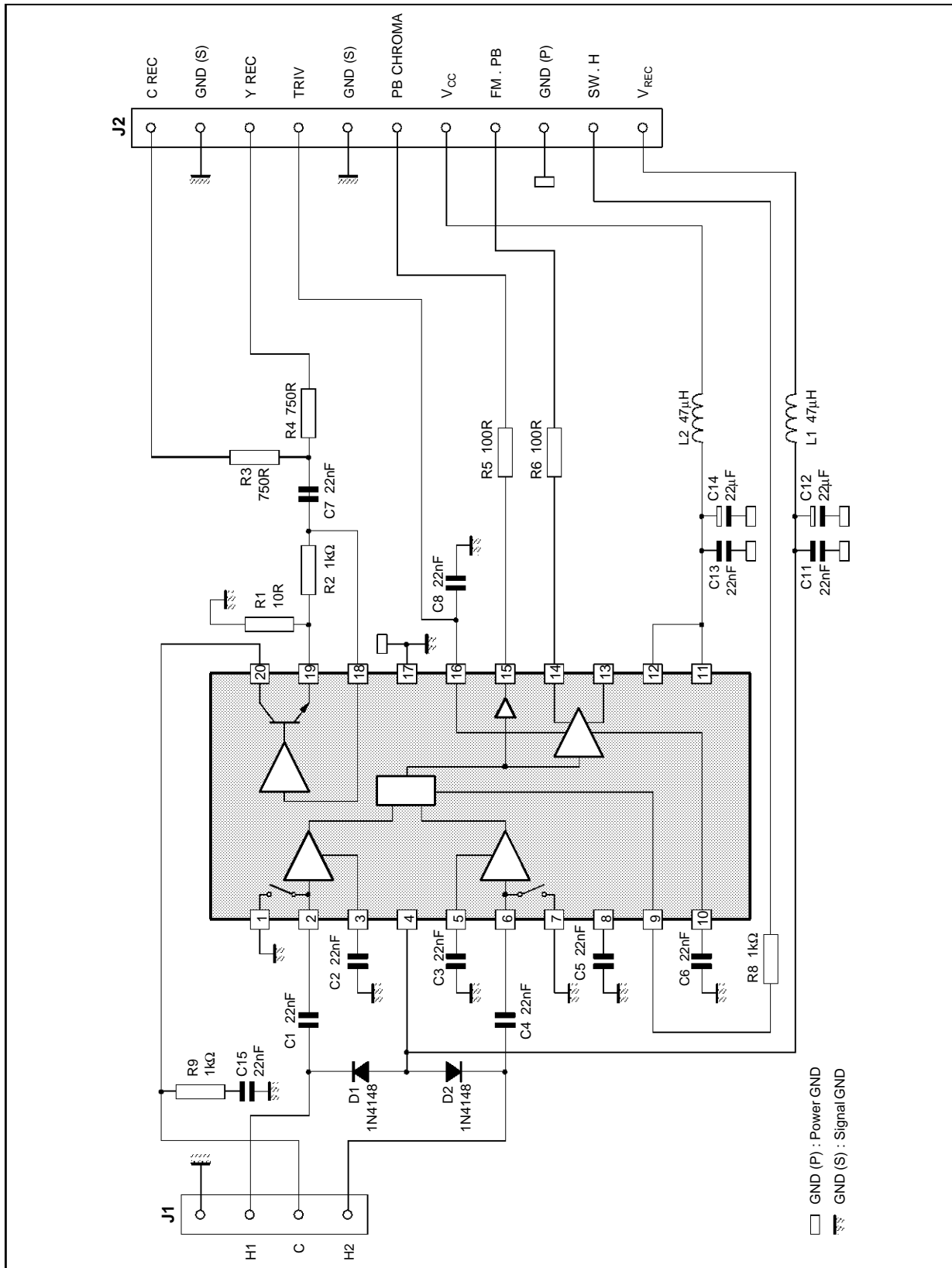

5702A-15.EPS

PACKAGE MECHANICAL DATA

20 PINS - PLASTIC DIP

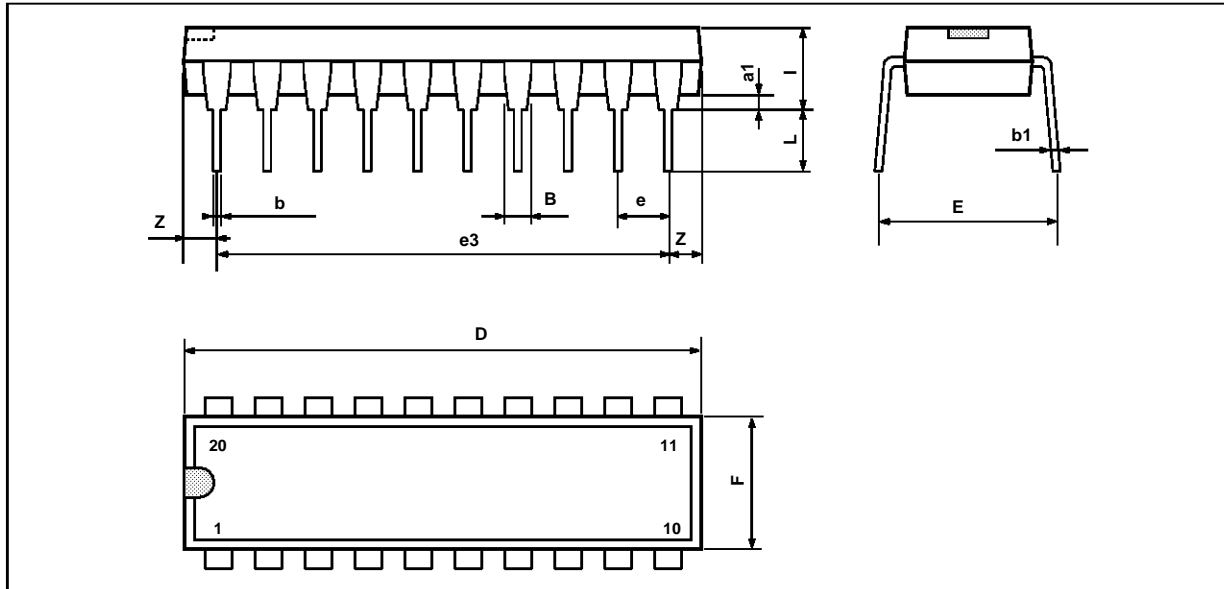

PM-DIP20.EPS

Dimensions	Millimeters			Inches		
	Min.	Typ.	Max.	Min.	Typ.	Max.
a1	0.254			0.010		
B	1.39		1.65	0.055		0.065
b		0.45			0.018	
b1		0.25			0.010	
D			25.4			1.000
E		8.5			0.335	
e		2.54			0.100	
e3		22.86			0.900	
F			7.1			0.280
i			3.93			0.155
L		3.3			0.130	
Z			1.34			0.053

DIP20.TBL

TEA5702A

PACKAGE MECHANICAL DATA 20 PINS - PLASTIC MICROPACKAGE

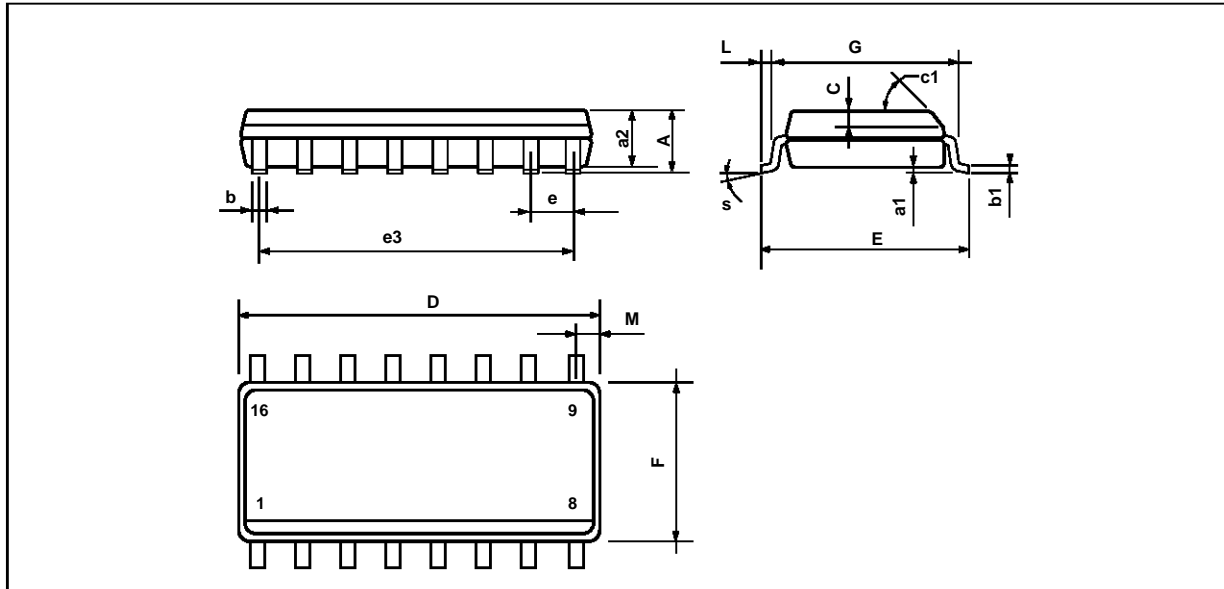

PM-SO20L.EPS

Dimensions	Millimeters			Inches		
	Min.	Typ.	Max.	Min.	Typ.	Max.
A			2.65			0.104
a1	0.1		0.2	0.004		0.008
a2			2.45			0.096
b	0.35		0.49	0.014		0.019
b1	0.23		0.32	0.009		0.013
C		0.5			0.020	
c1	45° (typ.)					
D	12.6		13.0	0.496		0.510
E	10		10.65	0.394		0.419
e		1.27			0.050	
e3		11.43			0.450	
F	7.4		7.6	0.291		0.300
L	0.5		1.27	0.020		0.050
M			0.75			0.030
S	8° (max.)					

SO20L.TBL

Information furnished is believed to be accurate and reliable. However, SGS-THOMSON Microelectronics assumes no responsibility for the consequences of use of such information nor for any infringement of patents or other rights of third parties which may result from its use. No licence is granted by implication or otherwise under any patent or patent rights of SGS-THOMSON Microelectronics. Specifications mentioned in this publication are subject to change without notice. This publication supersedes and replaces all information previously supplied. SGS-THOMSON Microelectronics products are not authorized for use as critical components in life support devices or systems without express written approval of SGS-THOMSON Microelectronics.

© 1994 SGS-THOMSON Microelectronics - All Rights Reserved

Purchase of I²C Components of SGS-THOMSON Microelectronics, conveys a license under the Philips I²C Patent. Rights to use these components in a I²C system, is granted provided that the system conforms to the I²C Standard Specifications as defined by Philips.

SGS-THOMSON Microelectronics GROUP OF COMPANIES

Australia - Brazil - China - France - Germany - Hong Kong - Italy - Japan - Korea - Malaysia - Malta - Morocco
The Netherlands - Singapore - Spain - Sweden - Switzerland - Taiwan - Thailand - United Kingdom - U.S.A.