

BUS-CONTROLLED VIDEO MATRIX SWITCH

- 15MHz BANDWIDTH
- 8 INPUTS (CVBS, RGB, MAC, chroma...)
- 6 OUTPUTS
- POSSIBILITY OF MAC OR CHROMA SIGNAL FOR EACH INPUT BY SWITCHING-OFF THE CLAMP WITH AN EXTERNAL RESISTOR BRIDGE
- BUS CONTROLLED
- 6.5dB GAIN BETWEEN ANY INPUT AND OUTPUT
- - 50dB CROSSTALK AT 5MHz
- FULLY PROTECTED AGAINST ESD

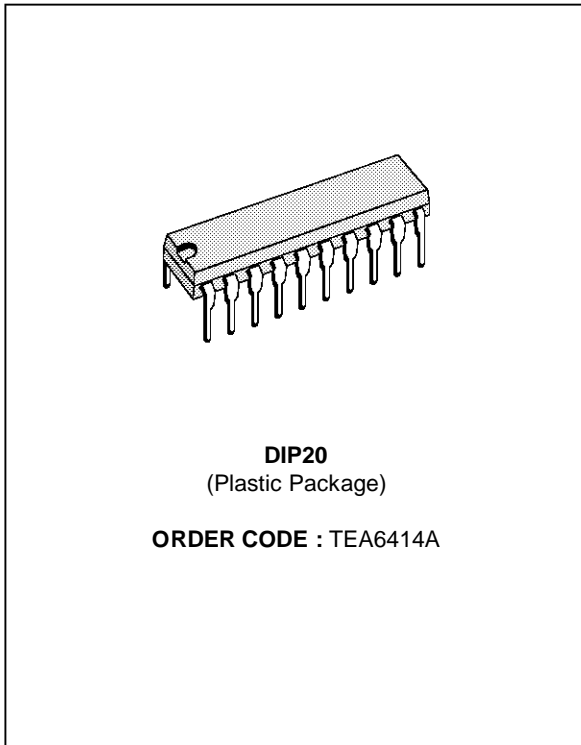

DESCRIPTION

The main function of the TEA6414A is to switch 8 video input sources on the 6 outputs. Each output can be switched to only one of the inputs whereas any same input may be connected to several outputs. All the switching possibilities are changed through the 3-Wire Bus (THOMSON BUS).

PIN CONNECTIONS

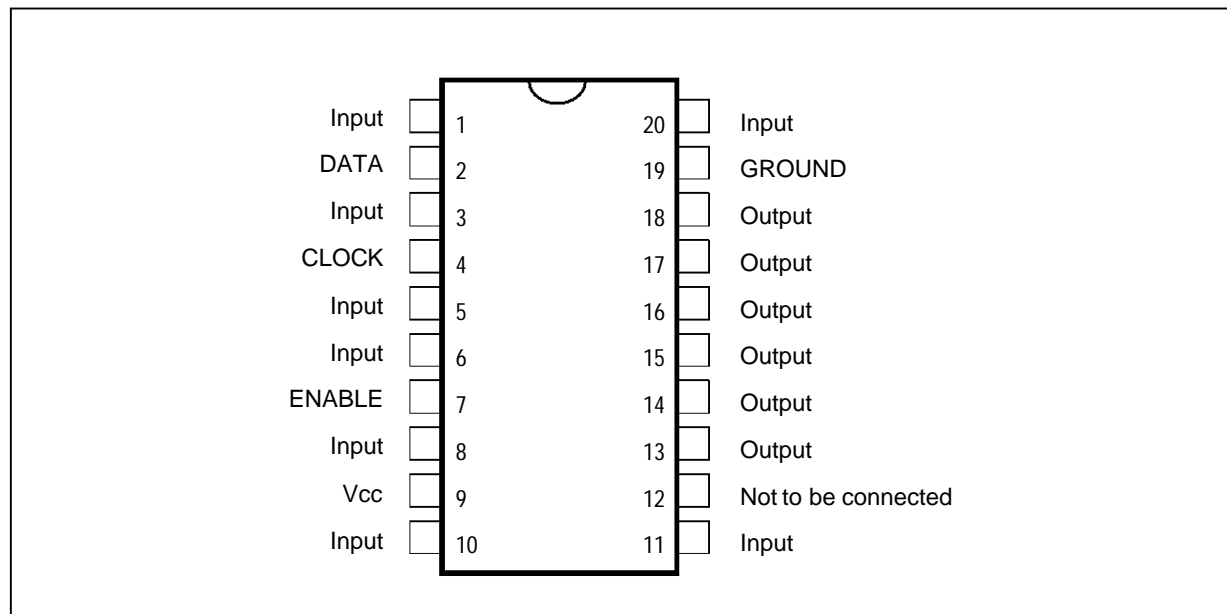

6414A-01.EPS

BLOCK DIAGRAM

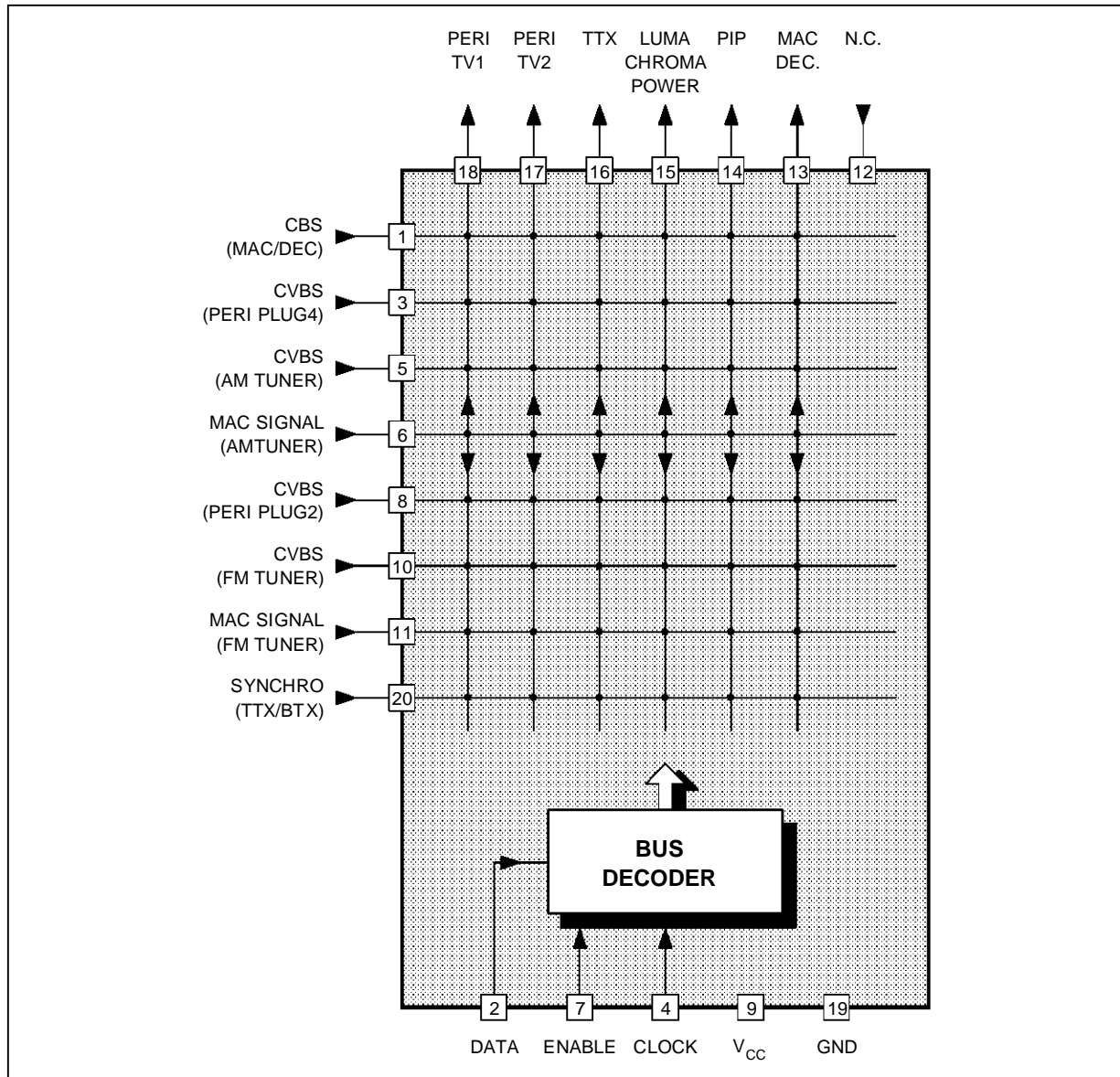

6414A-02.EPS

ABSOLUTE MAXIMUM RATINGS

Symbol	Parameter	Value	Unit
V _{CC}	Supply Voltage (pin 9)	13	V
T _A	Operating Ambient Temperature Range	0 to +70	°C
T _{stg}	Storage Temperature Range	-20 to +150	°C

6414A-01.TBL

THERMAL DATA

Symbol	Parameter	Value	Unit
R _{th(j-a)}	Junction-Ambient Thermal Resistance	80	°C/W

6414A-02.TBL

ELECTRICAL CHARACTERISTICS

$T_A = 25^{\circ}\text{C}$, $V_{CC} = 10\text{V}$, $R_{LOAD} = 10\text{k}\Omega$, $C_{LOAD} = 3\text{pF}$ (unless otherwise specified)

Symbol	Parameter	Min.	Typ.	Max.	Unit
V_{CC}	Supply Voltage (pin 9)	7	10	11	V
I_{CC}	Power Supply Current (without load on outputs ; $V_{CC}=10\text{V}$)	20	30	40	mA

INPUTS

	Maximum Signal Amplitude (CVBS signal)	2			V_{PP}
	Input Current (per output connected, input voltage = $5V_{DC}$) (this current is X6 when all outputs are connected on the input)		1	3	μA
	DC Level	3.3	3.6	3.9	V
	DC Level Shift (temperature from 0 to 70°C)		5	100	mV

OUTPUTS ($V_{IN} = 1V_{PP}$ for all dynamic tests) Pins 13-14-15-16-17-18

	Dynamic	4.5	5.5		V_{PP}
	Output Impedance		25	50	Ω
	Gain	5.5	6.5	7.5	dB
	Bandwidth (-1dB attenuation)	7	10		MHz
	Bandwidth (-3dB attenuation)		15		MHz
	Crosstalk ($f = 5\text{MHz}$)		-50		dB
	DC level	2.4	2.7	3	V

6414A-03.TBL

GENERAL DESCRIPTION

The main function of the IC is to switch 8 video input sources on 6 outputs.

Each output can be switched on only one of each input. On each input an alignment of the lowest level of the signal is made (bottom of synch. top for CVBS or black level for RGB signals).

Each nominal gain between any input and output is 6.5dB. For D2MAC or Chroma signal the alignment is switched off by forcing, with an external resistor bridge, $5V_{DC}$ on the input.

Each input can be used as a normal input or as a

MAC or Chroma input (with external resistor bridge).

All the switching possibilities are changed through the BUS.

Driving 75Ω load needs an external transistor.

It is possible to have the same input connected to several outputs.

The starting configuration (power supply from 0 to 10V) is undetermined. In this case, 6 words of 8 bits are necessary to determine one configuration. In other case, one word of 8 bits is necessary to determine one configuration.

BUS SELECTIONS (THOMSON BUS)

ADDRESS MSB	DATA LSB	Selected Output	
00000	XXX	Pin 18	Output is selected by address bits
00100	XXX	Pin 14	
00010	XXX	Pin 16	
00110	---	Not used	
00001	XXX	Pin 17	
00101	XXX	Pin 13	
00011	XXX	Pin 15	
00111	---	Not used	
		Selected Input	
00XXX	000	Pin 5	Input is selected by data bits
00XXX	100	Pin 8	
00XXX	010	Pin 3	
00XXX	110	Pin 20	
00XXX	001	Pin 6	
00XXX	101	Pin 10	
00XXX	011	Pin 1	
00XXX	111	Pin 11	

6414A-04.TBL

Example : 00100 101 connects pin 10 (input) to pin 14 (output) (equals 25 hex.).

IN / OUT PIN CONFIGURATION

Figure 1 : Input Configuration

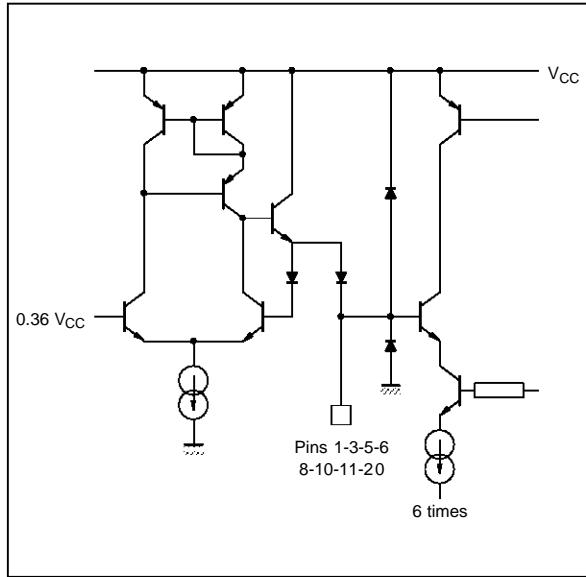

Figure 2 : Output Configuration

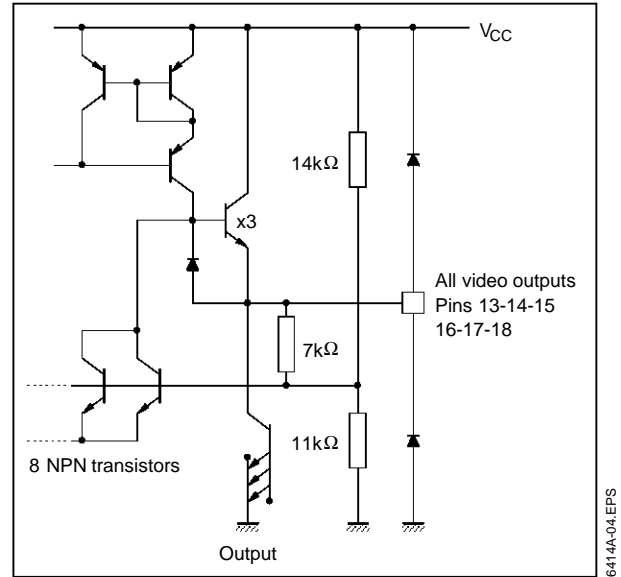

Figure 3 : Bus I/O Configuration

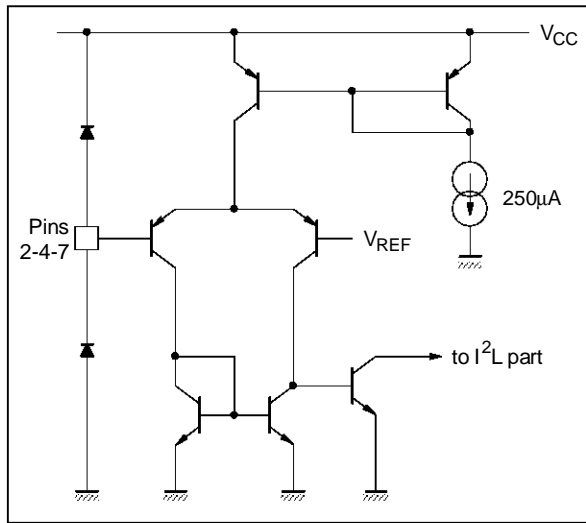
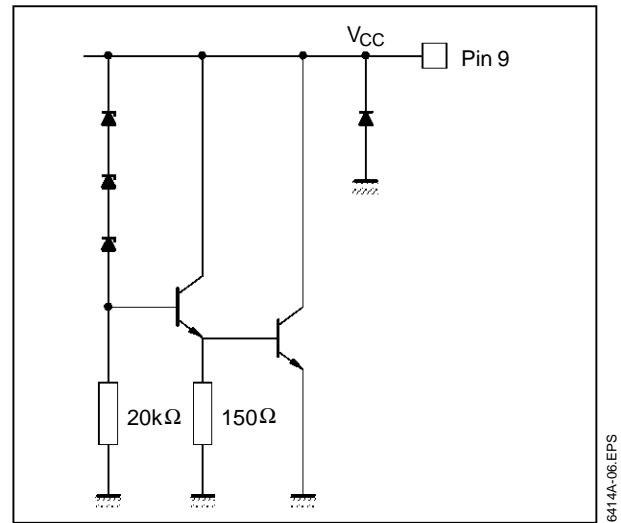

Figure 4 : V_{CC} Pin Configuration



SPECIFICATION FOR THE THOMSON BIDIRECTIONAL DATA BUS

The bidirectional data bus has three lines (DATA, CLOCK, ENABLE) and operates serially. Transmission on the DATALINE is effected bidirectionally,

whilst the ENABLE- and CLOCKLINES are driven only by the microprocessor. It is possible to select several ICs from the µP via the THOMSON BUS.

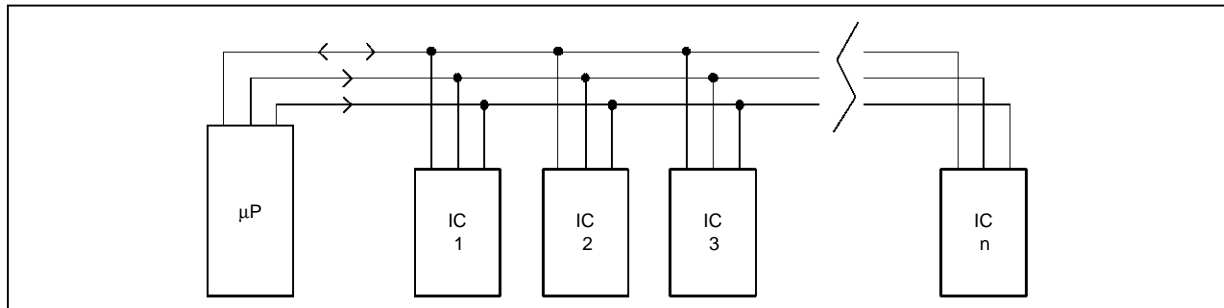

6414A-07.EPS

The identification or address of each particular IC is achieved by the length of the word (number of clock pulses), and each IC responds with its own particular word length. The address length is determined only while ENABLE is low, by counting the clock pulses. The rising edge of the ENABLE signal indicates the end of the address sequence.

Normally, there are several locations within the same chip, which must be selected individually, the datastream may, therefore be split into subaddress and data. In the case where an IC is not using the complete specified subaddress range it is possible to employ the unused subaddress range with a second or third IC with the same word length. The bitnumber of the subaddress is flexible.

The reply word length from any of the ICs to the μP is also flexible. This bidirectional transmission is possible from the last addressed IC after the posi-

tive going edge of the ENABLE signal if the ENABLE signal remains high and the CLOCK impulses are present on the line. The μP in effect clocks out the data from the chip. When an IC is able to send information in the bidirectional way, the μP decides whether to take all information, to suppress completely the information or to stop the transfer after any bit.

This reply word, synchronized to the clock from μP , is sent only once. Should a subsequent clock impulse be present on the clock line, it will switch the IC in question to high impedance.

The register, from which the bidirectional information comes, is addressed with the IC address. When more than one bidirectional register exists, the selection is made by the previously selected subaddress.

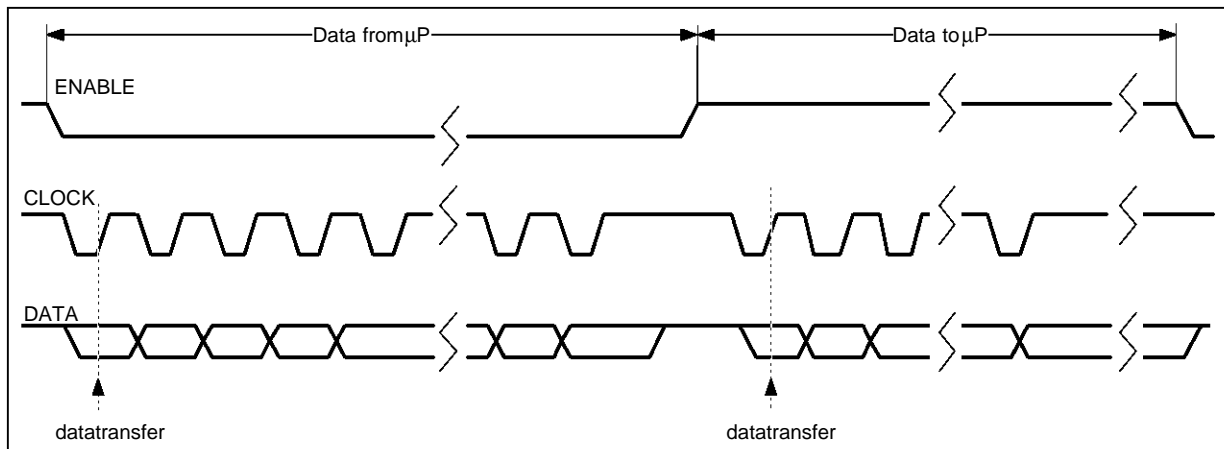

6414A-08.EPS

TIMING DIAGRAMS

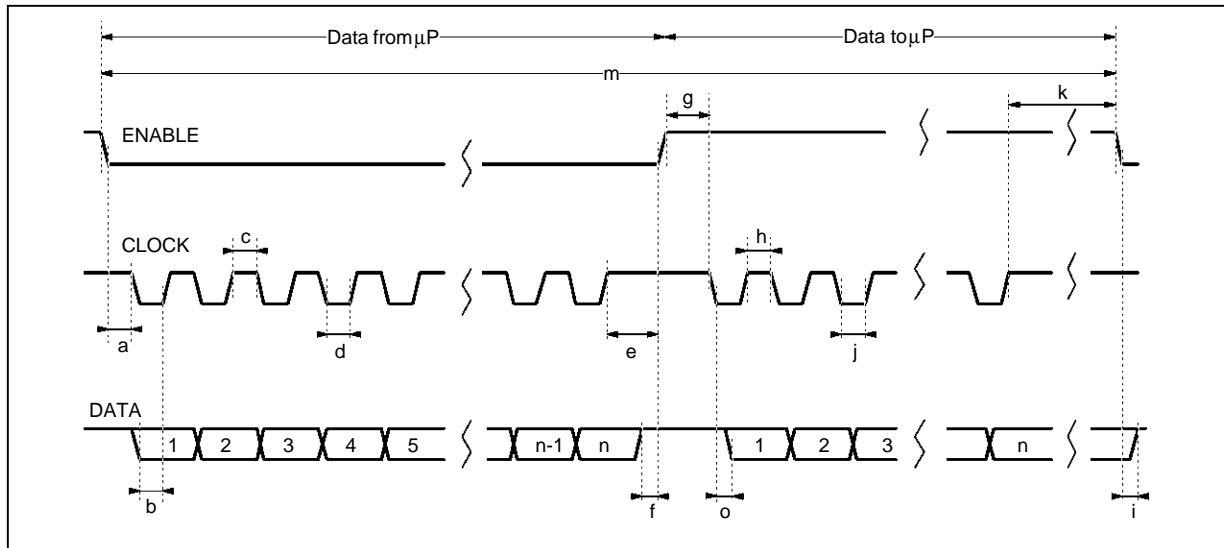

6414A-09.EPS

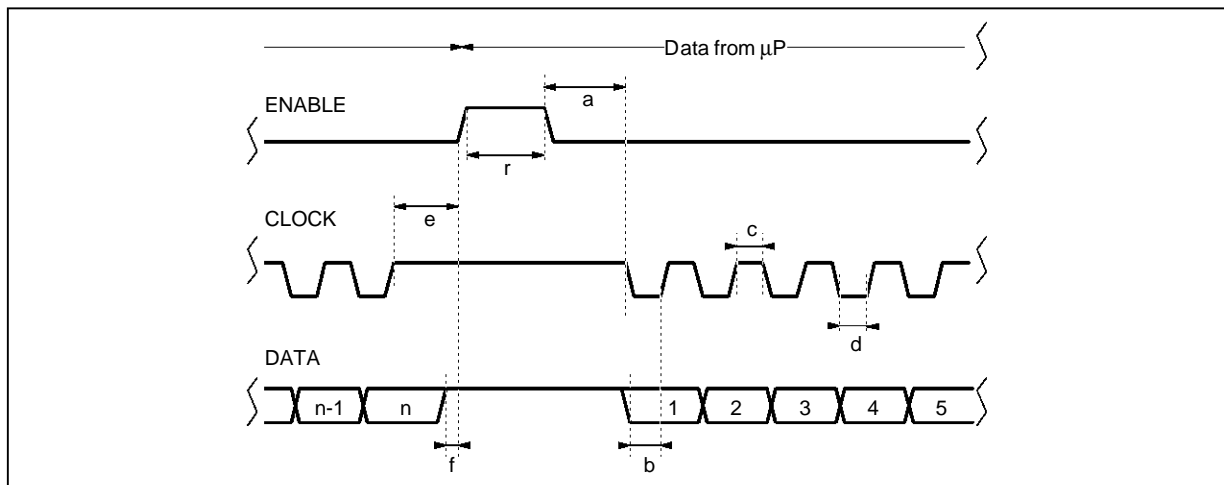

6414A-10.EPS

TIMING FOR THOMSON BUS

Parameter	Min.	Typ.	Max.	Unit
a	1			μs
b	1			μs
c	1			μs
d	1			μs
e	2			μs
f	1			μs
r	2			μs

6414A-05.TBL

BUS INPUTS (pin 2, 4 and 7)

Symbol	Parameter	Min.	Typ.	Max.	Unit
	High Level	3.5			V
	Low Level			1	V
	Input Current	-35	-13	0	μA
		<ul style="list-style-type: none"> ● 0.4V < V_{IN} < 1V ● V_{IN} > 3.5V 		2	

6414A-06.TBL

TYPICAL APPLICATION

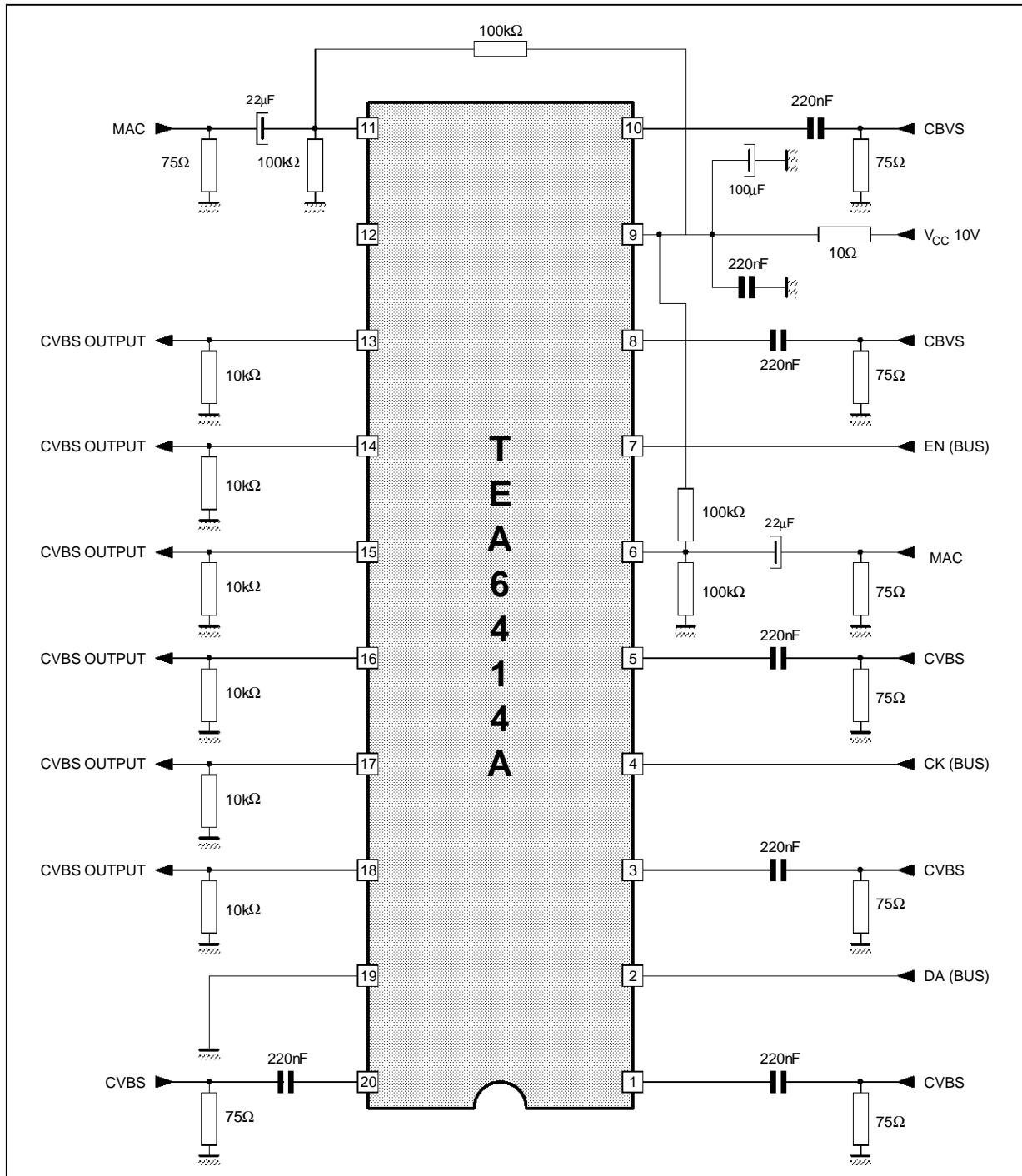

6414A-11.EPS

CROSSTALK IMPROVEMENT

1 - When any input is not used, it must be bypassed to ground through a 220nF capacitor.

2 - An important improvement can be achieved considering the input crosstalk by means of the application (refer to technical note).

OTHER APPLICATION DIAGRAM EXAMPLE

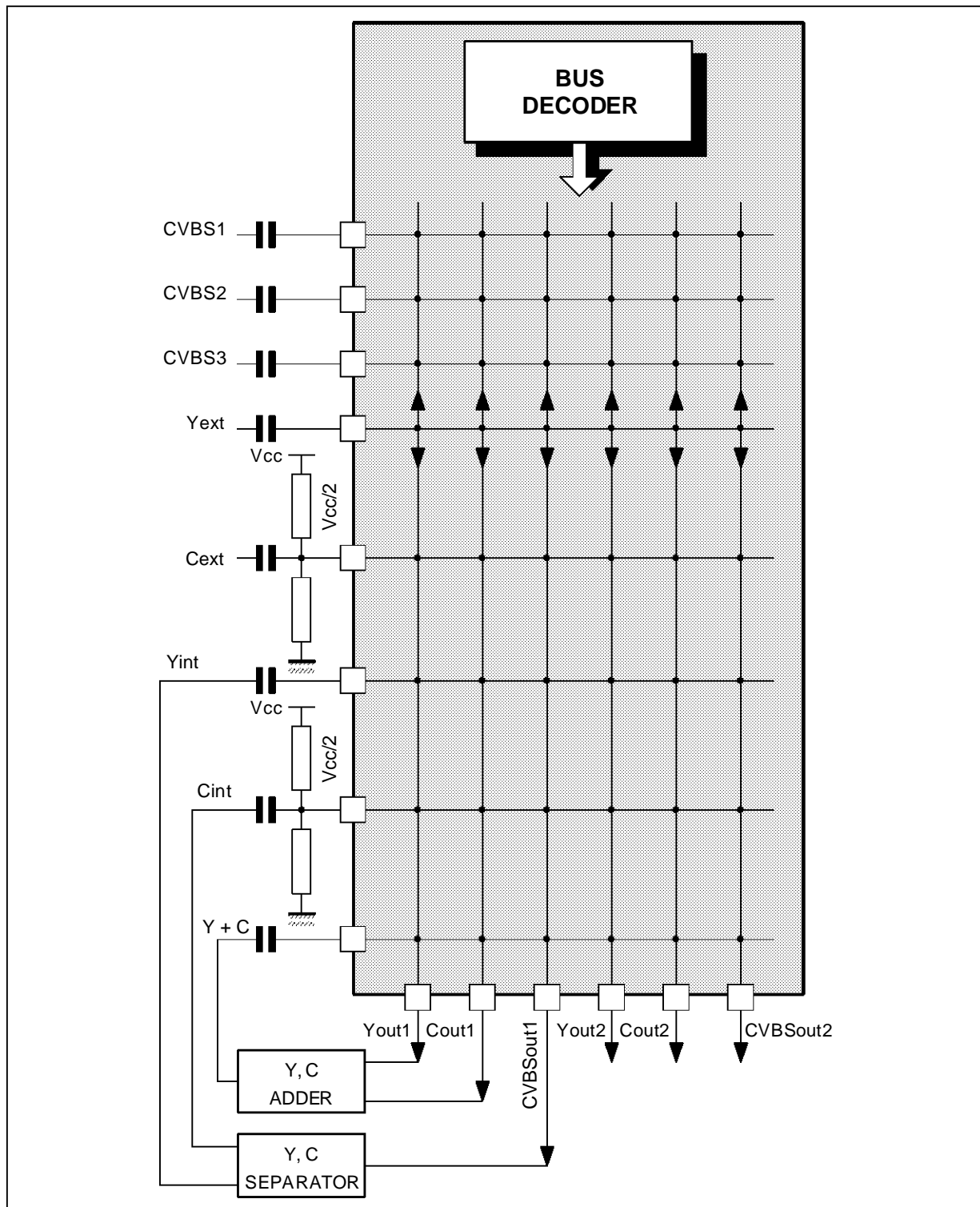

6414A-12.EPS

PACKAGE MECHANICAL DATA

20 PINS – PLASTIC DIP

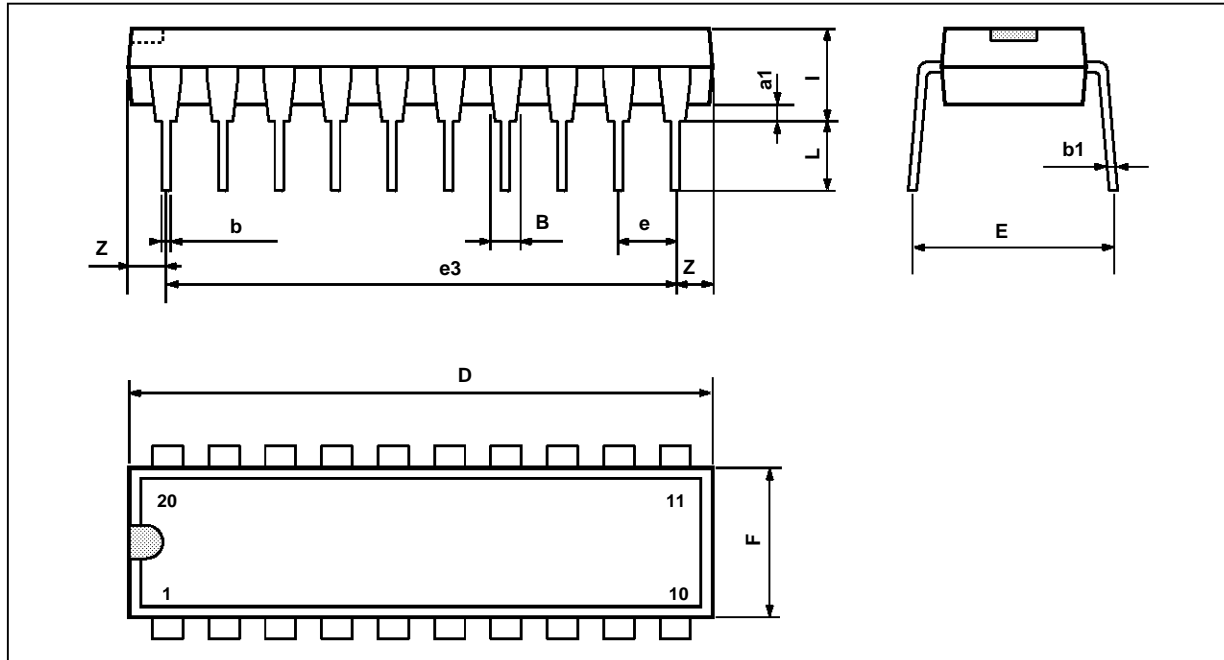

PM-DIP20.EPS

Dimensions	Millimeters			Inches		
	Min.	Typ.	Max.	Min.	Typ.	Max.
a1	0.254			0.010		
B	1.39		1.65	0.055		0.065
b		0.45			0.018	
b1		0.25			0.010	
D			25.4			1.000
E		8.5			0.335	
e		2.54			0.100	
e3		22.86			0.900	
F			7.1			0.280
i			3.93			0.155
L		3.3			0.130	
Z			1.34			0.053

DIP20.TEL

Information furnished is believed to be accurate and reliable. However, SGS-THOMSON Microelectronics assumes no responsibility for the consequences of use of such information nor for any infringement of patents or other rights of third parties which may result from its use. No licence is granted by implication or otherwise under any patent or patent rights of SGS-THOMSON Microelectronics. Specifications mentioned in this publication are subject to change without notice. This publication supersedes and replaces all information previously supplied. SGS-THOMSON Microelectronics products are not authorized for use as critical components in life support devices or systems without express written approval of SGS-THOMSON Microelectronics.

© 1994 SGS-THOMSON Microelectronics - All Rights Reserved

Purchase of I²C Components of SGS-THOMSON Microelectronics, conveys a license under the Philips I²C Patent. Rights to use these components in a I²C system, is granted provided that the system conforms to the I²C Standard Specifications as defined by Philips.

SGS-THOMSON Microelectronics GROUP OF COMPANIES

Australia - Brazil - China - France - Germany - Hong Kong - Italy - Japan - Korea - Malaysia - Malta - Morocco
The Netherlands - Singapore - Spain - Sweden - Switzerland - Taiwan - Thailand - United Kingdom - U.S.A.