

LOW-DROP VOLTAGE REGULATOR

- $V_O = 10V \pm 4\%$ ($I_O = 5mA$)
- $I_O = 5$ TO $500mA$
- $V_I - V_O = 0.6V$ ($I_O = 500mA$)
- V_I (surge) = $\pm 80V$
- THERMAL AND SHORT-CIRCUIT PROTECTION

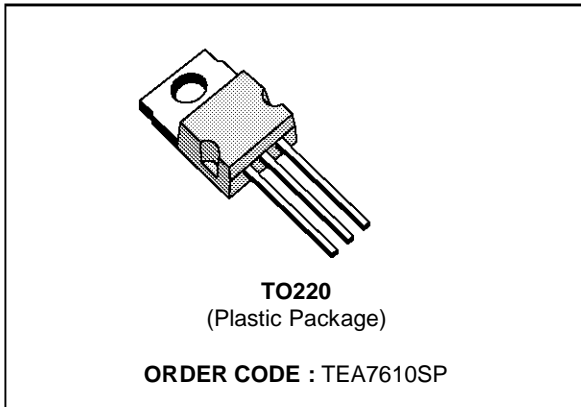

PIN CONNECTIONS

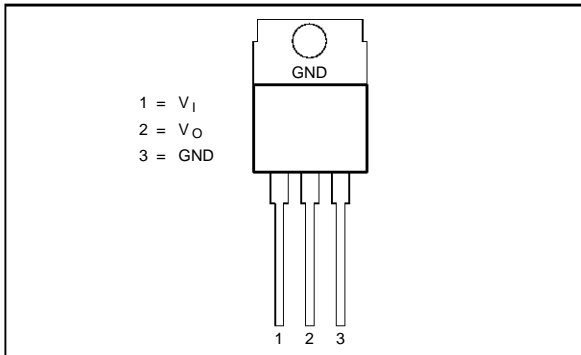

DESCRIPTION

TEA7610 is a low-drop regulator well suited to supplying stabilized voltage to μ Ps in harsh industrial environment.

Special care was taken to keep :

- Lowest possible output capacitor ($1\mu F$).

BLOCK DIAGRAM

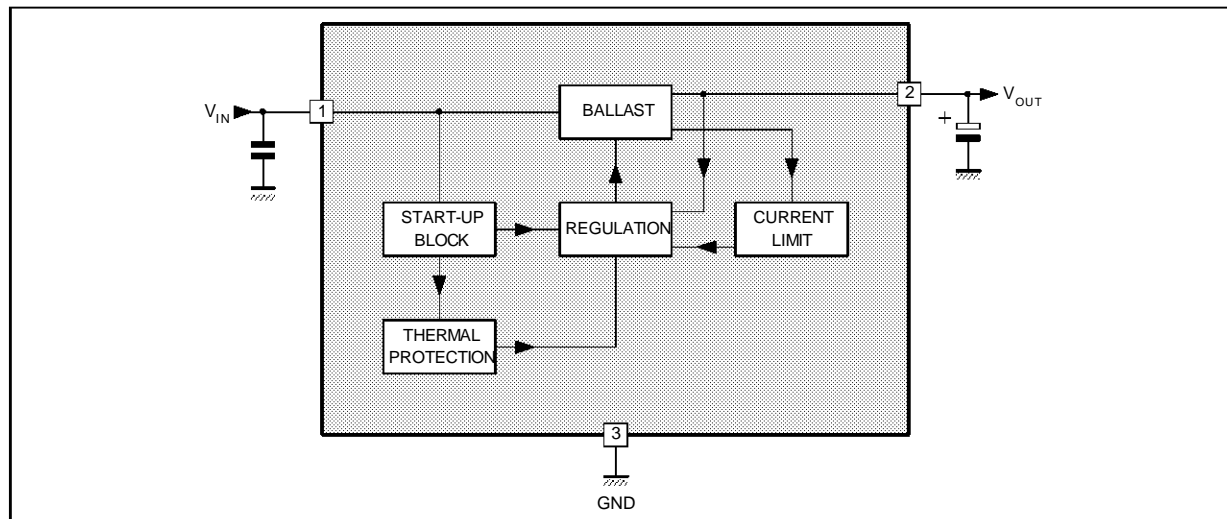

ABSOLUTE MAXIMUM RATINGS

Symbol	Parameter	Value	Unit
V_I	Input Voltage - Continuous - $\tau = 300$ ms	30	V
		80	V
$V_{I(R)}$	Reverse Input Voltage - Continuous - $\tau = 120$ ms	- 18	V
		- 80	V
T_J	Operating Junction Temperature	- 45, +150	°C
T_{stg}	Storage Temperature	- 55, +150	°C

7610-01.TBL

THERMAL DATA

Symbol	Parameter	Value	Unit
$R_{th(j-c)}$	Junction-case Thermal Resistance	Max. 3	°C/W
$R_{th(j-a)}$	Junction-ambient Thermal Resistance	Max. 70	°C/W

7610-02.TBL

ELECTRICAL OPERATING CHARACTERISTICS

$T_j = 25^\circ\text{C}$, $V_I = 14.4\text{V}$ (unless otherwise specified) Output Capacitor = $10\mu\text{F}$ (see note)

Symbol	Parameter	Min.	Typ.	Max.	Unit
V_O	Output Voltage ($I_O = 5$ to 500mA)	9.7	10	10.3	V
V_I	Input Supply Voltage (permanent)			28	V
I_{CC}	Current Consumption	$I_O = 0\text{mA}$	1.5	2	mA
		$I_O = 150\text{mA}$	10	20	mA
		$I_O = 500\text{mA}$	75	100	mA
K_{VI}	Line Regulation ($V_I = 11$ to 26V ; $I_O = 5\text{mA}$)		5	20	mV
K_{VO}	Load Regulation ($I_O = 5$ to 500mA)		40	80	mV
$V_I - V_O$	Drop-out Voltage	$I_O = 150\text{mA}$	0.18		V
		$I_O = 500\text{mA}$	0.4	0.6	V
SVR	Supply Voltage Rejection ($I_O = 350\text{mA}$, $f = 120\text{Hz}$, $C_O = 1\mu\text{F}$, $V_I = 12 \pm 5\text{V}$)		60		dB
I_{OS}	Short-circuit Output Current	0.5	0.7		A

7610-03.TBL

NOTE: Applications Hints

The output capacitor has a direct influence on output voltage stability. A $10\mu\text{F}$ capacitor will provide satisfactory results. There is no upper limit on this capacitor value.

If necessary, this value can be reduced down to $1\mu\text{F}$; however, in such case, it should be checked that output capacitor keeps sufficiently high capacitance and low equivalent series resistance in the whole temperature range.

Such low capacitor value is not recommended either, if output current is to switch abruptly from very high to very low values (for instance, 400mA to $< 1\text{mA}$).

ELECTRICAL OPERATING CHARACTERISTICS

$T_j = -45^\circ\text{C}$ to $+125^\circ\text{C}$, $V_I = 14.4\text{V}$ (unless otherwise specified) Output Capacitor = $10\mu\text{F}$

Symbol	Parameter	Min.	Typ.	Max.	Unit
V_O	Output Voltage ($I_O = 5$ to 500mA)	9.6	10	10.4	V
$\frac{dV_O}{dt}$	Output Voltage Drift $T_j = -45$ to $+25^\circ\text{C}$ $T_j = +25$ to $+125^\circ\text{C}$	- 1 - 1.2			mV/°C
I_{CC}	Current Consumption	$I_O = 0\text{mA}$		2.5	mA
		$I_O = 150\text{mA}$		25	mA
		$I_O = 500\text{mA}$		120	mA
K_{VI}	Line Regulation ($V_I = 11$ to 26V , $I_O = 5\text{mA}$)			30	mV
K_{VO}	Load Regulation ($I_O = 5$ to 500mA)			100	mV
$V_I - V_O$	Drop-out Voltage	$I_O = 150\text{mA}$	0.2		V
		$I_O = 500\text{mA}$		0.8	V
I_{OS}	Short-circuit Output Current	0.4			A
I_{OM}	Maximum Output Current	0.5			A

7610-04.TBL

TYPICAL DIAGRAM

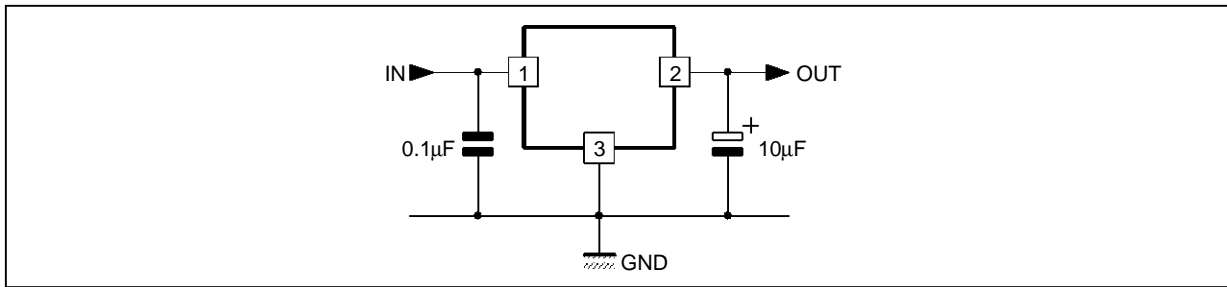

7610-03.EPS

PACKAGE MECHANICAL DATA

3 PINS - PLASTIC TO220

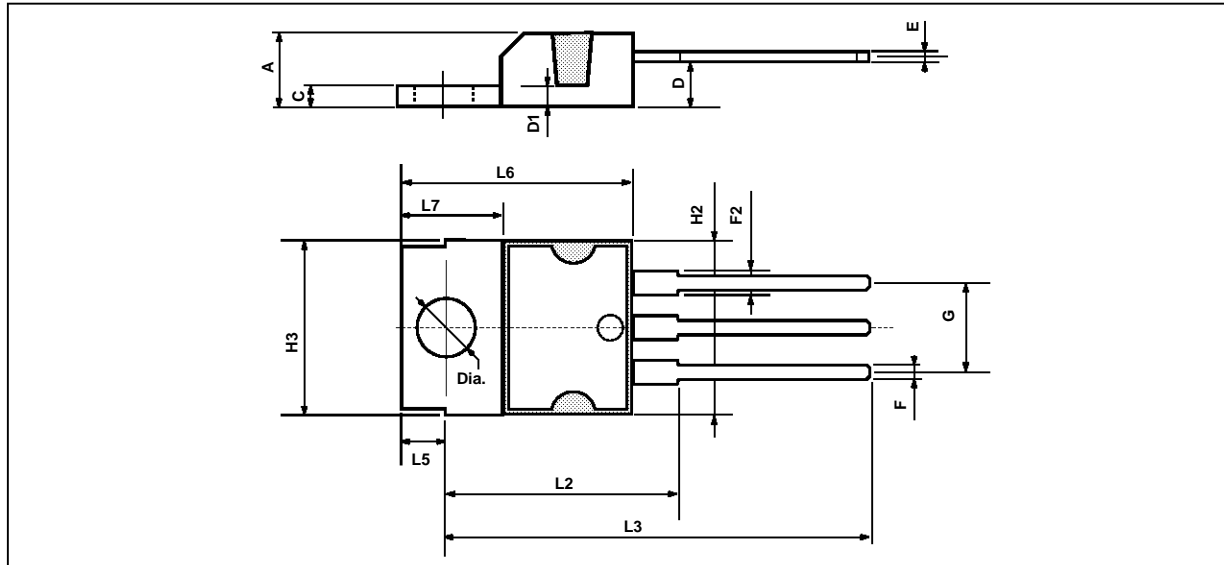

PM-T0220.EPS

Dimensions	Millimeters			Inches		
	Min.	Typ.	Max.	Min.	Typ.	Max.
A			4.8			0.189
C			1.37			0.054
D	2.4		2.8	0.094		0.110
D1	1.2		1.35	0.047		0.053
E	0.35		0.55	0.014		0.022
F	0.8		1.05	0.031		0.041
F2	1.15		1.4	0.045		0.055
G	4.95	5.08	5.21	0.195	0.200	0.205
H2			10.4			0.409
H3	10.05		10.4	0.396		0.409
L2		16.2			0.638	
L3	26.3	26.7	27.1	1.035	1.051	1.067
L5	2.6		3	0.102		0.118
L6	15.1		15.8	0.594		0.622
L7	6		6.6	0.236		0.260
Dia.	3.65		3.85	0.144		0.152

TO220.TBL

Information furnished is believed to be accurate and reliable. However, SGS-THOMSON Microelectronics assumes no responsibility for the consequences of use of such information nor for any infringement of patents or other rights of third parties which may result from its use. No licence is granted by implication or otherwise under any patent or patent rights of SGS-THOMSON Microelectronics. Specifications mentioned in this publication are subject to change without notice. This publication supersedes and replaces all information previously supplied. SGS-THOMSON Microelectronics products are not authorized for use as critical components in life support devices or systems without express written approval of SGS-THOMSON Microelectronics.

© 1994 SGS-THOMSON Microelectronics - All Rights Reserved

Purchase of I²C Components of SGS-THOMSON Microelectronics, conveys a license under the Philips I²C Patent. Rights to use these components in a I²C system, is granted provided that the system conforms to the I²C Standard Specifications as defined by Philips.

SGS-THOMSON Microelectronics GROUP OF COMPANIES

Australia - Brazil - China - France - Germany - Hong Kong - Italy - Japan - Korea - Malaysia - Malta - Morocco
The Netherlands - Singapore - Spain - Sweden - Switzerland - Taiwan - Thailand - United Kingdom - U.S.A.