

**STEPPER MOTOR DRIVER**

- HALF AND FULL-STEP MODES
- BIPOLAR DRIVE OF STEPPER MOTOR FOR MAXIMUM MOTOR PERFORMANCE
- BUILT-IN PROTECTION DIODES
- WIDE RANGE OF CURRENT CONTROL : 5 TO 1500 mA
- WIDE VOLTAGE RANGE : 10 TO 50 V
- DESIGNED FOR UNSTABILIZED MOTOR SUPPLY VOLTAGE
- CURRENT LEVELS CAN BE SELECTED IN STEPS OR VARIED CONTINUOUSLY
- THERMAL OVERLOAD PROTECTION
- ALARM OUTPUT (TEF3718SP) OR PRE-ALARM OUTPUT (TEF3718SSP)

**DESCRIPTION**

The TEF3718 and TEF3718S are bipolar monolithic integrated circuits intended to control and drive the current in one winding of a bipolar stepper motor. The circuits consist of an LS-TTL - compatible logic input, a current sensor, a monostable and an output stage with built-in protection diodes. Two TEF3718 or TEF3718S and a few external components form a complete control and drive unit for LS-TTL or microprocessor controlled stepper motor systems.

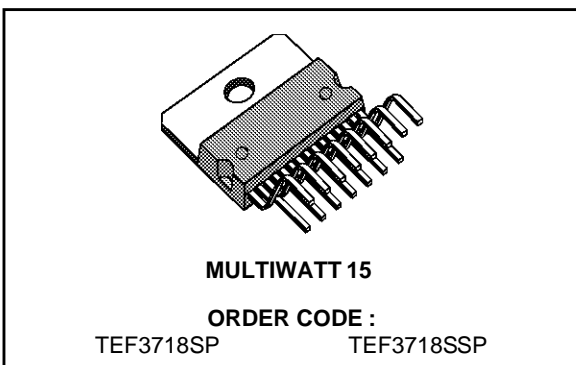
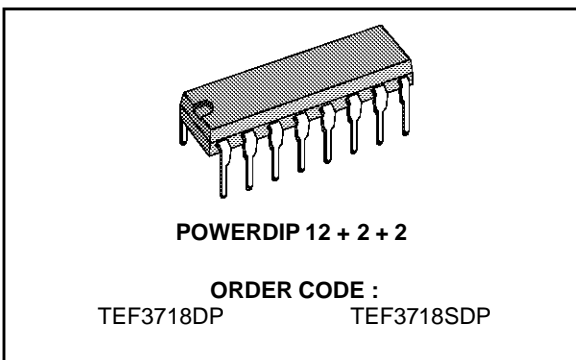

**PIN CONNECTON**

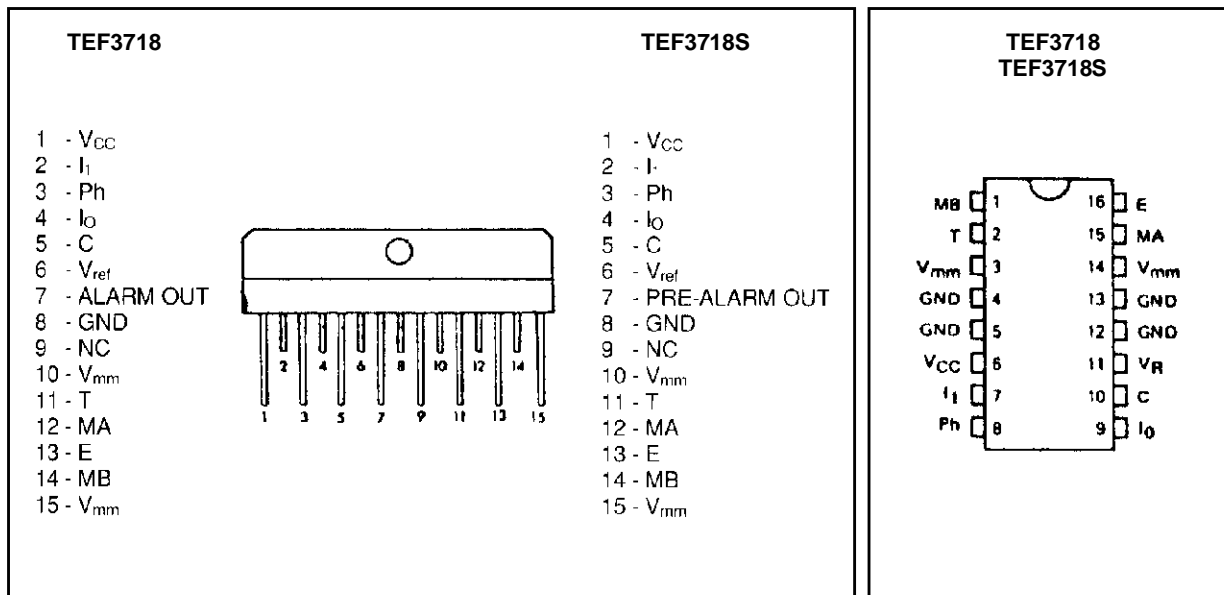

TEF3718-TEF3718S

BLOCK DIAGRAM (TEF3718)

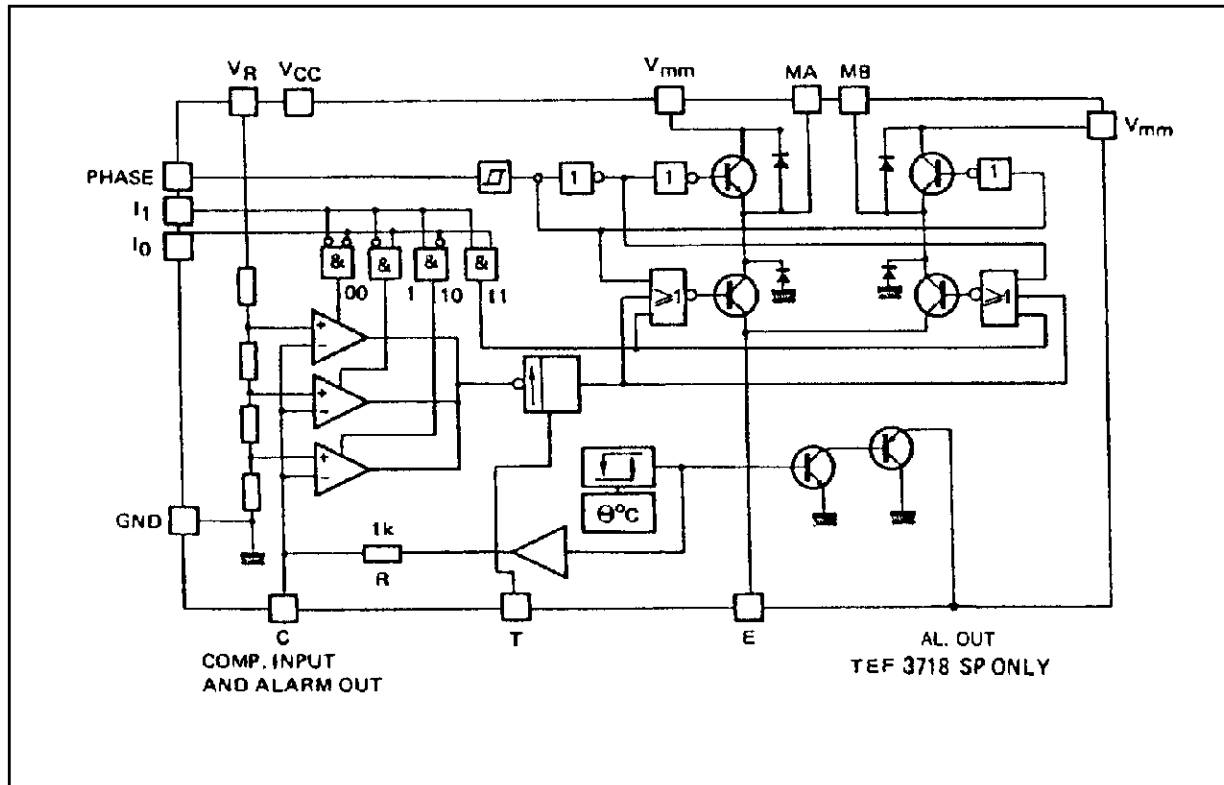

BLOCK DIAGRAM (TEF3718S)

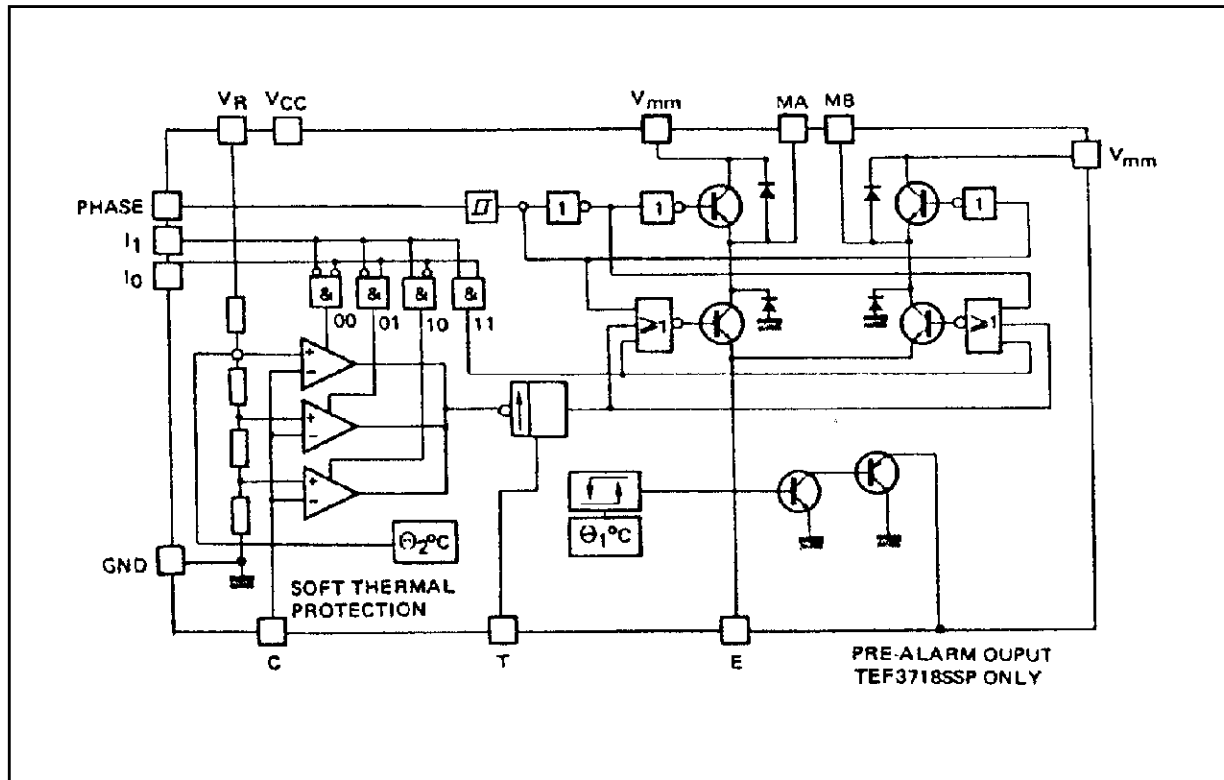

**ABSOLUTE MAXIMUM RATINGS**

Symbol	Parameter	Value	Unit
V <sub>CC</sub> V <sub>MM</sub>	Supply Voltage	7 50	V
V <sub>I</sub>	Input Voltage : Logic Inputs Analog Inputs Reference Input	6 V <sub>CC</sub> 15	V
I <sub>I</sub>	Input Current : Logic Inputs Analog Inputs	10 10	mA
I <sub>O</sub>	Output Current	± 1.5	A
T <sub>j</sub>	Junction Temperature	+ 150	°C
T <sub>oper</sub>	Operating Ambient Temperature Range	- 40 to + 85	°C
T <sub>stg</sub>	Storage Temperature Range	- 55 to 150	°C

**THERMAL CHARACTERISTICS**

Symbol	Parameter	Value	Unit
R <sub>th(j-c)</sub>	Maximum Junction-case Thermal Resistance POWERDIP MULTIW	11 3	°C/W
R <sub>th(j-a)</sub>	Maximum Junction-ambient Thermal Resistance POWERDIP MULTIW	45 (*) 40	°C/W

(\*) Soldered on a 35 µm thick 20 cm<sup>2</sup> PC board cooper area.

**RECOMMENDED OPERATING CONDITIONS**

Symbol	Parameter	Min.	Typ.	Max.	Unit
V <sub>CC</sub> V <sub>MM</sub>	Supply Voltage	4.75 10	5 -	5.25 45	V
I <sub>m</sub>	Output Current	0.020	-	1.2	A
T <sub>amb</sub>	Ambient Temperature	- 40	-	85	°C
t <sub>r</sub>	Rise Time Logic Inputs	-	-	2	µs
t <sub>f</sub>	Fall Time Logic Inputs	-	-	2	µs

## TEF3718-TEF3718S

### ELECTRICAL CHARACTERISTICS

$V_{CC} = 5\text{ V} \pm 5\%$ .  $V_{MM} = -10\text{ V}$  to  $+45\text{ V}$ .  $T_{amb} = -40\text{ }^{\circ}\text{C}$  to  $+25\text{ }^{\circ}\text{C}$  (Unless otherwise specified)

Symbol	Characteristics	Min.	Typ.	Max.	Unit
$I_{CC}$	Supply Current			25	mA
$V_{IH}$	High Level Input Voltage Logic Input	2			V
$V_{IL}$	Low Level Input Voltage Input			0.7	V
$I_{IH}$	High Level Input Current Logic Input ( $V_I = 2.4\text{ v}$ )			20	$\mu\text{A}$
$I_{IL}$	Low Level Input Current Logic Input ( $V_I = 0.4\text{ v}$ )	0.4			$\mu\text{A}$
$V_{CH}$ $V_{CM}$ $V_{CL}$	Comparator Treshold Voltage ( $V_R = +5\text{ V}$ ) $I_O = 0\ I_1 = 0$ $I_O = 1\ I_1 = 0$ $I_O = 0\ I_1 = 1$	390 230 65	420 250 80	440 270 90	mV
$I_{CO}$	Comparator Input Current	-20		20	$\mu\text{A}$
$I_{off}$	Output Leakage Current ( $I_O = 1, I_1 = 1$ )			100	$\mu\text{A}$
$V_{sat}$	Total Saturation Voltage Drop ( $I_m = 1\text{ A}$ )			2.9 3.3	V
					POWERDIP MULTIWATT
$P_{tot}$	Total Power Dissipation ( $I_m = 1\text{ A}$ , $f_s = 30\text{ kHz}$ )		3.1	3.6	W
$t_{off}$	Cutt off Time (see figures 1 and 2 $V_{mm} = +10\text{ V}$ , $V_{ton} \leq 5\ \mu\text{s}$ )	25	30	35	$\mu\text{s}$
$t_d$	Turn off Delay (see figures 1 and 2, $T_{amb} = +25\text{ }^{\circ}\text{C}$ $dV_C/dt \leq 50\text{ mV}/\mu\text{s}$ )		1.6		$\mu\text{s}$
$V_{sat}$	Alarm Output Saturation Voltage $I_O = 2\text{ mA}$		0.8		V
$I_{ref}$	Reference Input Current, $V_R = 5\text{ V}$		0.4	1	mA
$V_{sat}$	Source Diode Transistor Pair			1.35 1.75	mA
					MULTIWATT
	Saturation Voltage			1.25 1.55	
$V_f$	Diode Forward Voltage			1.5 1.7	
					POWERDIP
$I_{sub}$	Substrate Leakage Current			10	
	Sink Diode Transistor Pair			1.35 1.55	mA
					MULTIWATT
$V_{sat}$	Saturation Voltage			1.25 1.35	
$V_f$	Diode Forward Voltage			1.5 1.8	
					POWERDIP

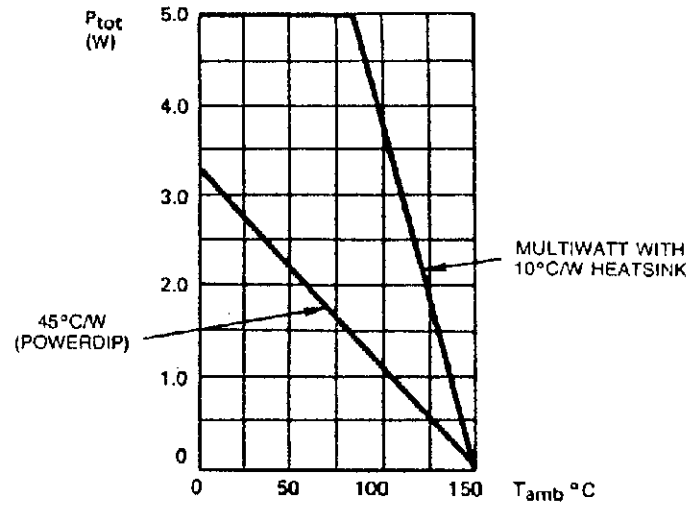
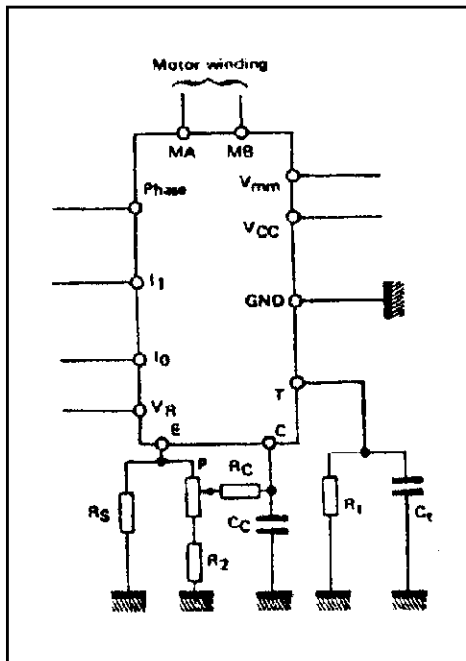
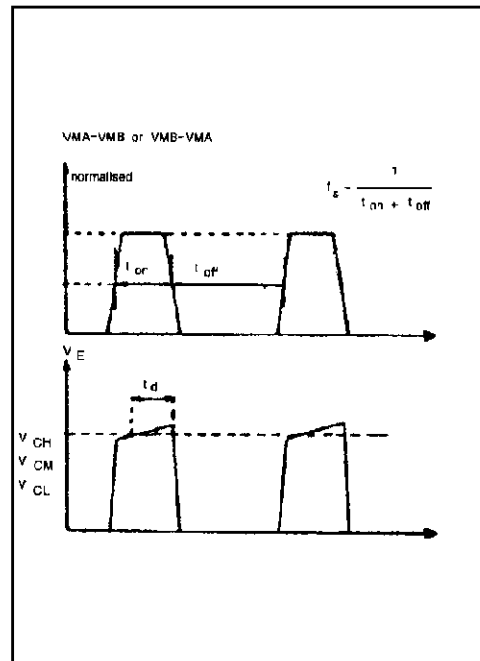

Figure 1.



$R_S = 1 \Omega$  inductance free  
 $R_C = 470 \Omega$   
 $C_C = 820 \text{ pF}$  ceramic  
 $R_T = 56 \text{ k}\Omega$   
 $C_T = 820 \text{ pF}$  ceramic  
 $P = 500 \Omega$   
 $R_2 = 1 \text{ K}$

Figure 2.



TEF3718-TEF3718S

MULTIWATT15 PACKAGE MECHANICAL DATA

DIM.	mm			inch		
	MIN.	TYP.	MAX.	MIN.	TYP.	MAX.
A			5			0.197
B			2.65			0.104
C			1.6			0.063
D		1			0.039	
E	0.49		0.55	0.019		0.022
F	0.66		0.75	0.026		0.030
G	1.02	1.27	1.52	0.040	0.050	0.060
G1	17.53	17.78	18.03	0.690	0.700	0.710
H1	19.6			0.772		
H2			20.2			0.795
L	21.9	22.2	22.5	0.862	0.874	0.886
L1	21.7	22.1	22.5	0.854	0.870	0.886
L2	17.65		18.1	0.695		0.713
L3	17.25	17.5	17.75	0.679	0.689	0.699
L4	10.3	10.7	10.9	0.406	0.421	0.429
L7	2.65		2.9	0.104		0.114
M	4.25	4.55	4.85	0.167	0.179	0.191
M1	4.63	5.08	5.53	0.182	0.200	0.218
S	1.9		2.6	0.075		0.102
S1	1.9		2.6	0.075		0.102
Dia1	3.65		3.85	0.144		0.152

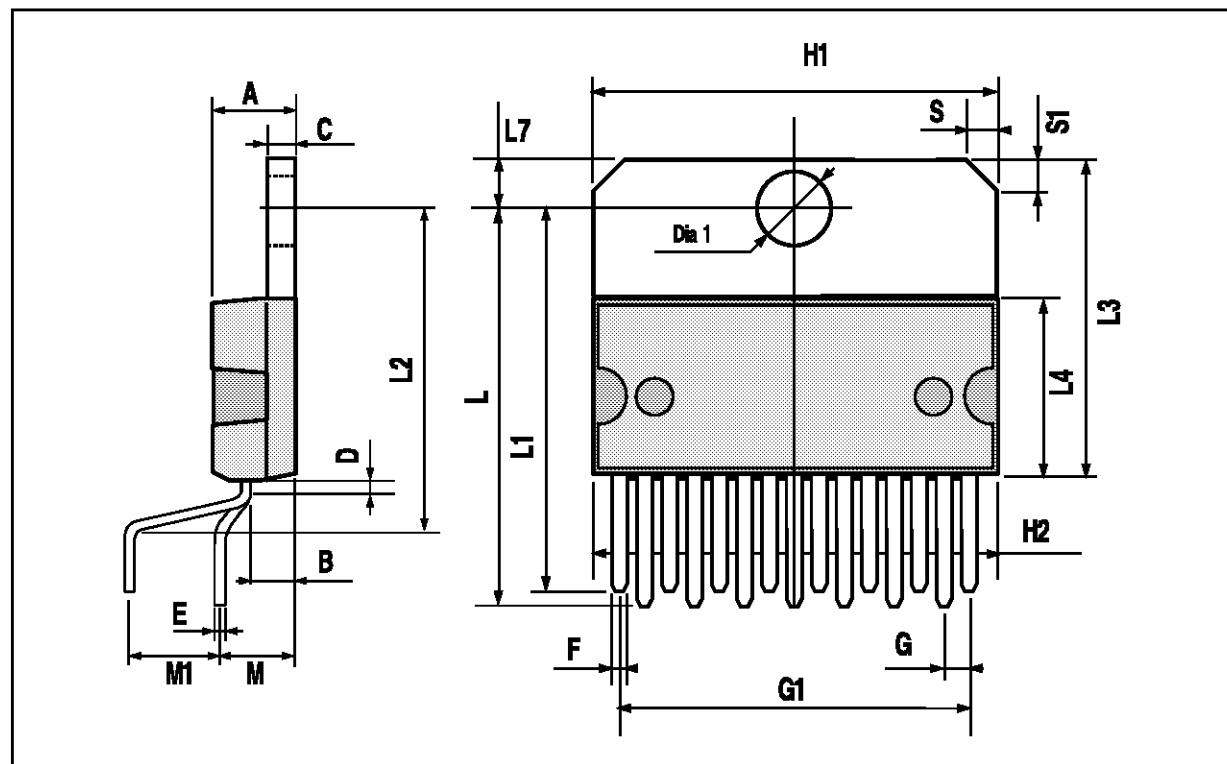

## POWERDIP 16 PACKAGE MECHANICAL DATA

DIM.	mm			inch		
	MIN.	TYP.	MAX.	MIN.	TYP.	MAX.
a1	0.51			0.020		
B	0.85		1.40	0.033		0.055
b		0.50			0.020	
b1	0.38		0.50	0.015		0.020
D			20.0			0.787
E		8.80			0.346	
e		2.54			0.100	
e3		17.78			0.700	
F			7.10			0.280
l			5.10			0.201
L		3.30			0.130	
Z			1.27			0.050

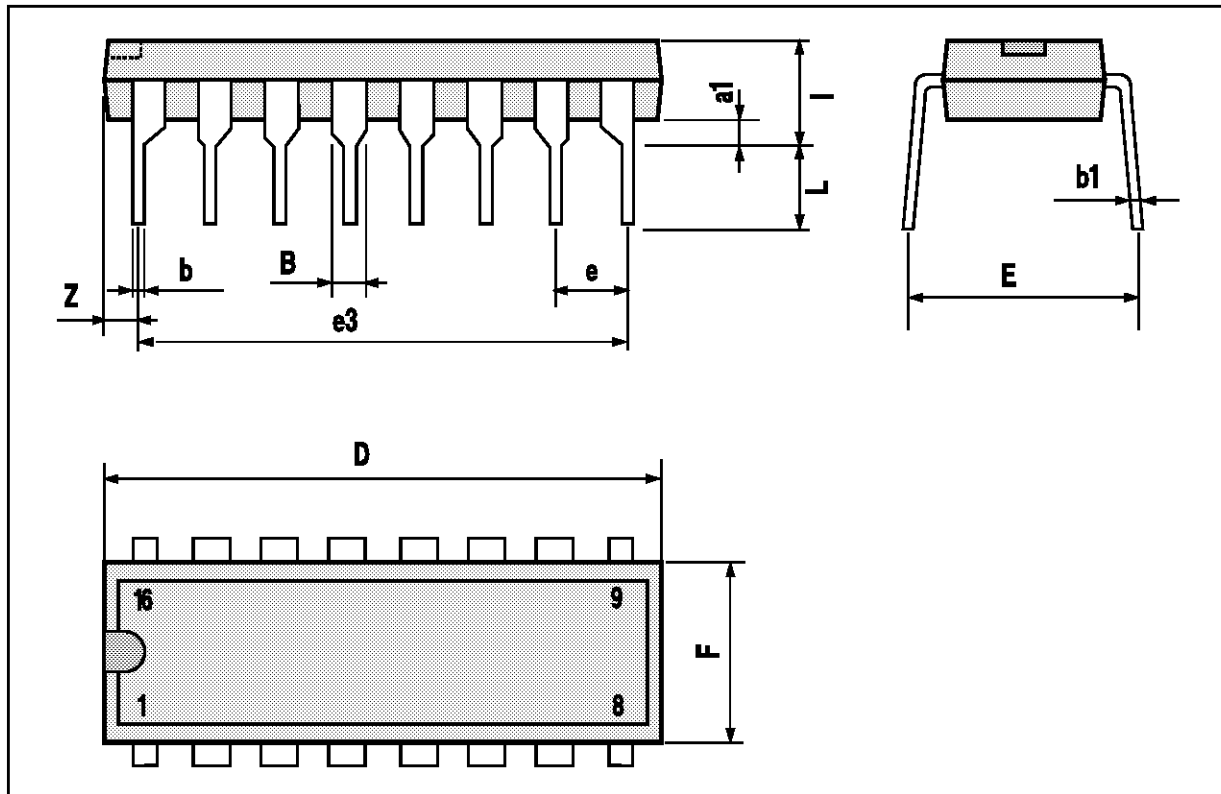

Information furnished is believed to be accurate and reliable. However, SGS-THOMSON Microelectronics assumes no responsibility for the consequences of use of such information nor for any infringement of patents or other rights of third parties which may result from its use. No license is granted by implication or otherwise under any patent or patent rights of SGS-THOMSON Microelectronics. Specifications mentioned in this publication are subject to change without notice. This publication supersedes and replaces all information previously supplied. SGS-THOMSON Microelectronics products are not authorized for use as critical components in life support devices or systems without express written approval of SGS-THOMSON Microelectronics.

© 1994 SGS-THOMSON Microelectronics - All Rights Reserved  
MULTIWATT® is a Registered Trademark of the SGS-THOMSON Microelectronics

SGS-THOMSON Microelectronics GROUP OF COMPANIES  
Australia - Brazil - France - Germany - Hong Kong - Italy - Japan - Korea - Malaysia - Malta - Morocco - The Netherlands - Singapore -  
Spain - Sweden - Switzerland - Taiwan - Thailand - United Kingdom - U.S.A.