

# TMC1173A/TMC1273

## Video A/D Converter

8 bit, 20 Msps, 3V

### Features

- 8-bit resolution
- 20 Msps conversion rate
- Low power: 15mW @ 5 Msps
- Integral track/hold
- Integral and differential linearity error 0.5 LSB
- Single +3V power supply
- Three-state TTL/CMOS-compatible outputs
- Low cost

### Applications

- Video digitizing
- VGA and CCD digitizing
- LCD projection panels
- Image scanners
- Personal computer video boards
- Multimedia systems
- Low cost, high speed data conversion

### Description

The TMC1173A/1273 analog-to-digital (A/D) converter employs a two-step architecture to convert analog signals into 8-bit digital words at sample rates of up to 20 Msps (Megasamples per second). An integral Track/Hold circuit delivers excellent performance on signals with full-scale frequency components up to 5 MHz. The innovative architecture and submicron CMOS technology limit typical power dissipation to 15 mW.

The TMC1173A/1273 operates from a single +2.7 to +3.6 Volt power supply and has internal voltage reference resistors for self-bias operation. Input capacitance is very low,

simplifying or eliminating input driving amplifiers. All digital three-state outputs are 3V TTL- and CMOS-compatible.

The TMC1173A and TMC1273 share their core architectures; the TMC1273 adds two overrange outputs that indicate when the analog input signal is beyond the conversion range.

The TMC1173A/1273 is available in 24-pin plastic DIP, 24-lead plastic SOIC, and 28-lead J-lead PLCC packages. Performance specifications are guaranteed from -20°C to 75°C.

### Block Diagram

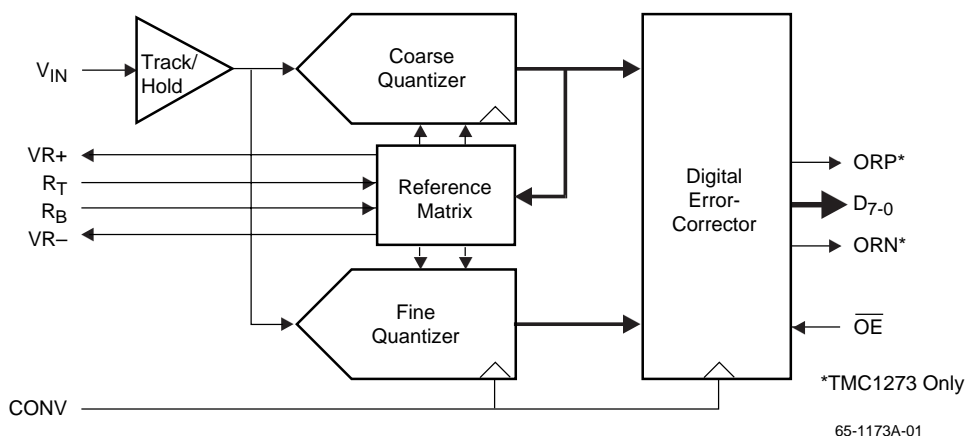

## Functional Description

The TMC1173A/1273 8-bit A/D converter uses a two-step architecture to perform analog-to-digital conversion at rates up to 20 Msps. The input signal is held in an integral track/hold stage during the conversion process. Operation is pipelined, with one input sample taken and one output word provided for each CONVert cycle.

The first step in the conversion process is a coarse 4-bit quantization. This determines the range of the subsequent fine 4-bit quantization step. To eliminate spurious codes, the fine 4-bit A/D quantizer output is gray-coded and converted to binary before it is combined with the coarse result to form a complete 8-bit result.

The TMC1173A/1273 is characterized and specified for use in “3 Volt” applications where the power supply voltage can be as low as 2.7V.

### Analog Input and Voltage References

The TMC1173A/1273 converts analog signals in the range  $R_B$  to  $R_T$  into digital data. Input signals outside that range produce “saturated” 00h or FFh output codes. The device will not be damaged by signals within the range AGND to  $V_{DDA}$ .

The A/D converter input range is very flexible and extends from the +3.3 Volt power supply to ground. The nominal input range is 1.56 Volts, from 0.36V to 1.92V. The circuit is characterized and performance is specified over that range. However, the part will work well with a full-scale range from 1.0V to 3.0V. A reduced input range may simplify analog signal conditioning circuitry, at the expense of additional noise sensitivity and some reduced differential linearity performance. Similarly, increasing the range can improve differential linearity, but puts a greater burden on the input signal conditioning circuitry.

In many applications, external voltage reference sources are connected to the  $R_T$  and  $R_B$  pins.  $R_B$  can be grounded. Gain and offset errors are directly related to the accuracy and stability of the applied reference voltages.

Two reference pull-up and pull-down resistors connected to  $VR+$  and  $VR-$ , are provided internally for operation without external voltage reference circuitry (Figure 1). The reference voltages applied to  $R_T$  and  $R_B$  may be generated by connect-

ing  $VR+$  to  $R_T$  and  $VR-$  to  $R_B$ . The power supply voltage is divided by the on-chip resistors to bias the  $R_T$  and  $R_B$  points. This sets-up the converter for operation in its nominal range from 0.4V to 1.6V.

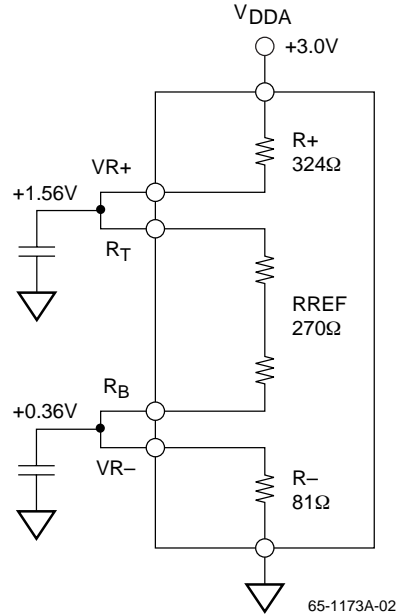

Figure 1. Reference Resistors

With  $V_{DDA}$  at 3.0V, connecting  $VR+$  to  $R_T$  and grounding  $R_B$  will provide an input range from 0.0V to 1.36V, while connecting  $R_T$  to  $V_{DDA}$  and  $R_B$  to  $VR-$  produces a full scale range of 2.31V referenced to  $V_{DDA}$ . External resistors may also be employed to provide arbitrary reference voltages, but they will not match the temperature coefficient of the on-chip resistors as well as  $R+$  and  $R-$ , and will cause the converter transfer function to vary with temperature.

With this implementation, errors in the power supply voltage end up on the conversion data output.

Because a two-step conversion process is employed, it is important that the references remain stable during the ENTIRE conversion process (two clock cycles). The reference voltage can then be changed, but any conversion in progress during a reference change is invalid.

**Table 1. Output Coding**

Input Voltage	ORP <sup>2</sup>	ORN <sup>2</sup>	Output
$R_T + 1 \text{ LSB}$	1	0	FF
$R_T$	0	0	FF
$R_T - 1 \text{ LSB}$	0	0	FE
...	...	...	...
$R_B + 128 \text{ LSB}$	0	0	80
$R_B + 127 \text{ LSB}$	0	0	7F
...	...	...	...
$R_B + 1 \text{ LSB}$	0	0	01
$R_B$	0	0	00
$R_B - 1 \text{ LSB}$	0	1	00

**Notes:**

1.  $\text{LSB} = (R_T - R_B) / 255$
2. TMC1273 Only

**Digital Inputs and Outputs**

Sampling of the applied input signal takes place on the falling edge of the CONV signal (Figure 2). The output word is delayed by 2 1/2 CONV cycles. It is then available after the

rising edge of CONV. The previous data on the output remain valid for  $t_{HO}$  (Output Hold Time), satisfying any hold time requirement of the receiving circuit. The new data become valid  $t_{DO}$  (Output Delay Time) after this rising edge of CONV.

Whenever the analog input signal is sampled and found to be at a level beyond the A/D conversion range, an Overrange output of the TMC1273 will go HIGH. If the input is more positive (by at least one LSB) than the positive end of the range, ORP will go HIGH and D7-0 will be FFh. If the input is more negative (by at least one LSB) than the negative end of the range, ORN will go HIGH and D7-0 will be 00h.

The outputs of the TMC1173A/1273 are CMOS- and 3V TTL-compatible, and are capable of driving four low-power Schottky TTL (54/74LS) loads. An Output Enable control,  $\overline{OE}$ , places the outputs in a high-impedance state when HIGH. The outputs are enabled when  $\overline{OE}$  is LOW.

**Power and Ground**

The TMC1173A/1273 operates from a single +2.7 to +3.6 Volt power supply. For optimum performance, it is recommended that AGND and DGND pins of the TMC1173A/1273 be connected to the system analog ground plane.

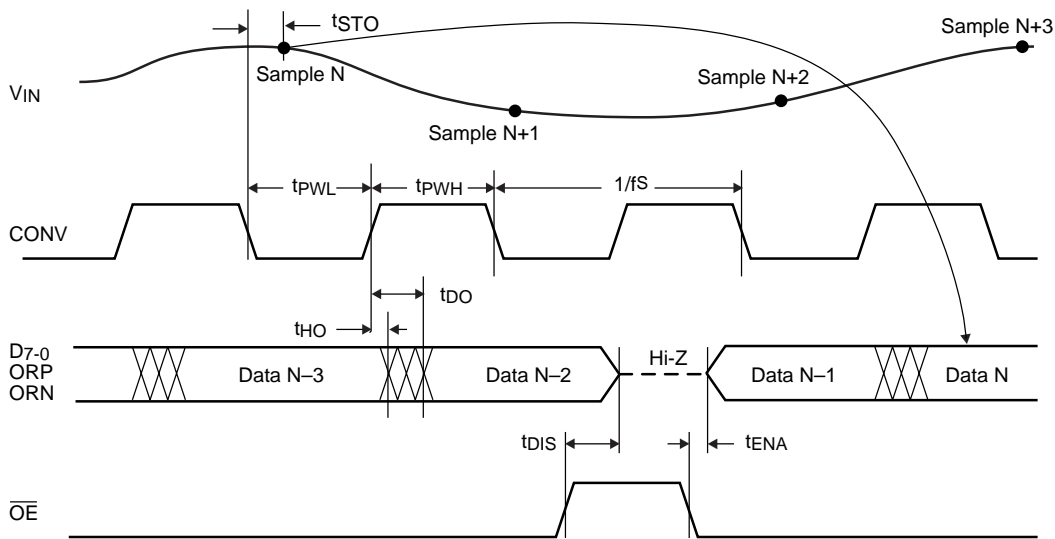

**Figure 2. Conversion Timing**

65-1173A-03

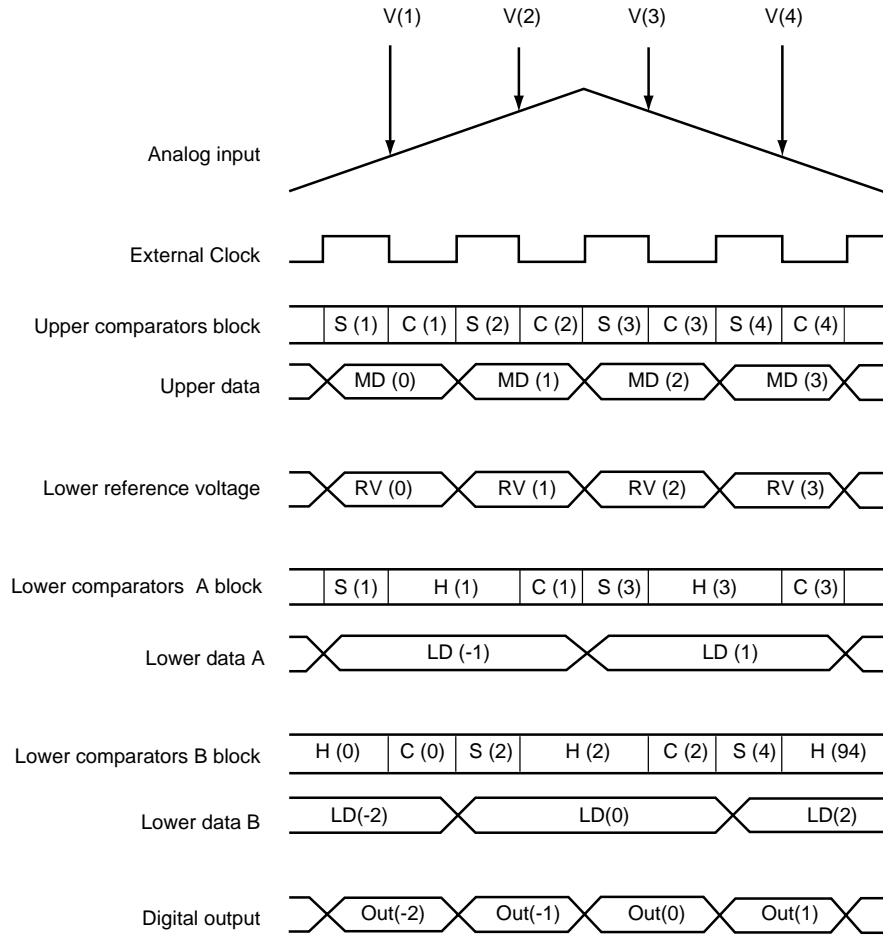

65-1173A-04

**Figure 3. Internal Timing**

## Pin Assignments

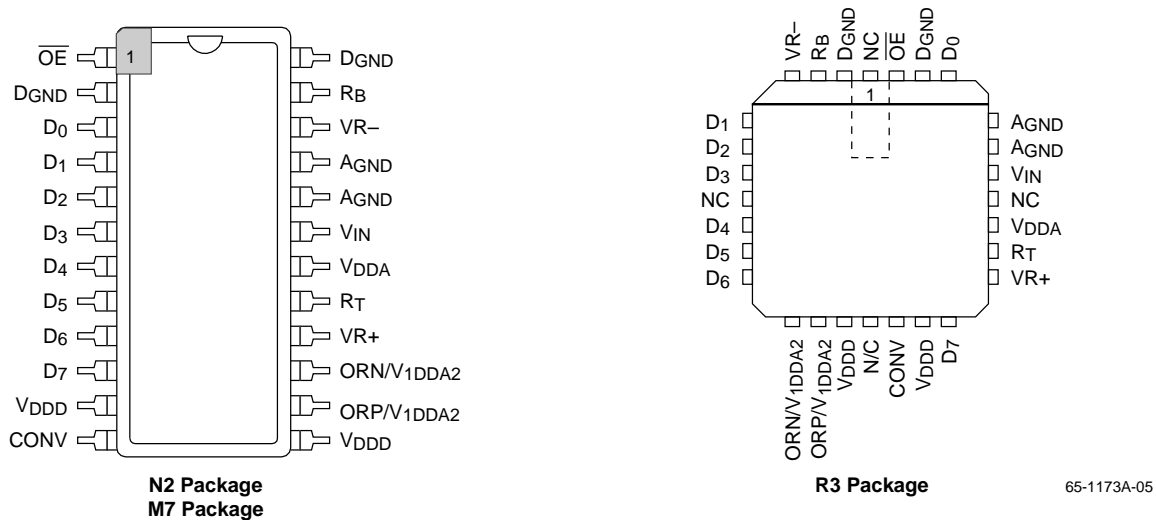

## Pin Description

Pin Name	Pin Number		Pin Type	Pin Function Description
	N2, M7	R3		
<b>Inputs</b>				
V <sub>IN</sub>	19	23	RT – RB	<b>Analog Input.</b> The input voltage conversion range lies between the voltages applied to the RT and RB pins.
RT	17	20	1.6V	<b>Reference Voltage Top Input.</b> RT is the top input to the reference resistor ladder. A DC voltage applied to RT defines the positive end of the V <sub>IN</sub> conversion range.
RB	23	27	0.4V	<b>Reference Voltage Bottom Input.</b> RB is the bottom input to the reference resistor ladder. A DC voltage applied to RB defines the negative end of the V <sub>IN</sub> conversion range.
VR+	16	19		<b>Reference Voltage Top Source.</b> VR+ is the internal pull-up reference resistor for self-bias operations.
VR-	22	26		<b>Reference Voltage Bottom Source.</b> VR- is the internal pull-down reference resistor for self-bias operations.
OE	1	2	CMOS	<b>Output Enable.</b> (CMOS-compatible) When LOW, D7-0 are enabled. When HIGH, D7-0 are in a high-impedance state.
CONV	12	14	CMOS	<b>Convert (Clock) Input.</b> (CMOS-compatible) V <sub>IN</sub> is sampled on the falling edge of CONV.
<b>Outputs</b>				
D7-0	10–3	12–9, 7–4	CMOS/ 3V TTL	<b>Data Outputs (D7 = MSB).</b> Eight-bit CMOS- and 3V TTL-compatible digital outputs. Data is output following the rising edge of CONV.
ORP <sup>1</sup>	14 <sup>1</sup>	17 <sup>1</sup>	CMOS/ 3V TTL	<b>OverRange Positive Output.</b> When HIGH, ORP indicates that the analog input voltage is at least one LSB higher than the voltage that produces output code FFh. ORP is synchronous with D7-0.
ORN <sup>1</sup>	15 <sup>1</sup>	18 <sup>1</sup>	CMOS/ 3V TTL	<b>OverRange Negative Output.</b> When HIGH, ORN indicates that the analog input voltage is at least one LSB lower than the voltage that produces output code 00h. ORN is synchronous with D7-0.

## Pin Description (continued)

Pin Name	Pin Number		Pin Type	Pin Function Description
	N2, M7	R3		
<b>Power</b>				
VDDA	14 <sup>2</sup> , 15 <sup>2</sup> , 18	17 <sup>2</sup> , 18 <sup>2</sup> , 21	+3.3V	<b>Analog Supply Voltage.</b> These should originate from a common +3.3V source and be decoupled to AGND.
VDDD	11, 13	13, 16	+3.3V	<b>Digital Supply Voltage.</b> +3.3 Volt power inputs. These should originate from a common +3.3V power source and be decoupled to AGND.
AGND	20, 21	24, 25	0.0V	<b>Analog Ground.</b> Connect to the system analog ground plane.
DGND	2, 24	3, 28	0.0V	<b>Digital Ground.</b> Connect to the system analog ground plane.
<b>No Connect</b>				
N/C		1, 8, 15, 22	open	Not Connected.

**Notes:**

1. TMC1273 Only.
2. TMC1173A Only.

## Specification Notes

### Bandwidth

The specification for bandwidth of an A/D converter is somewhat different from the normal frequency-response specification used in amplifiers and filters. An understanding of the differences will help in selecting converters properly for particular applications.

A/D conversion comprises two distinct processes: sampling and quantizing. Sampling is “grabbing” a snapshot of the input signal and holding it steady for quantizing. The quantizing process is approximating the analog input, which may be any value within the conversion range, with its nearest numerical value. While sampling is a high-frequency process, quantizing operates on a dc signal, held steady by the track/hold circuit. Therefore, the sampling process is what relates to the dynamic characteristics of the converter.

Sampling involves an aperture time, the time during which the track/hold is trying to capture the input signal and settle on a dc value to hold. It is analogous to the shutter speed of a camera: the shorter the aperture (or faster the shutter) the less the signal will be blurred, and the less uncertainty there will be in the quantized value.

For example, a 10 MHz sinewave with a 1V peak amplitude (2Vp-p) has a maximum slew rate of  $2\pi fA$  at zero crossing, or  $62.8V/\mu s$ . With an 8-bit A/D converter,  $q$  (the quantization step size) =  $2V/255 = 7.8mV$ . The input signal will slew one LSB in 124ps. To limit the error (and noise) contribution due to aperture effects to  $1/2LSB$ , the aperture must be shorter than 62ps.

This is the primary reason that the signal to noise ratio drops off as full scale frequency increases. Note, also, that the slew rate is directly proportional to signal amplitude. A. A/Ds will handle lower-amplitude signals of higher bandwidth.

All this is of particular interest in applications such as digitizing analog VGA RGB signals, or the output of a CCD imaging chip. These data are effectively pre-sampled: there is a period of rapid slewing from one pixel value to another, followed by a relatively stable dc level before the signal slews to the next pixel value. The goal is, of course, to sample on these pixel values, not on the slewing between pixels. During the aperture time, the A/D sees essentially a dc signal, and classic bandwidth considerations are not important. As long as the input circuit can slew and settle to the new value in the prescribed period, an accurate conversion will be made.

The TMC1173A/1273 is capable of slewing a full 2V and settling between samples taken as little as 25ns apart, making it ideal for digitizing analog VGA and CCD outputs.

### Equivalent Circuits and Threshold Level

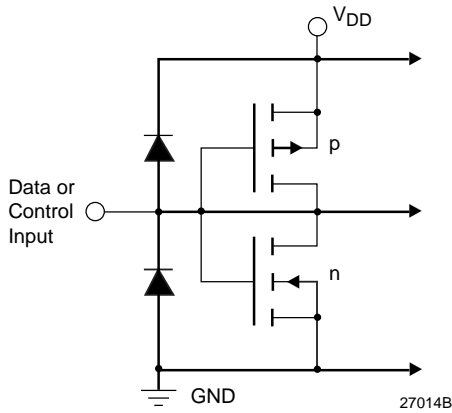

Figure 4. Equivalent Digital Input Circuit

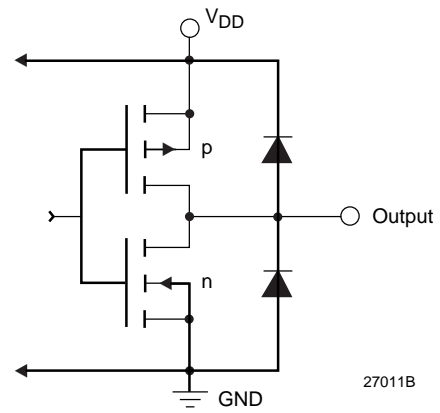

Figure 5. Equivalent Digital Output Circuit

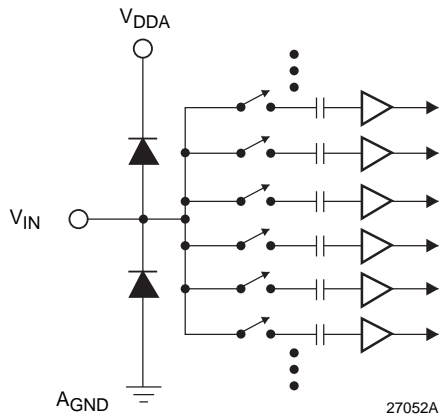

Figure 6. Equivalent Analog Input Circuit

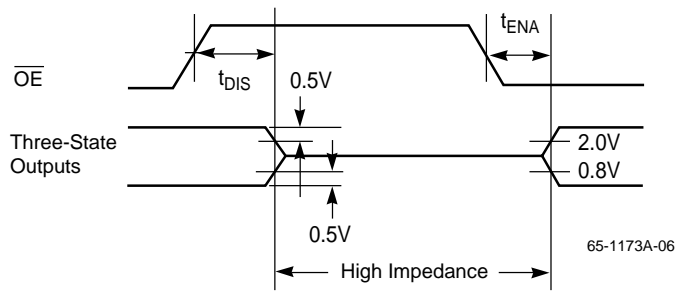

Figure 7. Threshold Levels for Three-State Measurements

Preliminary Information

## Absolute Maximum Ratings

(beyond which the device may be damaged)<sup>1</sup>

Parameter	Conditions	Min	Max	Unit
<b>Power Supply Voltages</b>				
VDDA	Measured to AGND	-0.5	7.0	V
VDDD	Measured to DGND	-0.5	7.0	V
VDDA	Measured to VDDD	-0.5	0.5	V
AGND	Measured to DGND	-0.5	0.5	V
<b>Digital Inputs</b>				
Applied Voltage <sup>2</sup>	Measured to DGND	-0.5	VDDD + 0.5	V
Forced Current <sup>3,4</sup>		-10.0	10.0	mA
<b>Analog Inputs</b>				
Applied Voltage <sup>2</sup>	Measured to AGND	-0.5	VDDA + 0.5	V
Forced Current <sup>3,4</sup>		-10.0	10.0	mA
<b>Outputs</b>				
Applied Voltage <sup>2</sup>	Measured to DGND	-0.5	VDDD + 0.5	V
Forced Current <sup>3,4</sup>		-6.0	6.0	mA
Short Circuit Duration	Single output in HIGH state to ground		1	sec
<b>Temperature</b>				
Operating, ambient		-20	110	°C
Junction			150	°C
Storage		-65	150	°C
Lead Soldering	10 seconds		300	°C
Vapor Phase Soldering	1 minute		220	°C

**Notes:**

- Functional operation under any of these conditions is NOT implied. Performance and reliability are guaranteed only if Operating Conditions are not exceeded.
- Applied voltage must be current limited to specified range.
- Forcing voltage must be limited to specified range.
- Current is specified as conventional current flowing into the device.

## Operating Conditions

Parameter		Min	Nom	Max	Units
VDDD	Digital Power Supply Voltage	2.7	3.0	3.6	V
VDDA	Analog Power Supply Voltage	2.7	3.0	3.6	V
AGND	Analog Ground (Measured to DGND)	-0.1	0	0.1	V
fs	Conversion Rate	TMC1173A/1273-5		5	Msps
		TMC1173A/1273-10		10	
		TMC1173A/1273-20		20	
tPWH	CONV Pulsewidth, HIGH	20			ns
tPWL	CONV Pulsewidth, LOW	17			ns
VRT	Reference Voltage, Top	1.5	1.56	VDDA	V
VRB	Reference Voltage, Bottom	0	0.36	1.5	V
VRT-VRB	Reference Voltage Differential	1.0		3.0	V

Preliminary Information

**Operating Conditions** (continued)

Parameter		Min	Nom	Max	Units
V <sub>IN</sub>	Analog Input Range	V <sub>RB</sub>		V <sub>RT</sub>	V
V <sub>IH</sub>	Input Voltage, Logic HIGH	0.85 x V <sub>DDD</sub>		V <sub>DDD</sub>	V
V <sub>IL</sub>	Input Voltage, Logic LOW	GND		0.2 x V <sub>DDD</sub>	V
I <sub>OH</sub>	Output Current, Logic HIGH			-1.0	mA
I <sub>OL</sub>	Output Current, Logic LOW			2.0	mA
T <sub>A</sub>	Ambient Temperature, Still Air	-20		75	°C

**Electrical Characteristics**

Parameter		Conditions	Min	Typ <sup>1</sup>	Max	Units
I <sub>DD</sub>	Power Supply Current <sup>1</sup>	V <sub>DDD</sub> = V <sub>VDDA</sub> = Max, C <sub>LOAD</sub> = 35pF				mA
		f <sub>S</sub> = 5Msps		5	12	
		f <sub>S</sub> = 10Msps		8	15	
		f <sub>S</sub> = 20Msps		14	24	
I <sub>DDQ</sub>	Power Supply Current, Quiescent	V <sub>DDD</sub> = V <sub>VDDA</sub> = Max				mA
		CONV = LOW		2	9	
		CONV = HIGH		3	11	
P <sub>D</sub>	Total Power Dissipation	V <sub>DDD</sub> = V <sub>VDDA</sub> = Max, C <sub>LOAD</sub> = 35pF				mW
		f <sub>S</sub> = 5Msps		15	45	
		f <sub>S</sub> = 10Msps		24	55	
		f <sub>S</sub> = 20Msps		42	86	
C <sub>AI</sub>	Input Capacitance, Analog	CONV = LOW		4		pF
		CONV = HIGH		12		pF
R <sub>IN</sub>	Input Resistance		500	1000		kΩ
I <sub>CB</sub>	Input Current, Analog				±1	μA
R <sub>REF</sub>	Reference Resistance		200	270	340	Ω
I <sub>IH</sub>	Input Current, HIGH	V <sub>DDD</sub> = Max, V <sub>IN</sub> = V <sub>DDD</sub>			±5	μA
I <sub>IL</sub>	Input Current, LOW	V <sub>DDD</sub> = Max, V <sub>IN</sub> = 0V			±5	μA
I <sub>OZH</sub>	Hi-Z Output Leakage	V <sub>DDD</sub> = Max, V <sub>IN</sub> = V <sub>DDD</sub>			±5	μA
I <sub>OZL</sub>	Hi-Z Output Leakage	V <sub>DDD</sub> = Max, V <sub>IN</sub> = 0V			±5	μA
I <sub>OS</sub>	Short-Circuit Current				-30	mA
V <sub>OH</sub>	Output Voltage, HIGH	I <sub>OH</sub> = -100μA	V <sub>DDD</sub> -0.3			V
		I <sub>OH</sub> = -0.5mA	2.5			V
		I <sub>OH</sub> = Max	2.1			V
V <sub>OL</sub>	Output Voltage, LOW	I <sub>OL</sub> = Max			0.3	V
C <sub>DI</sub>	Digital Input Capacitance			4	10	pF
C <sub>DO</sub>	Digital Output Capacitance			10		pF

**Note:**

1. Typical values with V<sub>DDD</sub> = V<sub>VDDA</sub> = Nom and T<sub>A</sub> = Nom, Minimum/Maximum values with V<sub>DDD</sub> = V<sub>VDDA</sub> = Max and T<sub>A</sub> = Min.

### Switching Characteristics

Parameter		Conditions	Min	Typ	Max	Units
tSTO	Sampling Time Offset		3	5	8	ns
tHO	Output Hold Time	CLOAD = 15pF	5			ns
tDO	Output Delay Time	CLOAD = 15pF			32	ns
tENA	Output Enable Time				40	ns
tDIS	Output Disable Time				45	ns

### System Performance Characteristics

Parameter		Conditions	Min	Typ <sup>1</sup>	Max	Units
ELI	Integral Linearity Error, Independent	$V_{RT} - V_{RB} \geq 1.2V$		±0.5	±0.75	LSB
ELD	Differential Linearity Error	$V_{RT} - V_{RB} \geq 1.2V$		±0.5	±0.75	LSB
BW	Bandwidth <sup>2</sup>	TMC1173A/1273-5			5	MHz
		TMC1173A/1273-10			5	
		TMC1173A/1273-20			10	
EAP	Aperture Error			50		ps
EOT	Offset Voltage, Top	$R_T - V_{IN}$ for most positive code transition	-25	-2	25	mV
EOB	Offset Voltage, Bottom	$R_B - V_{IN}$ for most negative code transition	15	20	45	mV

**Notes:**

1. Values shown in Typ column are typical for  $V_{DDD} = V_{DDA} = +3.0V$  and  $T_A = 25^\circ C$ .
2. Bandwidth is the frequency up to which a full-scale sinewave can be digitized without spurious codes.

### System Performance Characteristics

Parameter		Conditions	Min	Typ	Max	Units	
SNR	Signal-to-Noise Ratio	$f_S = 5Msps, V_{IN} = 1.2V$ p-p					dB
		$f_{IN} = 1.24MHz$	42	47			
		$f_{IN} = 2.48MHz$	41	46			
		$f_S = 10Msps, V_{IN} = 1.2V$ p-p					dB
		$f_{IN} = 1.24MHz$	42	47			
		$f_{IN} = 2.48MHz$	40	45			
		$f_{IN} = 4.96MHz$	34	39			
		$f_S = 20Msps, V_{IN} = 1.2V$ p-p					dB
		$f_{IN} = 1.24MHz$	38	44			
		$f_{IN} = 2.48MHz$	37	42			
		$f_{IN} = 6.98MHz$	26	32			
		$f_{IN} = 10MHz$	25	30			

Preliminary Information

### System Performance Characteristics (continued)

Parameter	Conditions	Min	Typ	Max	Units	
SFDR	Spurious-Free Dynamic Range	$f_S = 5\text{Mpsps}, V_{IN} = 1.2\text{V p-p}$				dB
		$f_{IN} = 1.24\text{MHz}$	37	43		
		$f_{IN} = 2.48\text{MHz}$	32	37		
		$f_S = 10\text{Mpsps}, V_{IN} = 1.2\text{V p-p}$				dB
		$f_{IN} = 1.24\text{MHz}$	37	43		
		$f_{IN} = 2.48\text{MHz}$	32	37		
	$f_S = 20\text{Mpsps}, V_{IN} = 1.2\text{V p-p}$				dB	
	$f_{IN} = 1.24\text{MHz}$	34	40			
	$f_{IN} = 2.48\text{MHz}$	31	37			
	$f_{IN} = 6.98\text{MHz}$	25	31			
		$f_{IN} = 10\text{MHz}$	22	28		

**Notes:**

1. SNR values do not include the harmonics of the fundamental frequency.
2. SFDR is the ratio in dB of fundamental amplitude to the harmonic with the highest amplitude.
3. Values shown in Typ column are typical for  $V_{DD} = V_{DDA} = +3.3\text{V}$  and  $T_A = 25^\circ\text{C}$ .

### Typical Performance Characteristics

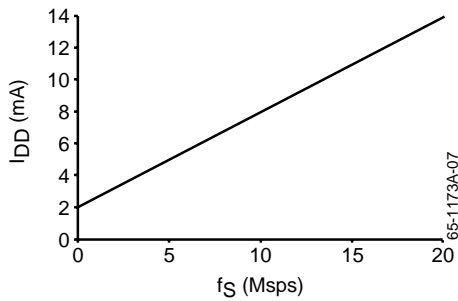

Figure 8. Typical  $I_{DD}$  vs  $f_S$

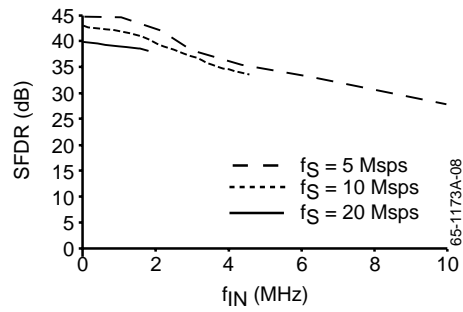

Figure 9. Typical SFDR vs  $f_{IN}$  and  $f_S$

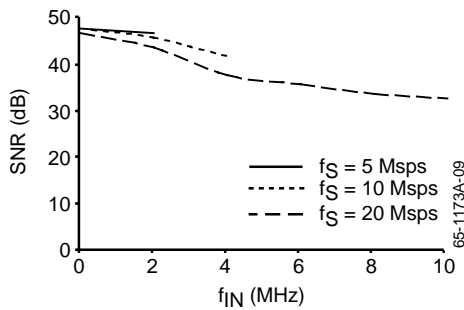

Figure 10. Typical SNR vs  $f_{IN}$  and  $f_S$

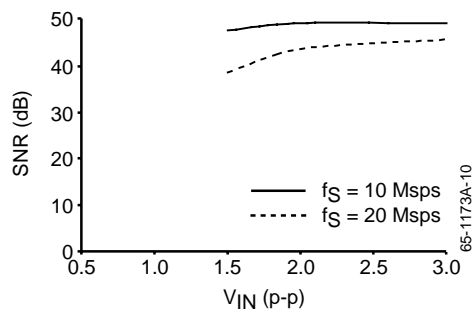

Figure 11. Typical SNR vs Full Scale Input Range

Preliminary Information

## Applications Discussion

The circuit in Figure 12 employs a band-gap reference to generate a variable  $R_T$  reference voltages for the TMC1173A/1273 as well as a bias voltage to offset the inverting wideband input amplifier to mid-range. An "offset adjust" is also shown for varying the mid-range voltage level. The operational amplifier in the reference circuitry is a standard 741-type.

The voltage reference at  $R_T$  can be adjusted from 0.0 to 2.4 volts while  $R_B$  is grounded. Diodes are used to restrict the wideband amplifier output to between  $-0.7V$  and  $V_{DD} + 0.7V$ . Diode protection is good practice to limit the analog input voltage at  $V_{IN}$  to the safe operating range.

The circuit in Figure 13 shows self-bias of  $R_T$  and  $R_B$  by connection to  $VR+$  and  $VR-$ . This sets up a 0.4 to 1.7 Volt input range for  $V_{IN}$ . The input range is susceptible to power supply variation since the voltages on  $R_T$  and  $R_B$  are directly derived from  $V_{DDA}$ . The video input is AC-coupled and biased at a adjustable midpoint of the A/D input range. This circuit offers the advantage of minimum support circuitry for the most cost-sensitive applications.

In Figure 14, an external band-gap reference sets  $R_T$  to  $+1.2$  Volts while  $R_B$  is grounded. The internal pull-up resistor,  $R+$ , provides the bias current for the band-gap reference. The A/D converter input is biased to the mid-point of the input range.

### Grounding

The TMC1173A/1273 has separate analog and digital circuits. To keep digital system noise from the A/D converter, it is recommended that power supply voltages ( $V_{DDD}$  and  $V_{DDA}$ ) come from the same source, and that ground connections ( $DGND$  and  $AGND$ ) be made to the analog ground plane. Power supply pins should be individually decoupled at the pin. The digital circuitry that gets its input from the TMC1173A/1273 should be referred to the system digital ground plane.

### Printed Circuit Board Layout

Designing with high performance mixed-signal circuits demands printed circuits with ground planes. Wire-wrap is likely to degrade performance. Overall system performance is strongly influenced by the board layout. Capacitive coupling from digital to analog circuits may result in poor A/D conversion. Consider the following suggestions when doing the layout:

1. Keep the critical analog traces ( $V_{IN}$ ,  $R_T$ ,  $R_B$ ,  $VR+$ ,  $VR-$ ) as short as possible and as far as possible from all digital signals. The TMC1173A/1273 should be located near the board edge, close to the analog input connectors.
2. The power plane for the TMC1173A/1273 should be separate from that which supplies the rest of the digital circuitry. A single power plane should be used for all of the  $V_{DD}$  pins. If the power supply for the TMC1173A/1273 is the same as that of the system's digital circuitry, power to the TMC1173A/1273 should be decoupled with ferrite beads and  $0.1\mu F$  capacitors to reduce noise.
3. The ground plane should be solid, not cross-hatched. Connections to the ground plane should have very short leads.
4. Decoupling capacitors should be applied liberally to  $V_{DD}$  pins. Remember that not all power supply pins are created equal. They supply different circuits on the integrated circuit, each of which generate varying amounts and types of noise. For best results, use  $0.1\mu F$  ceramic capacitors. Lead lengths should be minimized. Ceramic chip capacitors are the best choice.
5. If the digital power supply has a dedicated power plane layer, it should not be placed under the TMC1173A/1273, the voltage reference, or the analog inputs. Capacitive coupling of digital power supply noise from this layer to the TMC1173A/1273 and its related analog circuitry can have an adverse effect on performance.
6.  $CONV$  should be handled carefully. Jitter and noise on this clock may degrade performance. Terminate the clock line carefully to eliminate overshoot and ringing.

### Evaluation Board

An evaluation board is available that implements good interface practices and provide a convenient testbed for developing system applications and circuit variations. An on-board D/A converter is provided to reconstruct the digitized signal and to evaluate converter performance.

Contact your sales representative for information.

### Typical Interface Circuits

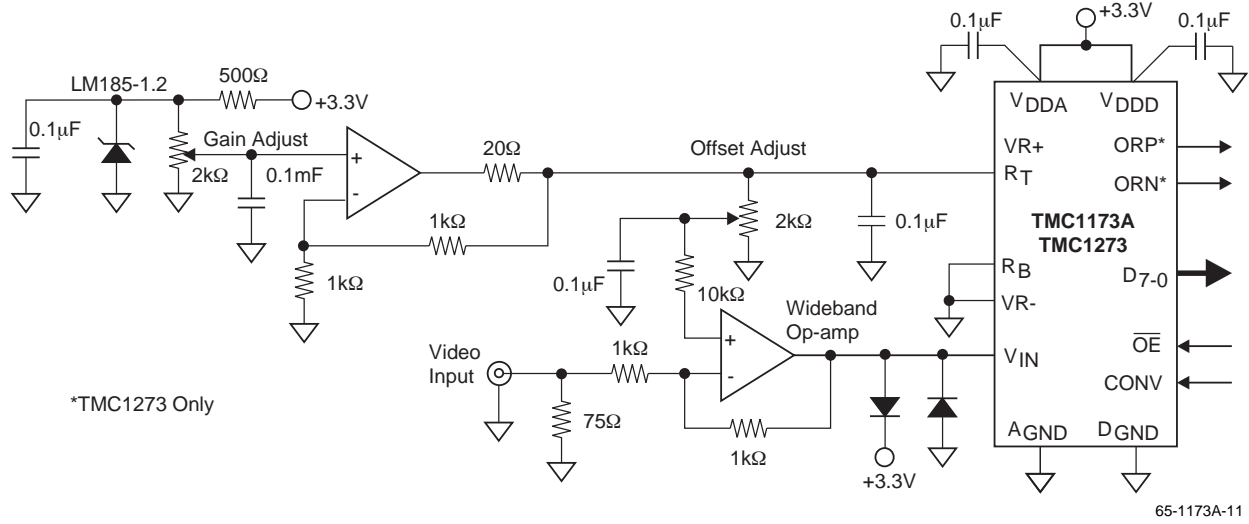

Figure 12. High Performance Circuit

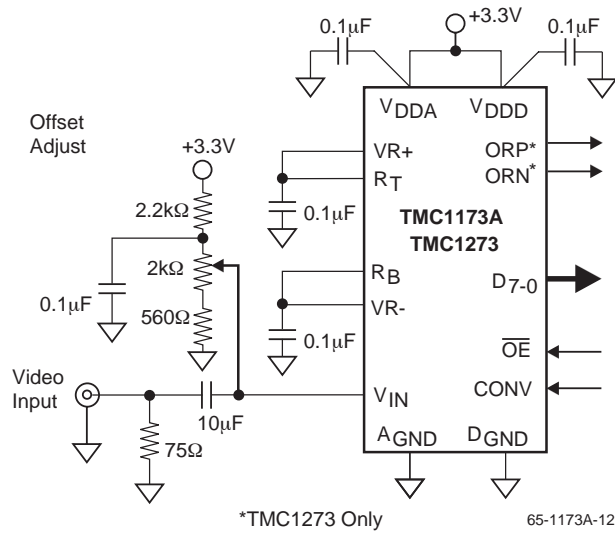

Figure 13. Low Cost Circuit

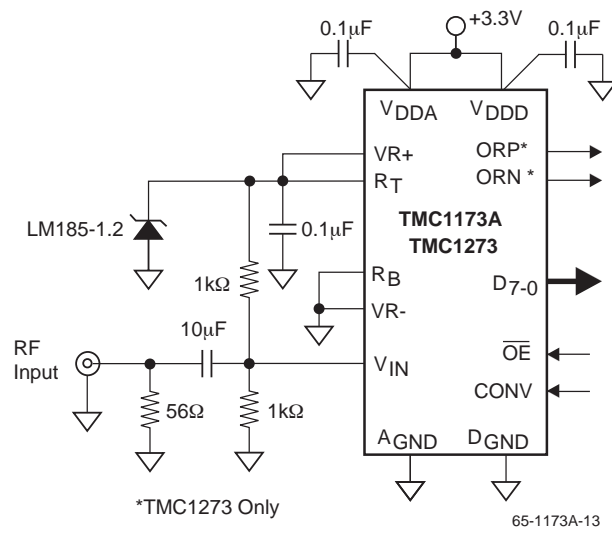

Figure 14. Stabilized Reference Circuit

Preliminary Information

**Notes:**

Preliminary Information

**Notes:**

Preliminary Information

**Notes:**

Preliminary Information

# Mechanical Dimensions

## 24 Lead SOIC (M7) Package

Symbol	Inches		Millimeters		Notes
	Min.	Max.	Min.	Max.	
A	.067	.075	1.70	1.90	
A1	.004	.012	0.10	0.31	
B	.014	.020	0.36	0.51	
C	.006	.012	0.15	0.30	
D	.587	.610	14.90	15.50	
E	.205	.220	5.20	5.60	
E1	.295	.319	7.50	8.10	
e	.050 BSC		1.27 BSC		
h	.010	.020	0.25	0.50	
L	.016	.050	0.41	1.27	
N	24		24		
$\alpha$	0°	8°	0°	8°	
ccc	—	.004	—	0.10	

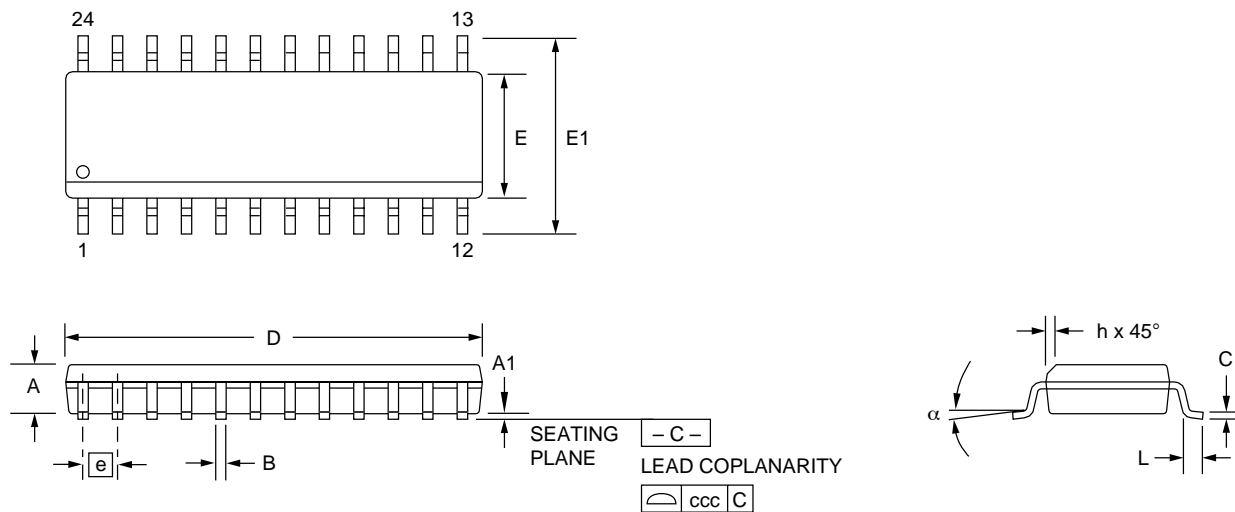

Preliminary Information

# Mechanical Dimensions (continued)

## 24 Lead Plastic DIP (N2) Package

Symbol	Inches		Millimeters		Notes
	Min.	Max.	Min.	Max.	
A	—	.210	—	5.33	
A1	.015	—	.38	—	
A2	.115	.195	2.53	4.95	
B	.014	.022	.36	.56	
B1	.045	.070	1.14	1.78	
C	.008	.015	.20	.38	4
D	1.125	1.275	28.58	32.39	2
D1	.005	—	.13	—	
E	.300	.325	7.62	8.26	
E1	.240	.280	6.10	7.11	2
e	.100 BSC		2.54 BSC		
eB	—	.430	—	10.92	
L	.115	.160	2.92	4.06	
N	24		24		5

**Notes:**

1. Dimensioning and tolerancing per ANSI Y14.5M-1982.
2. "D" and "E1" do not include mold flashing. Mold flash or protrusions shall not exceed .010 inch (0.25mm).
3. Terminal numbers are shown for reference only.
4. "C" dimension does not include solder finish thickness.
5. Symbol "N" is the maximum number of terminals.

Preliminary Information

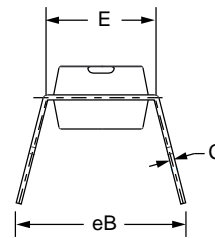
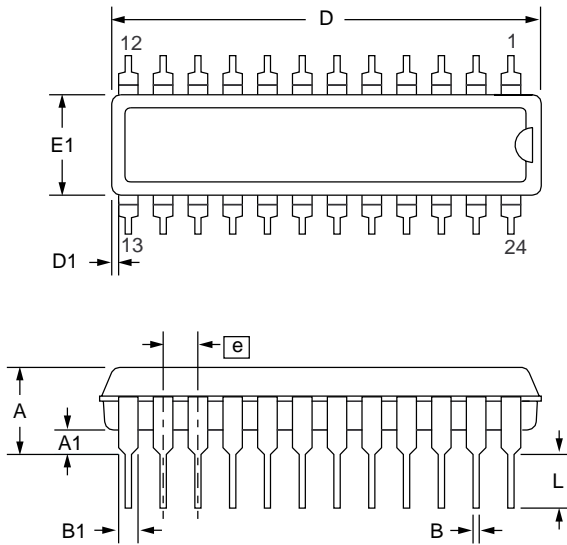

# Mechanical Dimensions (continued)

## 28 Lead PLCC (R3) Package

Symbol	Inches		Millimeters		Notes
	Min.	Max.	Min.	Max.	
A	.165	.180	4.20	4.57	
A1	.090	.120	2.29	3.04	
A2	.020	—	.51	—	
B	.013	.021	.33	.53	
B1	.026	.032	.66	.81	
D/E	.485	.495	12.32	12.57	
D1/E1	.450	.456	11.43	11.58	3
D3/E3	.300 BSC		7.62 BSC		
e	.050 BSC		1.27 BSC		
J	.042	.056	1.07	1.42	2
ND/NE	7		7		
N	28		28		
ccc	—	.004	—	0.10	

**Notes:**

1. All dimensions and tolerances conform to ANSI Y14.5M-1982.
2. Corner and edge chamfer (J) = 45°.
3. Dimension D1 and E1 do not include mold protrusion. Allowable protrusion is .245mm/.101in.

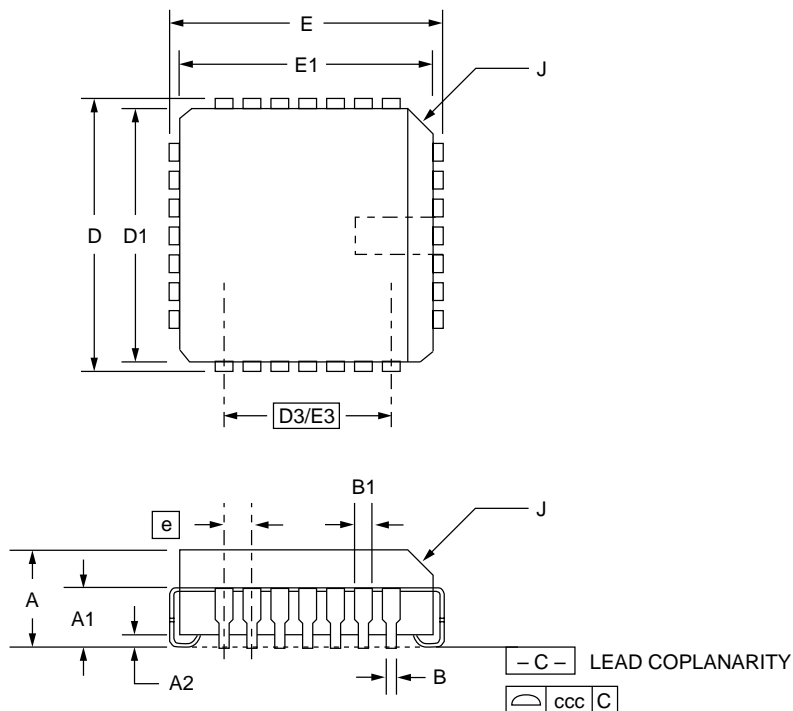

Preliminary Information

## Ordering Information

Product Number	Conversion Rate	Temperature Range	Screening	Package	Package Marking
TMC1173AM7C5	5 Msps	T <sub>A</sub> = -20°C to 75°C	Commercial	24-Lead SOIC	1173AM7C5
TMC1173AM7C10	10 Msps	T <sub>A</sub> = -20°C to 75°C	Commercial	24-Lead SOIC	1173AM7C10
TMC1173AM7C20	20 Msps	T <sub>A</sub> = -20°C to 75°C	Commercial	24-Lead SOIC	1173AM7C20
TMC1173AN2C5	5 Msps	T <sub>A</sub> = -20°C to 75°C	Commercial	24-Lead PDIP	1173AN2C5
TMC1173AN2C10	10 Msps	T <sub>A</sub> = -20°C to 75°C	Commercial	24-Lead PDIP	1173AN2C10
TMC1173AN2C20	20 Msps	T <sub>A</sub> = -20°C to 75°C	Commercial	24-Lead PDIP	1173AN2C20
TMC1173AR3C5	5 Msps	T <sub>A</sub> = -20°C to 75°C	Commercial	28-Lead PLCC	1173AR3C5
TMC1173AR3C10	10 Msps	T <sub>A</sub> = -20°C to 75°C	Commercial	28-Lead PLCC	1173AR3C10
TMC1173AR3C20	20 Msps	T <sub>A</sub> = -20°C to 75°C	Commercial	28-Lead PLCC	1173AR3C20
TMC1273M7C5	5 Msps	T <sub>A</sub> = -20°C to 75°C	Commercial	24-Lead SOIC	1273M7C5
TMC1273M7C10	10 Msps	T <sub>A</sub> = -20°C to 75°C	Commercial	24-Lead SOIC	1273M7C10
TMC1273M7C20	20 Msps	T <sub>A</sub> = -20°C to 75°C	Commercial	24-Lead SOIC	1273M7C20
TMC1273N2C5	5 Msps	T <sub>A</sub> = -20°C to 75°C	Commercial	24-Lead PDIP	1273N2C5
TMC1273N2C10	10 Msps	T <sub>A</sub> = -20°C to 75°C	Commercial	24-Lead PDIP	1273N2C10
TMC1273N2C20	20 Msps	T <sub>A</sub> = -20°C to 75°C	Commercial	24-Lead PDIP	1273N2C20
TMC1273R3C5	5 Msps	T <sub>A</sub> = -20°C to 75°C	Commercial	28-Lead PLCC	1273R3C5
TMC1273R3C10	10 Msps	T <sub>A</sub> = -20°C to 75°C	Commercial	28-Lead PLCC	1273R3C10
TMC1273R3C20	20 Msps	T <sub>A</sub> = -20°C to 75°C	Commercial	28-Lead PLCC	1273R3C20

Preliminary Information

### LIFE SUPPORT POLICY

FAIRCHILD'S PRODUCTS ARE NOT AUTHORIZED FOR USE AS CRITICAL COMPONENTS IN LIFE SUPPORT DEVICES OR SYSTEMS WITHOUT THE EXPRESS WRITTEN APPROVAL OF THE PRESIDENT OF FAIRCHILD SEMICONDUCTOR CORPORATION. As used herein:

1. Life support devices or systems are devices or systems which, (a) are intended for surgical implant into the body, or (b) support or sustain life, and (c) whose failure to perform when properly used in accordance with instructions for use provided in the labeling, can be reasonably expected to result in a significant injury of the user.
2. A critical component in any component of a life support device or system whose failure to perform can be reasonably expected to cause the failure of the life support device or system, or to affect its safety or effectiveness.