

# TMC2069P7C

## Demonstration Board for the TMC3003 DAC

### Features

- Parallel TTL Compatible Inputs
- Component and VGA Outputs
- Fairchild demo board compatibility

### Applications

- Evaluation of TMC3003 DAC
- Output for TMC2068P7C Decoder demo board
- Output for Genesis 10-bit Line doubler board
- System Breadboarding

### Description

The TMC2069P7C DAC demonstration board provides a flexible base for evaluating the performance of the TMC3003 triple 10 bit DAC.

The board can output analog component video or VGA. There are high quality Hybrid filters (601-003) on the output.

Preliminary Information

### Block Diagram

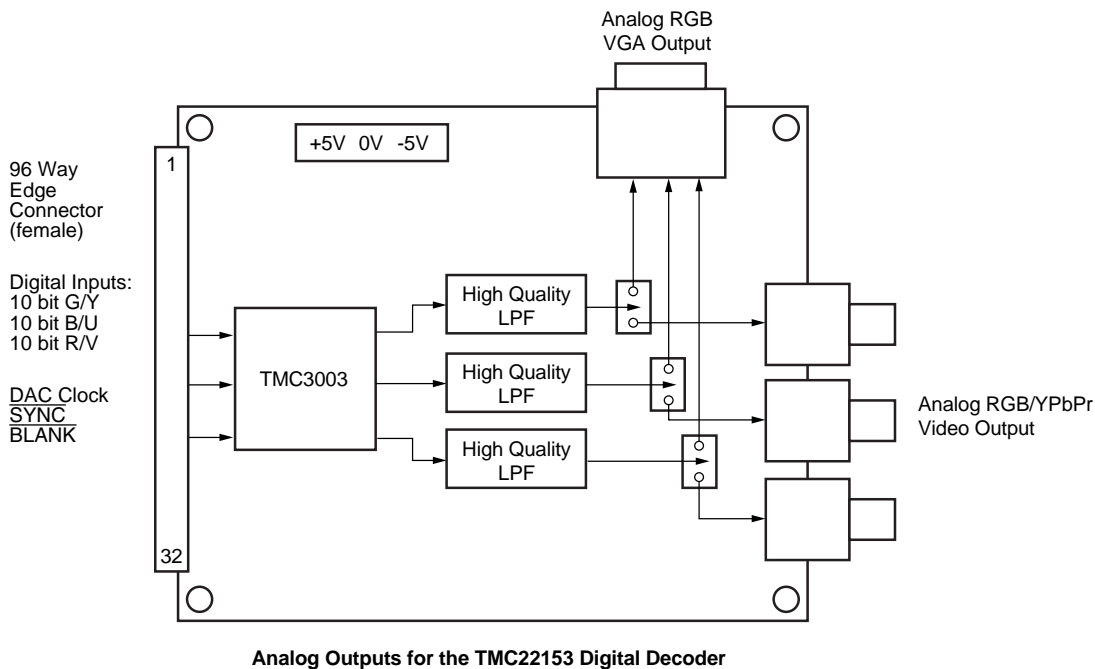

## Functional Description

The TMC2069P7C is designed to demonstrate the performance of the TMC3003 Digital to Analog converter. It also offers an example of design practices that result in high-quality video performance.

The TMC3003 is a high-speed triple 10-bit D/A converter especially suited for video and graphics applications. It offers 10-bit resolution, TTL-compatible inputs, low power consumption, and requires only a single +5 Volt power supply. It has single ended current output,  $\overline{\text{SYNC}}$  and  $\overline{\text{BLANK}}$  control inputs, and a separate current source for adding sync pulses to the Green D/A converter output. It is ideal for generating analog RGB from digital RGB and driving computer display and video monitors. Three speed grades are available: 30, 50, and 80 Msps.

The DAC module can be plugged into the TMC2068P7C decoder demonstration board to provide analog RGB or YPbPr outputs for viewing the decoder performance. The board can also be plugged into the 10-bit DICE line doubler demonstration board from Genesis. The input for the Genesis 10 bit line doubler board is being provided by the TMC2067P7C 10 bit ADC demonstration board connected to the TMC2068P7C decoder demonstration board.

A set of switches routes the triple DAC outputs to either the VGA connector or the component video connectors. The  $\overline{\text{SYNC}}$  and  $\overline{\text{BLANK}}$  signals to the triple DAC are required for the VGA mode are disabled when the component video output is required. The component video connectors provide sync on green.

## Setup Procedure

1. To set up the output levels on the triple dac, place a digital NTSC unmodulated ramp that has peak white at the digital level 824 and blanking at 240.
2. The output analog levels should be 286 mV sync tip to blank level and 1.0V sync tip to peak white. If the output levels are incorrect, adjust the GREEN output using the potentiometer RV1.
3. Apply either the unmodulated digital ramp used in step 1 to the red and blue inputs to adjust the Pb/BLUE and Pr/RED outputs or apply SMPTE color bars and measure the Pb and Pr outputs.
4. Adjust RV2, to adjust the RED, and RV3, to adjust the BLUE output.
  - a. If using the unmodulated ramp, match the output voltage levels to the values on the green channel.
  - b. If using the SMPTE color bars, the level of Pb and Pr peak to peak should be 525 mV.

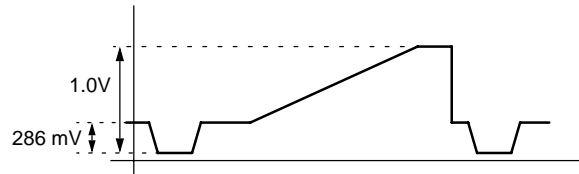

Figure 2. Unmodulated Ramp Waveform

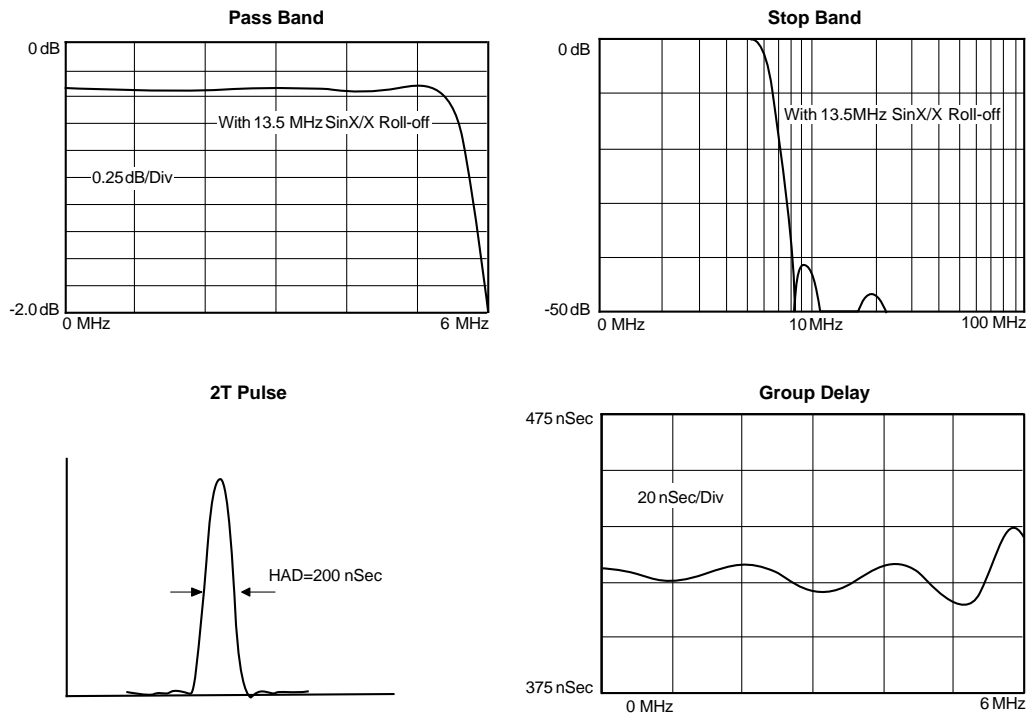

Figure 1. Output Low Pass Filters

## Power Supply Requirements

The TMC2069P7C board requires 1.5 Amps from the +5 Volt power supply and 0.5 Amps from the -5 Volt power supply. The -5 Volt power supply powers the SMA filters. The +5 Volt power supply not only drives TTL logic devices but it also provides the power and voltage references to the TMC3003. Therefore, it is recommended that a bench power supply be used with the cable lengths kept to a minimum.

## Output Low-Pass Filters

The 601-003 filters are high end broadcast quality filters. They are Virtual 601 post filters with a bandwidth of 5.75MHz. 5-pole, sharp cutoff, Elliptic response, with 3 sections of group delay equalization. These filters were designed for SinX/X compensated CCIR 601 luminance applications and make an excellent post-filter following a D/A converter.

The response at 5.0MHz typically varies  $\leq \pm 0.25$ dB with supplies of  $\pm 5$ V to  $\pm 8$ V. When operating in the 0dB gain mode, pin 6 must be well isolated from ground planes. When operating in the +6dB gain mode, pin 6 must have a low resistance path to ground.

For more information please contact Microelectronic Module Corporation (MMC) at 414-785-6506.

# Preliminary Information

## Schematics

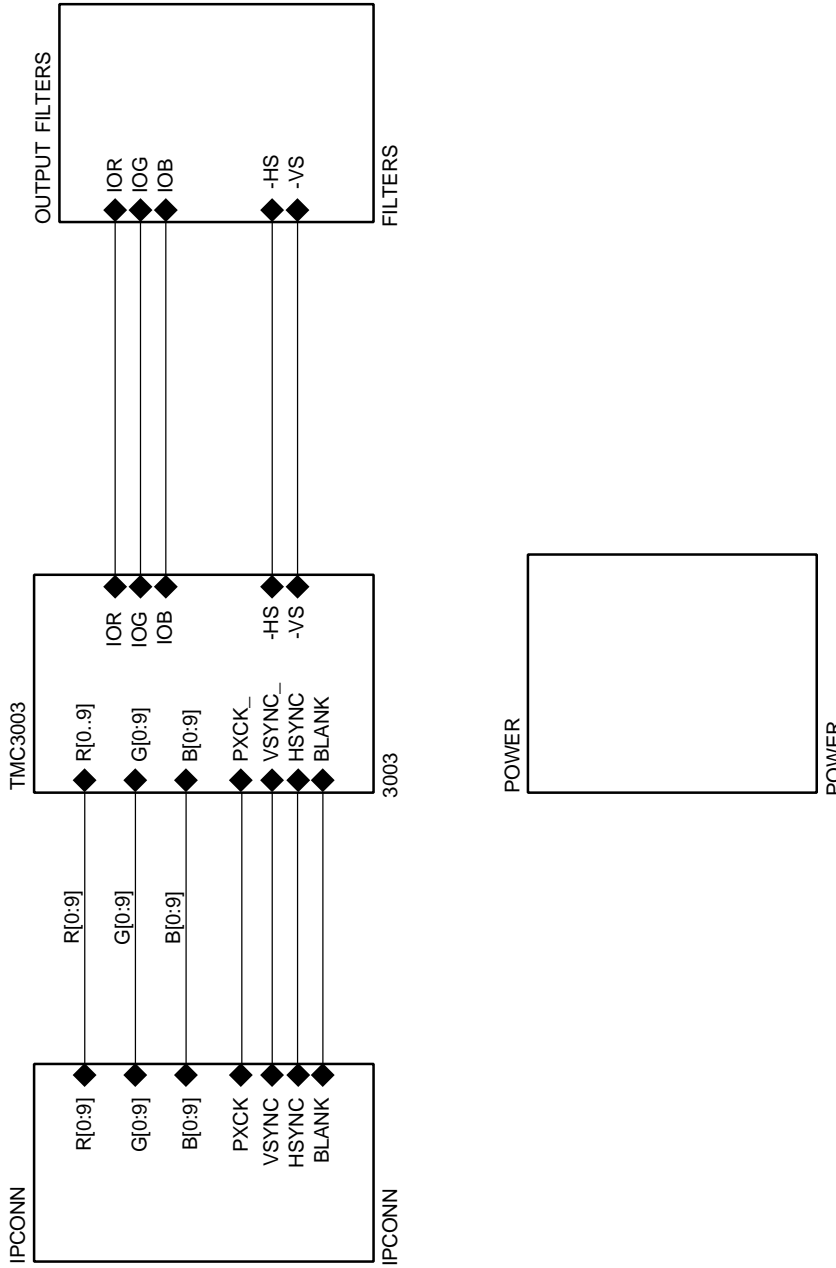

Figure 3. TMC2069P7C (10 Bit Triple DAC)

Schematics (continued)

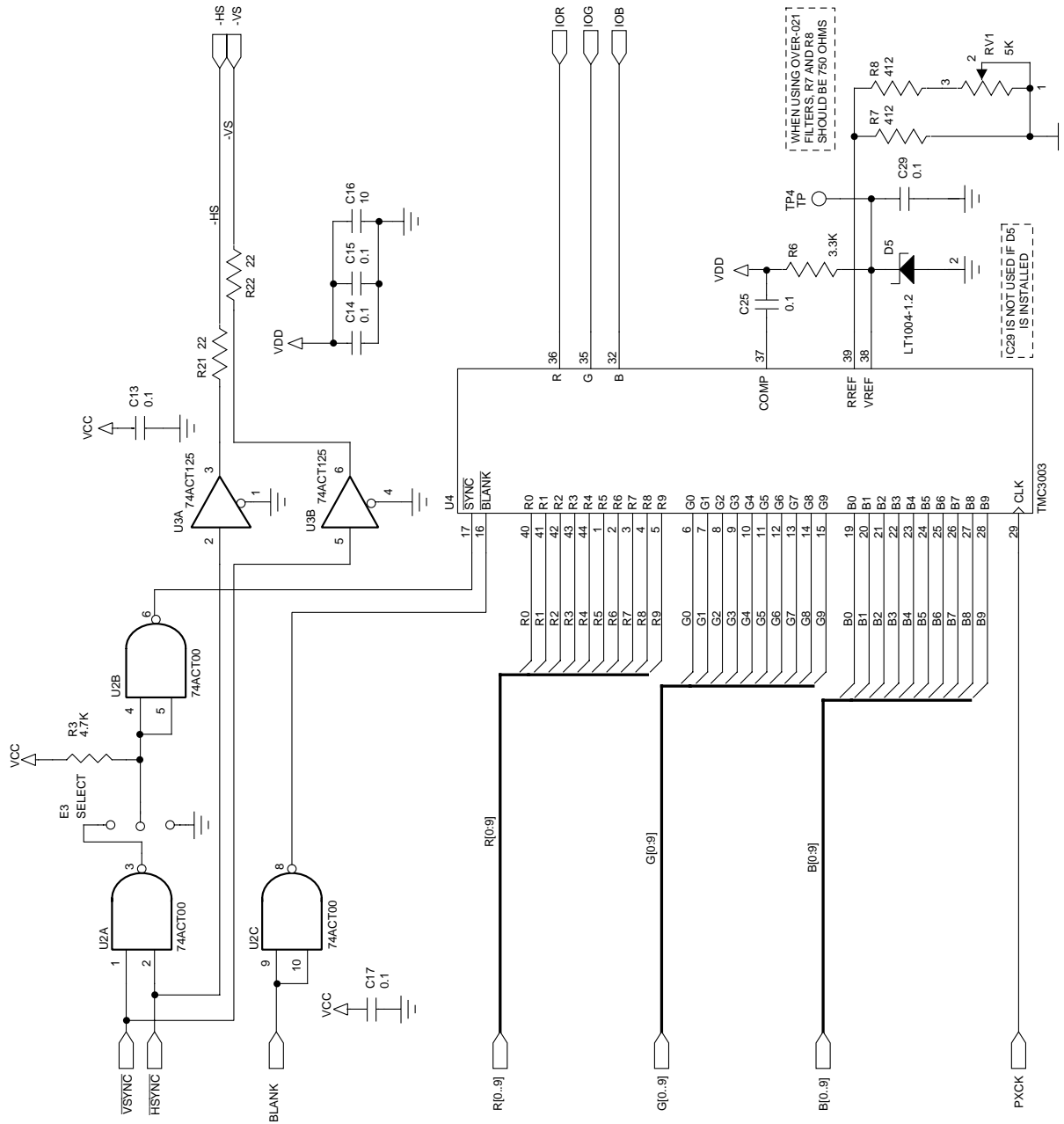

Figure 4. TMC3003, Passive Filters

Preliminary Information

Schematics (continued)

Preliminary Information

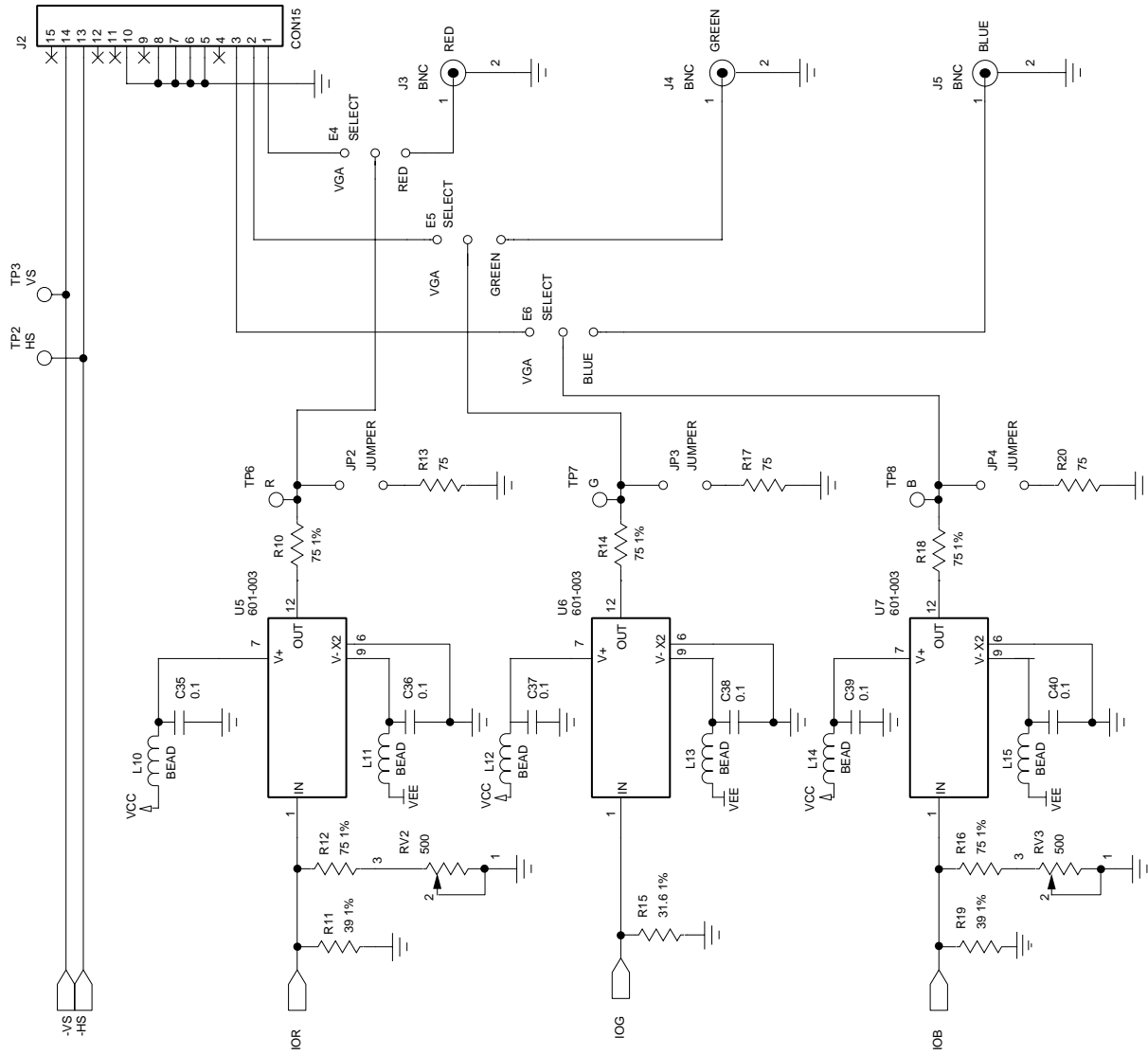

Figure 5. TMC2069P7C

Schematics (continued)

CONNECTOR "P1" IS A FEMALE CONNECTOR WHICH MATES WITH THE MALE CONNECTOR WITH THE PIN NUMBERS BEING FLIPPED. EXAMPLE: P1A PIN 1 MATES WITH THE MALE CONNECTOR PIN 32.

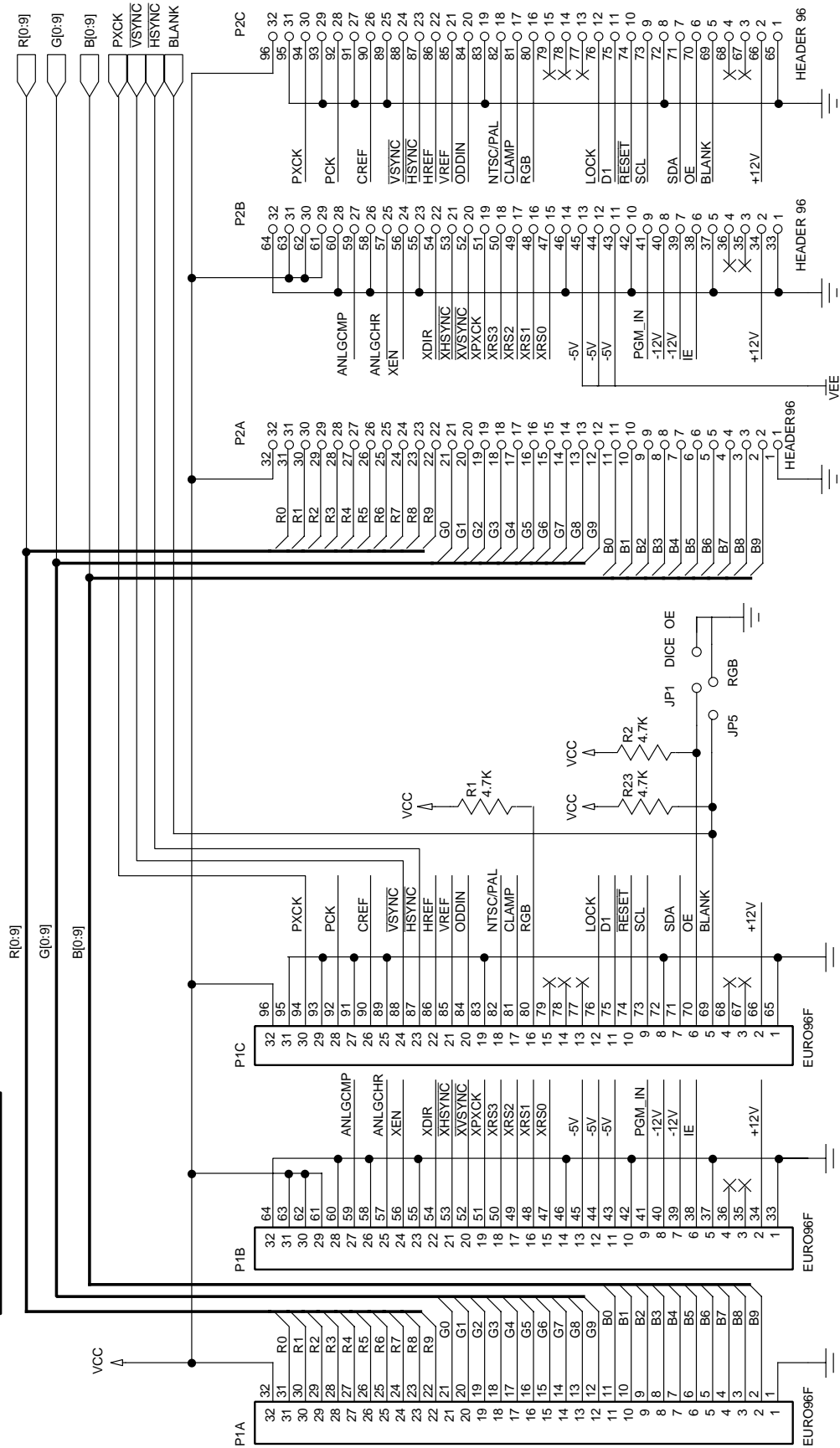

Figure 6. IPCONN

Preliminary Information

# Preliminary Information

## Schematics (continued)

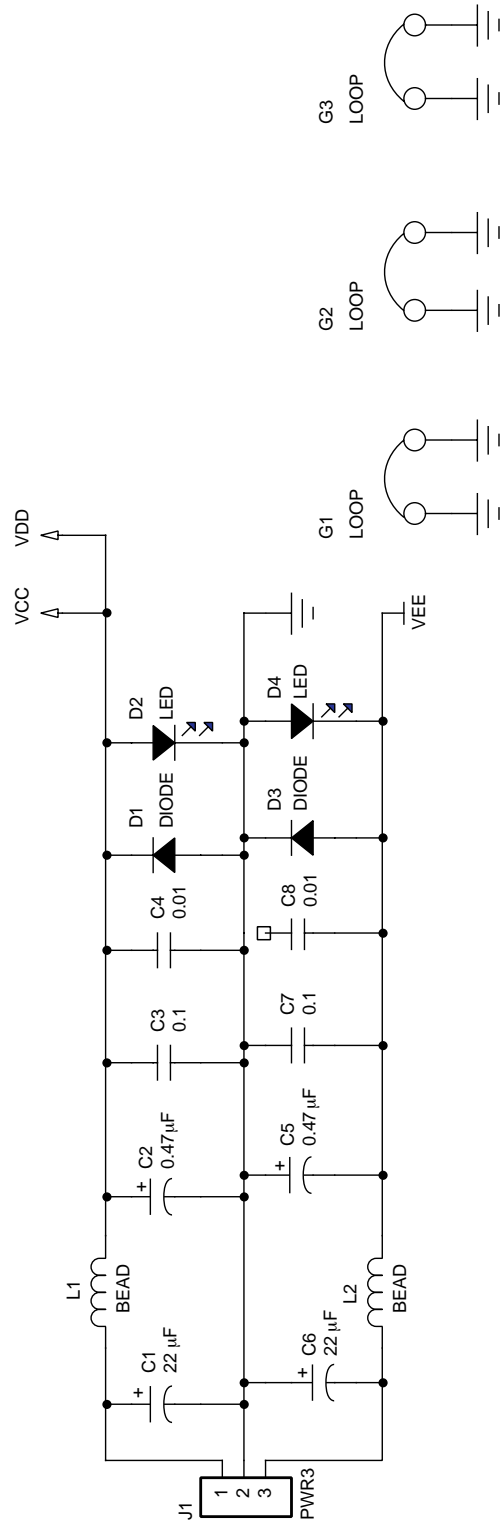

Figure 7. Power

Table 1. TMC2069P7C Parts List

Item	Qty.	Part Name	Reference Designator	Description
1	2	MiniReel: 645-823	C1,C6	22uf 25v Tantalum
2	2	MiniReel: 641-647	C2,C5	0.47 uf 25v Tantalum
3	1	MiniReel: 644-810	C16	10 uf 25v Tantalum
4	14	MiniReel: 605-611	C3,C7,C13,C14,C15,C17,C25,C29, C35,C36,C37,C38,C39,C40	0.1uF
5	2	MiniReel: 605-510	C4,C8	0.01 uf
6	2	MiniReel: 76-4004	D1,D3	FM4004, Diode
7	1	HP: h1mp-1600	D2	LED, Red 5v
8	1	HP: h1mp-1620	D4	LED, Yellow 5v
9	1	Linear Technology LT1004CH-1.235	D5	LT1004, 1.2
10	4	SECMA: 090320102	E3,E4,E5,E6	Subminiature switch, 2 pos. sip
11	3		G1,G2,G3	Wire Loop, gnd
12	5	AMP: 103747-2	JP1,JP2,JP3,JP4,JP5	Jumper, header
13	1	BEAU: 870503 BEAU: 871803	J1	Terminal block plug, and socket
14	1	AMP: 748390-5	J2	Con15, VGA
15	3	Amphenol: 31-5431	J3,J4,J5	BNC, Connector
16	8	Fair-Rite: 2743019447	L1,L2,L10,L11,L12,L13,L14,L15	Ferrite Bead
17	1	AMP: 650461-4	P1	EURO96F, Connector
18	1	AMP: 3-103817-0	P2	Header-96, 3x32
19	1	Bourns: 3262W502	RV1	5k ohm, pot.
20	2	Bourns: 3262W501	RV2,RV3	500 ohm, pot.
21	4	MiniReel: 615-848	R1,R2,R3,R23	4.7k ohm
22	1	MiniReel: 615-844	R6	3.3k ohm
23	1	MiniReel: 615-347	R7	475 ohm
24	1	MiniReel: 615-375	R8	750 ohm
25	5	MiniReel: 615-275	R10,R12,R14,R16,R18	75 ohm 1%
26	2	MiniReel: 615-809	R11,R19	39 ohm 1%
27	3	MiniReel: 655-275	R13,R17,R20	75 ohm
28	1	MiniReel: 615-231	R15	31.6 ohm 1%
29	2	MiniReel: 615-804	R21,R22	22 ohm
30	6	Mouser: ME151-203-100	TP2,TP3,TP4,TP6TP7,TP8	Test Points
31	1	Motorola: 74ACT00	U2	surface mount IC
32	1	Motorola: 74ACT125	U3	surface mount IC
33	1	Fairchild: TMC3003	U4	surface mount IC
34	3	601-003	U5,U6,U7	Active filters
35	2	CCI: B500-2-0.5-FO	Shield	Board stiffener used as a shield Special order part

Preliminary Information

**INPUT 96 Way Connector (Female)**

Row A		Row B		Row C	
32	+5V	32	GND	32	+5v
31	D1 or R/V [bit 0]	31	+5V	31	GND
30	D1 or R/V [bit 1]	30	+5V	30	PXCK
29	D1 or R/V [bit 2]	29	+5V	29	GND
28	D1 or R/V [bit 3]	28	GND	28	PCK
27	D1 or R/V [bit 4]	27	Analog Composite/luma	27	GND
26	D1 or R/V [bit 5]	26	GND	26	CREF
25	D1 or R/V [bit 6]	25	Analog chroma	25	GND
24	D1 or R/V [bit 7]	24	XEN	24	$\overline{\text{VSYNC}}$
23	D1 or R/V [bit 8]	23	GND	23	$\overline{\text{HSYNC}}$
22	D1 or R/V [bit 9]	22	XDIR	22	HREF
21	Comp, G/Y, or Luma [bit 0]	21	$\overline{\text{XHSYNC}}$	21	VREF
20	Comp, G/Y, or Luma [bit 1]	20	$\overline{\text{XVSYNC}}$	20	ODD IN
19	Comp, G/Y, or Luma [bit 2]	19	XPXCK	19	GND
18	Comp, G/Y, or Luma [bit 3]	18	XRS [bit 3]	18	NTSC/PAL
17	Comp, G/Y, or Luma [bit 4]	17	XRS [bit 2]	17	CLAMP pulse
16	Comp, G/Y, or Luma [bit 5]	16	XRS [bit 1]	16	RGB
15	Comp, G/Y, or Luma [bit 6]	15	XRS [bit 0]	15	
14	Comp, G/Y, or Luma [bit 7]	14	GND	14	
13	Comp, G/Y, or Luma [bit 8]	13	-5V	13	
12	Comp, G/Y, or Luma [bit 9]	12	-5V	12	LOCK
11	Chroma or B/U [bit 0]	11	-5V	11	D1
10	Chroma or B/U [bit 1]	10	GND	10	$\overline{\text{RESET}}$
9	Chroma or B/U [bit 2]	9	PGM_IN	9	SCL
8	Chroma or B/U [bit 3]	8	-12V	8	GND
7	Chroma or B/U [bit 4]	7	-12V	7	SDA
6	Chroma or B/U [bit 5]	6	IE (input enable)	6	OE (output enable)
5	Chroma or B/U [bit 6]	5	GND	5	$\overline{\text{BLANK}}$ (DAC)
4	Chroma or B/U [bit 7]	4		4	
3	Chroma or B/U [bit 8]	3		3	
2	Chroma or B/U [bit 9]	2	+12V	2	+12V
1	GND	1	GND	1	GND

Preliminary Information

## Input Edge Connector Design Notes

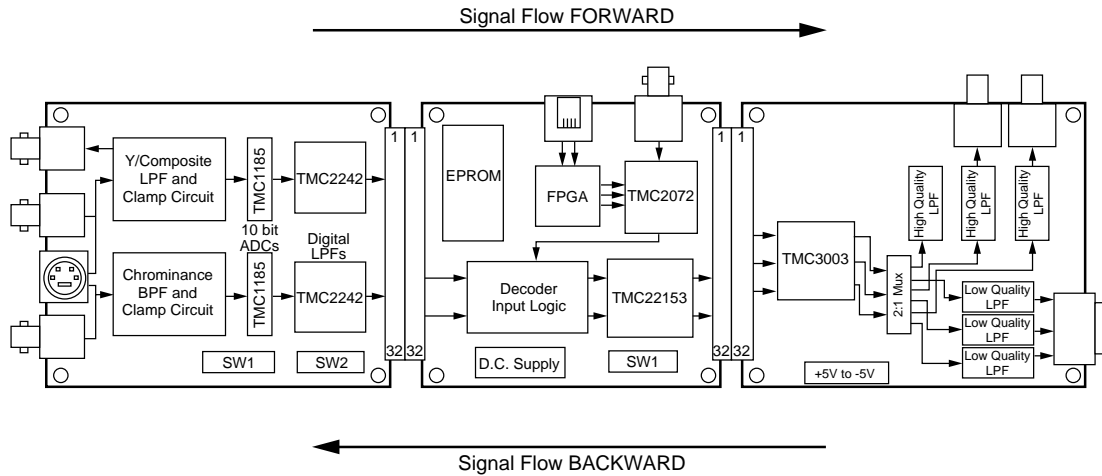

Figure 8.

### Important:

**Boards with different revision letters may not be compatible. Damage may occur if they are connected together!**

- XPXCK is a two times pixel clock fed BACKWARD.
- XHSYNC and XVSYNC are timing reference signals fed BACKWARD.
- The MASTER/SLAVE signal states if a board is a MASTER or a SLAVE board. This signal is fed FORWARD. A MASTER board produces the PXCK, HSYNC, and VSYNC signals, and a SLAVE board expects to receive XPXCK, XHSYNC, XVSYNC, etc .
- XDIR is fed FORWARD and controls in which direction the XRS[3:0] data flows.
- PGM\_IN is a negative going pulse, logically ANDed with the onboard program start pulse, for initiating the programming sequence for components on that board. Care must be taken to ensure that multiple devices do not try to drive the RBUS at any given time. Minimum width of PGM\_IN is 1uS.
- The RESET pin on the input edge connector should be connected directly to the RESET pin on the output connector. A link should be used to connect any pulse to the RESET line.
- The MASTER/SLAVE, XDIR, PGM\_IN and RESET pins on the input edge connector should be connected to +5V through a 10k pull up resistor.
- The CLAMP signal is fed BACKWARD from a MASTER to a SLAVE board. The CLAMP signal should not be fed FORWARD.

### Related Products

- TMC2068P7C Decoder demonstration board
- TMC2067P7C ADC demonstration board
- Raydemo software
- TMC2070P7C R-bus interface board

## Ordering Information

Product Number	Temperature Range	Speed Grade	Screening	Package	Package Marking
TMC2069P7C	25°C	80 MHz	Commercial	4" by 5" Printed Circuit Board	TMC2069P7C
TMC2069P7CG <sup>1</sup>	25°C	80 MHz	Commercial	4" by 5" Printed Circuit Board	TMC2069P7CG

### Notes:

1. Setup for use with Genesis 10-bit line doubler and comes with OVER-21 filters instead of 601-003 filters. For information call MMC at 414-785-6516. sales@mmccorp.com

A schematic database is available in OrCAD™ format. Contact the factory.

The TMC2069P7C Demonstration Board, design documentation, and software are provided as a design example for the customers of Fairchild. Fairchild makes no warranties, express, statutory, or implied regarding merchantability or fitness for a particular purpose.

## FCC Compliance

This device has not been approved by the Federal Communications Commission (FCC). This board is intended for the evaluation of Fairchild products only. This device is not and may not be offered for sale or lease or sold or leased until the approval of the FCC has been obtained.

Preliminary Information

### LIFE SUPPORT POLICY

FAIRCHILD'S PRODUCTS ARE NOT AUTHORIZED FOR USE AS CRITICAL COMPONENTS IN LIFE SUPPORT DEVICES OR SYSTEMS WITHOUT THE EXPRESS WRITTEN APPROVAL OF THE PRESIDENT OF FAIRCHILD SEMICONDUCTOR CORPORATION. As used herein:

1. Life support devices or systems are devices or systems which, (a) are intended for surgical implant into the body, or (b) support or sustain life, and (c) whose failure to perform when properly used in accordance with instructions for use provided in the labeling, can be reasonably expected to result in a significant injury of the user.
2. A critical component in any component of a life support device or system whose failure to perform can be reasonably expected to cause the failure of the life support device or system, or to affect its safety or effectiveness.