

TMC2070P7C

Parallel to RBUS Adapter

Features

- Parallel Input
- RBUS Output
- Fairchild demo board compatibility

Applications

- Evaluation of Fairchild demo boards
- System Breadboarding

Description

The TMC2070P7C RBUS adapter provides a simple interface between a computer parallel port and RBUS. It can be used with standard I2C drivers or the Fairchild Raydemo software.

This adapter requires a bi-directional parallel port. Power is supplied through the connectors. Be careful when using a parallel cable with this product. Some cables flip pins between the input and output connectors which may cause undesirable results.

Preliminary Information

Block Diagram

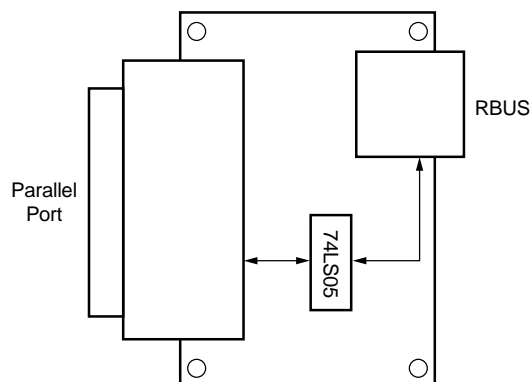

Table 1. TMC2070P7C Parts List

Item	Qty.	Part Name	Reference Designator	Description
1	1	MiniReel: 444-810	C1	10uf 16v
2	1	SN74LS05DN	U1	IC, 74LS05 surface mount
3	1	RS6A103G	RN1	10k ohm 6 pin Sip res.
4	1	AMP: 747842-4	P1	25 pin D Sub connector
5	1	Molex: 444-810	P2	ACCESS bus Plug

Preliminary Information

Schematic

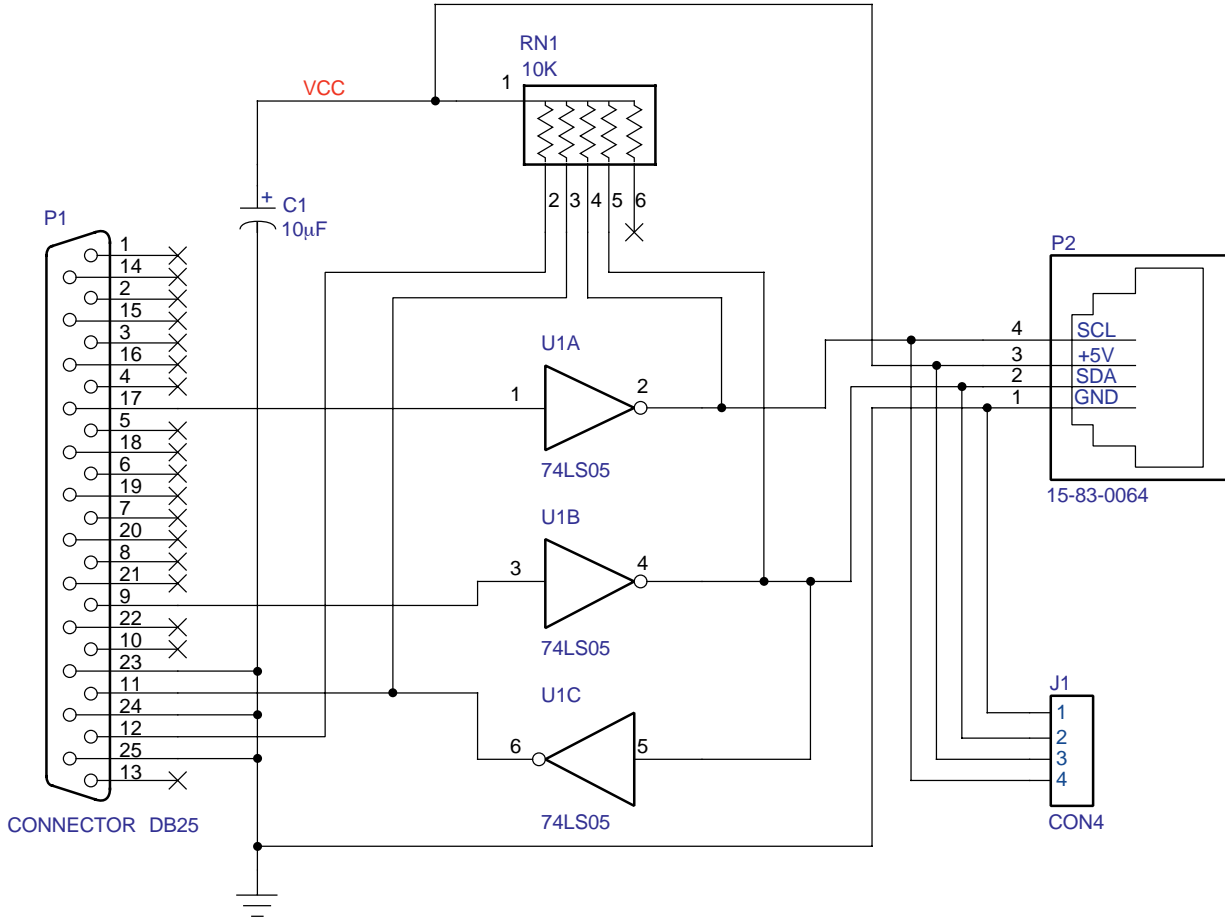

Figure 1. TMC2070P7C

Preliminary Information

Related Products

- TMC2068P7C Decoder demonstration board
- Raydemo software

Ordering Information

Product Number	Temperature Range	Speed Grade	Screening	Package	Package Marking
TMC2070P7C	25°C	100 KHz	Commercial	1" by 2" Printed Circuit Board	TMC2070P7C

A schematic database is available in OrCAD™ format. Contact the factory.

The TMC2070P7C Demonstration Board, design documentation, and software are provided as a design example for the customers of Fairchild. Fairchild makes no warranties, express, statutory, or implied regarding merchantability or fitness for a particular purpose.

All parameters contained in this specification are guaranteed by design, characterization, sample testing or 100% testing as appropriate. Fairchild reserves the right to change products and specifications without notice. This information does not convey any license under patent rights of Fairchild Company or others.

FCC Compliance

This device has not been approved by the Federal Communications Commission (FCC). This board is intended for the evaluation of Fairchild products only. This device is not and may not be offered for sale or lease or sold or leased until the approval of the FCC has been obtained.

Preliminary Information

LIFE SUPPORT POLICY

FAIRCHILD'S PRODUCTS ARE NOT AUTHORIZED FOR USE AS CRITICAL COMPONENTS IN LIFE SUPPORT DEVICES OR SYSTEMS WITHOUT THE EXPRESS WRITTEN APPROVAL OF THE PRESIDENT OF FAIRCHILD SEMICONDUCTOR CORPORATION. As used herein:

1. Life support devices or systems are devices or systems which, (a) are intended for surgical implant into the body, or (b) support or sustain life, and (c) whose failure to perform when properly used in accordance with instructions for use provided in the labeling, can be reasonably expected to result in a significant injury of the user.
2. A critical component in any component of a life support device or system whose failure to perform can be reasonably expected to cause the failure of the life support device or system, or to affect its safety or effectiveness.