

TMC22091/TMC22191

Digital Video Encoders/Layering Engine

Features

- All-digital video encoding
- Internal digital oscillators, no crystals required
- Multiple input formats supported
 - 24-bit and 15-bit GBR/RGB
 - YCbCr422 or 444
 - Color indexed
- 30 overlay colors (TMC22191)
- Fully programmable timing
- Supports input pixel rates of 10 to 15 Mpps
- 256 x 8 x 3 color look-up tables (bypassable on TMC22191)
- 8-bit mask register
- 8-bit composite digital video input
- Hardware and 24-bit data keying
- Synchronizes with TMC22071 Genlocking Video Digitizer
- 8:8:8 video reconstruction
- SMPTE 170M NTSC or CCIR Report 624 PAL compatible
- Supports PAL-M and NTSC without pedestal
- Simultaneous S-VIDEO (Y/C) NTSC/PAL output
- 10-bit D/A conversion (three channels)

- Controlled edge rates
- 3 power-down modes
- Built-in color bars and modulated ramp test signals
- JTAG (IEEE Std 1149.1-1990) test interface
- Single +5V power supply
- 84 lead PLCC package
- 100 lead MQFP package

Description

The TMC22x91 digital video encoders convert digital computer image or graphics data (in RGB, YCbCr, or color indexed format) or a CCIR-601 signal into a standard analog baseband television (NTSC or PAL) signal with a modulated color subcarrier.

Both composite (single lead) and S-VIDEO (separate chroma and luma) formats are active simultaneously at the three analog output pins, each of which generates a standard video-level signal into doubly-terminated 75Ω load.

The TMC22x91 accepts digitized video from the companion TMC22071 Genlocking Video Digitizer. Soft switching between video sources is done under either hardware or programmable data control.

The TMC22191 offers 4-layer keying capability, bypassable CLUT, and 30 Overlay colors.

The TMC22x91 is fabricated in a submicron CMOS process and packaged in an 84 Lead Plastic Leadless Chip Carrier, or in a 100 Lead Metric Quad Flat Pack. Performance is guaranteed from 0°C to 70°C.

Logic Symbol

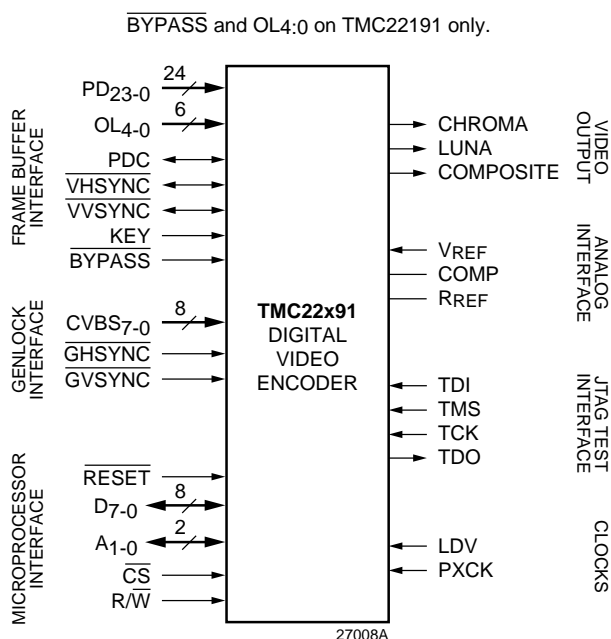

Block Diagram

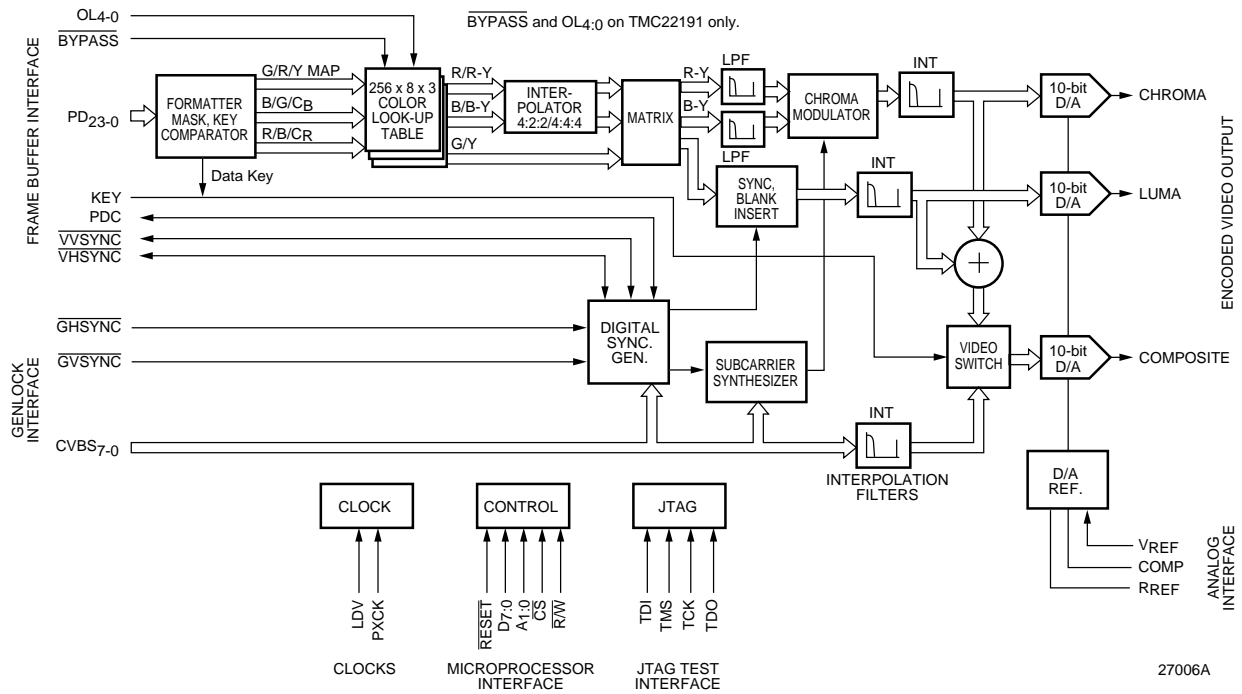

Functional Description

The TMC22091 and TMC22191 are totally integrated, fully-programmable digital video encoders with simultaneous composite and Y/C (S-VIDEO) outputs. The TMC22x91 video outputs are compatible with SMPTE 170M NTSC, CCIR Report 624 PAL, PAL-M, and NTSC without pedestal television standards. No external component selection or tuning is required.

The encoders accept digital image data at the PD port in one of several formats, which are matrixed into luminance and chrominance components. The chrominance signals are modulated onto a digitally synthesized subcarrier. The luminance and chrominance signals are separately interpolated to twice the pixel rate, and converted to analog levels by 10-bit D/A converters. They are also digitally combined and the resulting composite signal is output by a third 10-bit D/A converter. This composite signal may be keyed (pixel rate switching) with a second composite digital video signal presented to the encoder.

The output video frames may be internally timed by the TMC22x91, synchronized with the external frame buffer, or slaved to the companion Genlocking Video Digitizer (TMC22071). All operational parameters are fully programmable over a standard microprocessor port.

Table 1 shows the key features that distinguish between the TMC22091 and TMC22191. All of the information presented in this data sheet applies to both products unless otherwise noted. Statements, paragraphs, tables, and figures that apply to only one or two of the encoders have notation specifying the applicable part number.

Timing

The encoder operates from a single clock at twice the system pixel rate. This frequency may be set between 20 MHz and 36 MHz (pixel rates of 10 Mpps to 18 Mpps). Within this range are included CCIR-601, D2, and square-pixel formats, as well as a variety of computer-specific pixel rates. An array of programmable timing registers allows the software selection of all pertinent signal parameters to produce NTSC (with or without 7.5 IRE pedestal) and PAL, and PAL-M outputs.

Table 1. Comparing the TMC22x91 Encoders

Feature	TMC22091	TMC22191
OL4-0 pixel inputs for 30 overlay colors	No	Yes
Number of video layers supported	2	4
BYPASS input for bypassing CLUTs	No	Yes

Input Formatting

The input section accepts a variety of video and graphics formats, including 24-bit GBR and RGB, 15-bit GBR and RGB, YCBCR422, YCBCR444, and 8-bit color-indexed data (Figure 1a and 1b).

The input section of the TMC22x91 includes a key comparator which monitors the pixel data port with three independent 8-bit comparators, and invokes a video key when the selected registers match the incoming data.

Mask Register

A Mask Register is provided which is logically ANDed with incoming color-index data to facilitate pixel animation and other special graphics effects. The Mask Register is ahead of the Data Key comparators and is enabled only when color-index input is selected. Mask Register programming and operation are similar to that of the 171/176 family of graphics RAMDACs.

Color Lookup Table

The Color Lookup Table (CLUT) is a 256 x 8 x 3 random-access memory. It provides means for offset, gain, gamma, and color correction in RGB and YBCr operating modes. It provides a full 24-bit color lookup function for color-index mode. It can be loaded in the same manner as a standard VGA RAMDAC.

Colorspace Conversion Matrix and Interpolator

The matrix converts RGB data (whether from RGB inputs or color-indexed CLUT data) into Y, B-Y, R-Y format for encoding. In input configurations where the pixel input is already in Y, B-Y, R-Y format, the matrix is bypassed. When pixel data is input in YBCr422 format, the interpolation filters produce YBCr444 for encoding.

Sync Generator

The TMC22x91 can operate in Master, Genlock, or Slave modes. In Master and Genlock modes, the encoder internally generates all timing and sync signals, and provides Horizontal Sync, Vertical Sync, and Pixel Data Control (PDC) to the external frame buffer circuitry. PDC is independently selectable to function as an input or an output. In Genlock mode, the TMC22x91 timing is controlled by the TMC22071 Genlocking Video Digitizer over the CVBS7-0 bus, $\overline{GVS\text{Y}NC}$, and $\overline{GHS\text{Y}NC}$. The encoder, in turn, produces $\overline{VHS\text{Y}NC}$, $\overline{VVS\text{Y}NC}$, and PDC for the frame buffer interface.

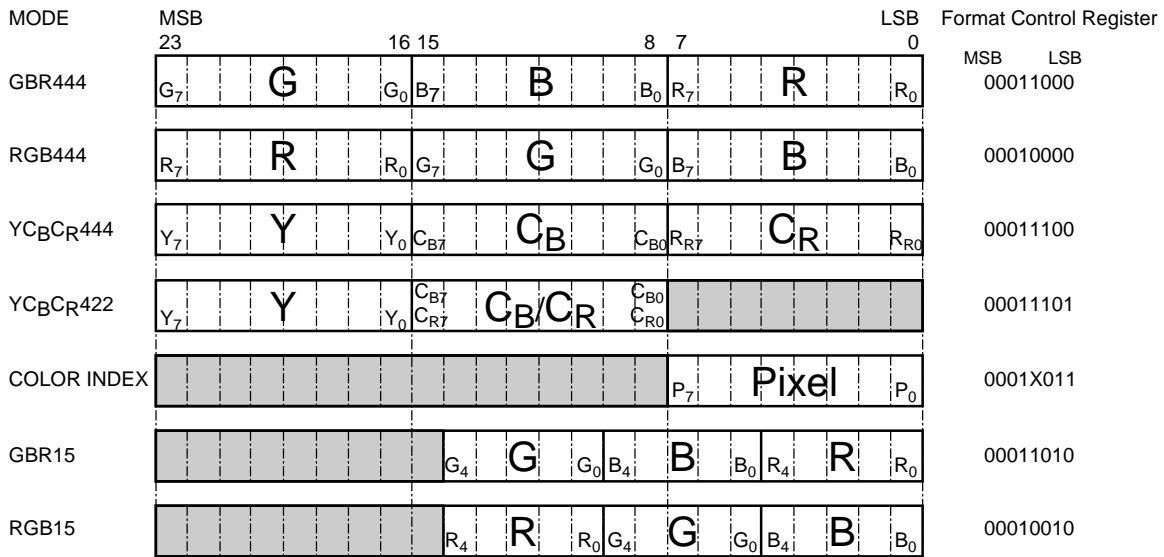

Figure 1a. Pixel Data Format

24300A

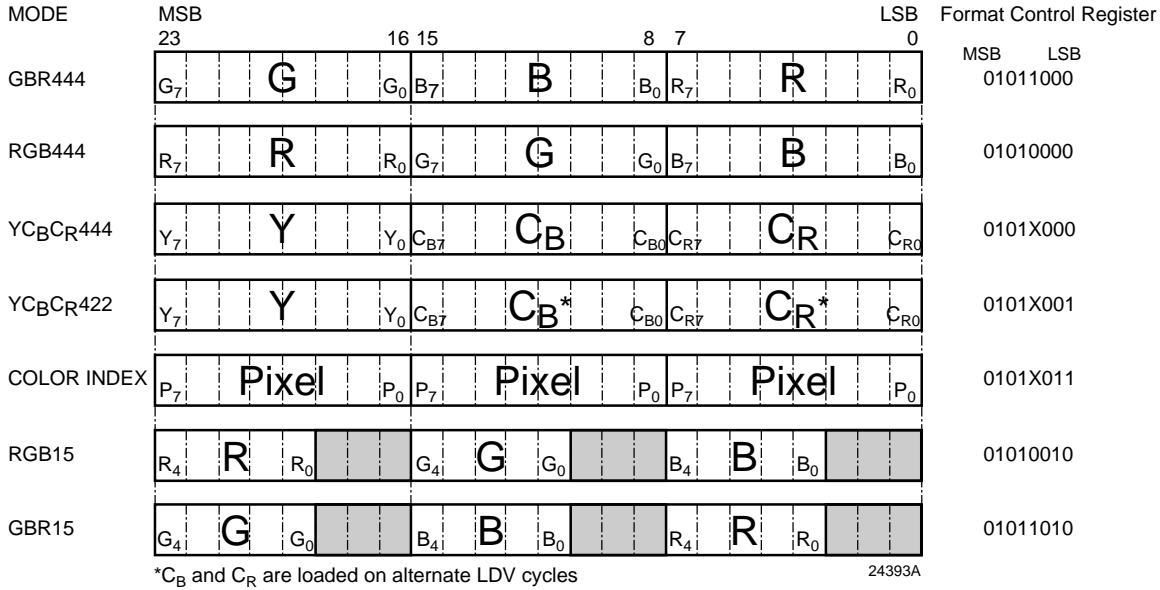

Figure 1b. Pixel Data Format (TMC22191 when CLUTs are Bypassed)

In Slave mode, $\overline{\text{VHSYNC}}$, $\overline{\text{VVSYNC}}$, and PDC (optional) are inputs to the TMC22x91. These inputs determine when new lines, frames, and active picture areas begin. The external controlling circuitry needs to establish the correct timing for these signals.

Horizontal and vertical synchronization signals are digitally generated by the TMC22x91 with controlled rise and fall times on all sync edges, the beginning and end of active video, and the burst envelope. All elements of horizontal sync timing are programmable, as are the frequency, phase, and duration of color burst.

Video Input

The TMC22x91 accepts genlocked synchronization data and digital composite video signals from the TMC22071 Genlocking Video Digitizer over the 8-bit CVBS bus. The encoder synchronizes its digital subcarrier oscillator to the video input from the TMC22071 with this data. The composite video data output from the TMC22071 is passed to the internal video switch for keying with the encoded pixel data.

Chroma Modulator

A 32-bit digital subcarrier synthesizer feeds a quadrature modulator, producing a digital chrominance signal. The relative phases of the burst and active video portions of the subcarrier can be individually adjusted to compensate for external phase errors and to effect a hue control.

Interpolation Filters

Interpolation filters on the luminance and chrominance signals double the pixel rate in preparation for D/A conversion. This band-limited process greatly simplifies the output filtering required following the D/A converters and dramatically reduces $\sin(x)/x$ distortion.

An interpolation filter on the CVBS data similarly raises the sample rate of the video signal, for mixing with the encoded pixel data.

Composite Video Switch

The Composite Video Switch selects between the composite video input (CVBS) and the composite encoded pixel data on a pixel-by-pixel basis, under the control of a key function.

Keying may be managed by hardware or software. The hardware key input (KEY pin) directly controls the video switch. The encoder may be programmed to operate with a data key, represented by three 8-bit registers that compare with the 24 input bits. They operate in all input modes and may be individually enabled or disabled.

D/A Converters

The analog outputs of the TMC22x91 are the outputs of three 10-bit D/A converters, operating at twice the pixel clock rate. The outputs are capable of driving standard video levels into a doubly-terminated 75Ω coaxial video cable (37.5Ω total load). An internal voltage reference is provided which can be used to provide reference current for the three D/A converters. For accurate video levels, an external fixed or variable voltage reference source is recommended. The video signal levels from the TMC22x91 may be adjusted to overcome the insertion loss of analog low-pass output filters.

The D/A converters on the TMC22x91 may be powered-down via Control Register 0E bits 5 and 6. The COMPOSITE D/A is controlled by bit 6 and the LUMA and CHROMA D/A converters are controlled by bit 5.

Microprocessor Interface

The microprocessor interface employs a 13 line format. The $\overline{\text{RESET}}$ pin sets all internal state machines to their initialized conditions, disables the analog outputs, sets the internal $\overline{\text{SRESET}}$ bit LOW (reset condition), and places the encoder in a power-down mode. All register and CLUT data are maintained in power-down mode. If the HRESET bit is set HIGH, line 1 field 1 is started when $\overline{\text{RESET}}$ goes HIGH, and $\overline{\text{SRESET}}$ is ignored. If HRESET is LOW, the encoder remains idle after $\overline{\text{RESET}}$ goes HIGH until Control Register bit $\overline{\text{SRESET}}$ is set HIGH, which initiates line 1 field 1.

Two address lines are provided and decoded for access to the internal Control Registers and CLUT. Control Registers and CLUT are accessed by loading a desired address through the 8-bit D7-0 port, followed by the desired data read or write for that address. Both the CLUT and the Control Registers are self-indexing, allowing continuous reads or writes to successive addresses.

JTAG Test Interface

The TMC22x91 includes a standard 4-line JTAG (IEEE Std 1149.1-1990) test interface port, providing access to all digital input/output data pins. This is provided to facilitate component and board-level testing.

Test/Validation Mode

The TMC22x91 may be configured to produce standard color bars or a 40 IRE modulated (or unmodulated) video ramp, independent of any pixel or video data input. Color

bars are useful as an idle system output signal. The test signals may be used to verify proper operation of the analog video signal chain.

TMC22090/TMC22190 Compatibility

The TMC22090 and TMC22190 are earlier versions of the TMC22091 and TMC22191, respectively. They lack the following features of the newer versions:

1. Selectable Setup (to support NTSC EIA-J video output for Japan)
2. PAL-M format (for South American applications)
3. Extended EH and SL intervals (to support pixel rates above 15 Mpps)
4. Individual D/A power-down (to reduce total dissipation when some outputs are not required)
5. Luminance I/O processing (to reduce flicker in graphics applications)

These features are controlled by registers 0E and 0F, and enabled by setting Register OE bit 7 to ONE. If an application of the TMC22x90 is programmed with this bit set to ZERO (as recommended in the product documentation) then the corresponding TMC22x91 will perform identically. Though the earlier parts continue to be available, it is recommended that the newer devices be used in new designs for the additional flexibility. Older designs may be readily converted to the newer versions to take advantage of the added features and lower cost of the later technology.

Pin Assignments

84 Lead PLCC

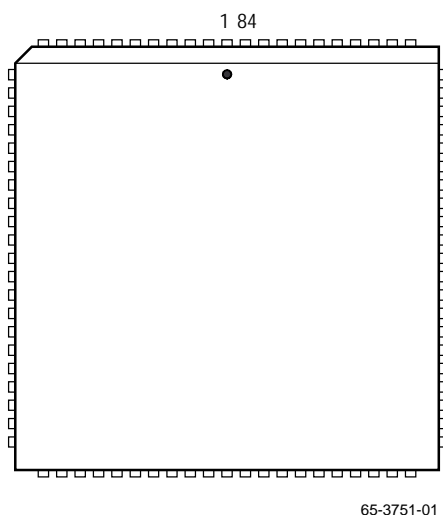

Pin	Name	Pin	Name	Pin	Name	Pin	Name
1	CVBS ₂	22	TDO	43	V _{DDA}	64	V _{DD}
2	CVBS ₁	23	TCK	44	CVBS ₇	65	D _{GND}
3	CVBS ₀	24	TMS	45	CVBS ₆	66	PD ₁₁
4	KEY	25	TDI	46	CVBS ₅	67	PD ₁₀
5	RESET	26	D _{GND}	47	CVBS ₄	68	PD ₉
6	CS	27	V _{DD}	48	OL ₃ (TEST)	69	PD ₈
7	R/W	28	BYPASS (TEST)	49	OL ₂ (TEST)	70	PD ₇
8	A ₁	29	OL ₄ (TEST)	50	OL ₁ (TEST)	71	PD ₆
9	A ₀	30	V _{REF}	51	OL ₀ (TEST)	72	PD ₅
10	D _{GND}	31	R _{REF}	52	PD ₂₃	73	PD ₄
11	PDC	32	A _{GND}	53	PD ₂₂	74	PD ₃
12	V _H SYNC	33	COMPOSITE	54	PD ₂₁	75	PD ₂
13	V _V SYNC	34	A _{GND}	55	PD ₂₀	76	PD ₁
14	D ₇	35	LUMA	56	PD ₁₉	77	PD ₀
15	D ₆	36	A _{GND}	57	PD ₁₈	78	LDV
16	D ₅	37	CHROMA	58	PD ₁₇	79	PXCK
17	D ₄	38	A _{GND}	59	PD ₁₆	80	D _{GND}
18	D ₃	39	COMP	60	PD ₁₅	81	V _{DD}
19	D ₂	40	V _{DDA}	61	PD ₁₄	82	G _V SYNC
20	D ₁	41	V _{DDA}	62	PD ₁₃	83	G _H SYNC
21	D ₀	42	V _{DDA}	63	PD ₁₂	84	CVBS ₃

Note: Pin names in parentheses apply to TMC22091.

100 Lead MQFP

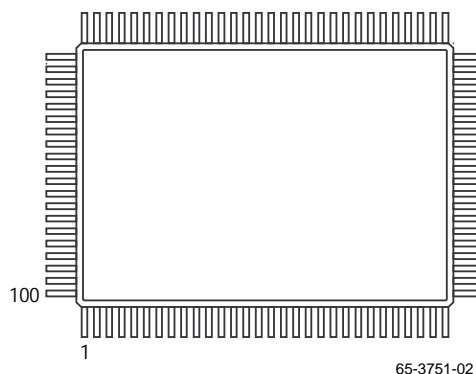

Pin	Name	Pin	Name	Pin	Name	Pin	Name
1	NC	26	PD ₂₃	51	PD ₃	76	D _{GND}
2	COMPOSITE	27	PD ₂₂	52	NC	77	PDC
3	NC	28	NC	53	NC	78	NC
4	A _{GND}	29	NC	54	NC	79	NC
5	LUMA	30	NC	55	NC	80	V _H SYNC
6	A _{GND}	31	PD ₂₁	56	PD ₂	81	V _V SYNC
7	NC	32	PD ₂₀	57	PD ₁	82	D ₇
8	CHROMA	33	PD ₁₉	58	PD ₀	83	D ₆
9	A _{GND}	34	PD ₁₈	59	LDV	84	D ₅
10	COMP	35	PD ₁₇	60	PXCK	85	D ₄
11	NC	36	PD ₁₆	61	D _{GND}	86	D ₃
12	NC	37	PD ₁₅	62	V _{DD}	87	D ₂
13	V _{DDA}	38	PD ₁₄	63	G _V SYNC	88	D ₁
14	V _{DDA}	39	PD ₁₃	64	G _H SYNC	89	D ₀
15	V _{DDA}	40	PD ₁₂	65	CVBS ₃	90	TDO
16	V _{DDA}	41	V _{DD}	66	CVBS ₂	91	TCK
17	V _{DDA}	42	D _{GND}	67	CVBS ₁	92	TMS
18	CVBS ₇	43	PD ₁₁	68	CVBS ₀	93	TDI
19	CVBS ₆	44	PD ₁₀	69	NC	94	D _{GND}
20	CVBS ₅	45	PD ₉	70	KEY	95	V _{DD}
21	CVBS ₄	46	PD ₈	71	RESET	96	BYPASS (TEST)
22	OL ₃ (TEST)	47	PD ₇	72	CS	97	OL ₄ (TEST)
23	OL ₂ (TEST)	48	PD ₆	73	R/W	98	V _{REF}
24	OL ₁ (TEST)	49	PD ₅	74	A ₁	99	R _{REF}
25	OL ₀ (TEST)	50	PD ₄	75	A ₀	100	A _{GND}

Note: Pin names in parentheses apply to TMC22091.

Pin Descriptions

Pin Name	Pin Number		Value	Pin Function Description
	84-Lead PLCC	100-Lead MQFP		
Clocks				
PXCK	79	60	TTL	Master Clock Input. This 20 to 30 MHz clock is internally divided by 2 to generate the internal pixel clock, PCK, which a LOW on $\overline{\text{RESET}}$ forces LOW. PXCK drives the entire TMC22x91, except the asynchronous microprocessor interface and the semi-synchronous LDV data input clock. All internal registers are strobed on the rising edge of PXCK.
LDV	78	59	TTL	Pixel Data Load Clock. On each rising edge of LDV, data on PD ₂₃₋₀ are latched into the input preload register, for transfer into the input demultiplexer on the next rising edge of PCK.
Frame Buffer Interface				
PD ₂₃₋₀	52-63, 66-77	26, 27, 31-40, 43-51, 56-58	TTL	Pixel Data Inputs. In YCbCr, GBR, RGB, and color-indexed mode, pixel data enter the TMC22x91 on PD ₂₃₋₀ . The specific format is found in Figures 1a and 1b. LDV is the clock that controls the loading of pixel data.
$\overline{\text{VHSYNC}}$	12	80	TTL	Horizontal Sync I/O. In Master and Genlock modes, the TMC22x91 outputs horizontal sync on this pin. In Slave modes, the TMC22x91 accepts and locks to horizontal sync input on this pin (with vertical sync on $\overline{\text{VVSYN}}\overline{\text{C}}$). $\overline{\text{VHSYN}}\overline{\text{C}}$ and $\overline{\text{VVSYN}}\overline{\text{C}}$ must be coincident since they are clocked into the TMC22x91 on the same rising edge of PXCK.
$\overline{\text{VVSYN}}\overline{\text{C}}$	13	81	TTL	Vertical Sync I/O. In separate V and H sync Master and Genlock modes, the TMC22x91 outputs vertical block sync ($\overline{\text{VVSYN}}\overline{\text{C}}$ LOW for the 2.5 (PAL) or 3 (NTSC) lines on which vertical sync pulses occur). In composite sync (H and V sync on same signal) Master and Genlock modes, the TMC22x91 outputs horizontal sync, vertical sync, and equalization over this pin. In Slave mode, the TMC22x91 accepts and locks to vertical sync input on this pin (with horizontal sync on $\overline{\text{VHSYN}}\overline{\text{C}}$). $\overline{\text{VHSYN}}\overline{\text{C}}$ and $\overline{\text{VVSYN}}\overline{\text{C}}$ must be coincident such that they are clocked into the TMC22x91 on the same rising edge of PXCK.
PDC	11	77	TTL	Pixel Data Control. In Master mode, the TMC22x91 forces PDC HIGH when and only when it wants active video from the frame buffer. During blanking (syncs, equalization, burst, and porches), it forces PDC LOW, signaling that it will ignore any data presented over PD ₂₃₋₀ . When PDC is used as an input, forcing it HIGH allows the TMC22x91 to receive PD during the active video state.
KEY	4	70	TTL	Hardware Key Input. When the HKEN control bit is set HIGH and hardware key pin, KEY, is HIGH, video data entering on CVBS ₇₋₀ are routed to the COMPOSITE output. This control signal is pipelined so the pixel that is presented to the PD port when the KEY signal is invoked is at the midpoint of the soft key transition. When HKEN is LOW, KEY is ignored. Like PD data, KEY is clocked into the TMC22x91 on the rising edge of LDV.

Pin Descriptions (continued)

Pin Name	Pin Number		Value	Pin Function Description
	84-Lead PLCC	100-Lead MQFP		
OL4-0	29, 48-51	97, 22-25	TTL	Overlay Data Inputs (TMC22191 only). 30 of the 256 locations of the CLUT may be reserved for overlay operation. These CLUT locations are directly accessed by five input pins, OL4-0. OL4-0 are entered into the TMC22191 on a pixel-by-pixel basis and select which of the 30 overlay colors is to be encoded. When all five OL4-0 inputs are LOW, no overlay occurs.
BYPASS	28	96	TTL	CLUT Bypass Control (TMC22191 only). When $\overline{\text{BYPASS}}$ is HIGH, the CLUT is in the pixel data path within the TMC22191. When $\overline{\text{BYPASS}}$ is LOW, pixel data bypasses the CLUT. $\overline{\text{BYPASS}}$ is active only for certain modes of the Layering Control Register (LCR) when the Format Control Register bit 6 is HIGH.
Genlock Interface				
$\overline{\text{GHSYNC}}$	83	64	CMOS	Genlock Horizontal Sync. In Genlock mode, the TMC22x91 will start a new horizontal line (blank-to-sync-edge transition) with each falling edge of $\overline{\text{GHSYNC}}$. In non-genlock modes, the TMC22x91 ignores $\overline{\text{GHSYNC}}$. The internal pixel clock, PCK, is aligned with the falling edge of $\overline{\text{VHSYNC}}$ or $\overline{\text{GHSYNC}}$ (Genlock mode).
$\overline{\text{GVSYNC}}$	82	63	CMOS	Genlock Vertical Sync. In Genlock mode, the TMC22x91 will start a new vertical sync sequence at line 1 field 1 whenever $\overline{\text{GVSYNC}}$ and $\overline{\text{GHSYNC}}$ are coincident such that they are clocked into the TMC22x91 on the same rising edge of PCK. If $\overline{\text{GVSYNC}}$ falls at any other time, the TMC22x91 will assume that this marks the start of field 2, and will ignore it (in odd-field sync mode) or (in all-field sync mode) respond by generating a single vertical sync pulse, followed by 2 (PAL) or 2.5 (NTSC) lines of vertical sync, keyed to the next falling edge on $\overline{\text{GHSYNC}}$. See Interface Control Register bit 0 for odd-field and all-field operation.
CVBS7-0	44-47, 84, 1-3	18-21, 65-68	TTL	Composite Video Inputs. The encoder receives digitized video, subcarrier phase, and subcarrier frequency over this 8-bit bus at the PCK rate. This data may be provided by the companion TMC22071 Genlocking Video Digitizer. In Genlock mode, the TMC22x91 expects subcarrier phase and frequency data during each line's horizontal sync interval, as well as video data when keying is engaged, transferred at the PCK rate.
Microprocessor Interface				
D7-0	14-21	82-89	TTL	Data I/O Port. All control parameters are loaded into and read back over this 8-bit port. For digital testing, the five lower bits can also serve as a two-cycle 10-bit data output port. For D/A converter testing, it can be used as a 10-bit two-cycle input port, facilitating, for example, ramp-based D/A converter linearity tests.
A1-0	8-9	74-75	TTL	μProc Port Controls. As in a RAMDAC, this control governs whether the microprocessor interface selects a table address or reads/writes table contents. It also governs setting and verification of the TMC22x91's internal operating modes, also over port D7-0.

Pin Descriptions (continued)

Pin Name	Pin Number		Value	Pin Function Description
	84-Lead PLCC	100-Lead MQFP		
\overline{CS}	6	72	TTL	Chip Select. When \overline{CS} is HIGH, the microprocessor interface port, D7-0, is set to HIGH impedance and ignored. When \overline{CS} is LOW, the microprocessor can read or write parameters over D7-0. One additional falling edge of \overline{CS} is needed to move input data to its assigned working registers.
R/\overline{W}	7	73	TTL	Bus Read/Write Control. When R/\overline{W} and \overline{CS} are LOW, the microprocessor can write to the control registers or CLUT over D7-0. When R/\overline{W} is HIGH and \overline{CS} is LOW, it can read the contents of any CLUT address or control register over D7-0.
\overline{RESET}	5	71	TTL	Master Reset Input. Bringing \overline{RESET} LOW sets the software reset control bit, \overline{SRESET} , LOW, forcing the internal state machines to their starting states and disabling all outputs. Bringing \overline{RESET} HIGH synchronizes the internal pixel clock ($PCK = PXCK / 2$) to maintain a defined pipeline delay through the TMC22x91. If HRESET is set HIGH, the encoder is enabled when \overline{RESET} goes HIGH. If HRESET is LOW, the host restarts the TMC22x91 by setting \overline{SRESET} HIGH. \overline{RESET} does not affect the CLUT or the control registers, except \overline{SRESET} .
Video Output				
COMPOSITE	33	2	1 V P-P	NTSC/PAL Video. Analog output of composite D/A converter, nominally 1.35 volt peak-to-peak into a 37.5 Ω load.
LUMA	35	5	1 V P-P	Luminance-only Video. Analog output of luminance D/A converter, nominally 1.35 volt peak-to-peak into a 37.5 Ω load.
CHROMA	37	8	1 V P-P	Chrominance-only Video. Analog output of chrominance D/A converter, nominally 1.35 volt peak-to-peak into a 37.5 Ω load.
Analog Interface				
VREF	30	98	+1.23 V	Voltage Reference Input. External voltage reference input, internal voltage reference output, nominally 1.235 V.
COMP	39	10	0.1 μ F	Compensation Capacitor. Connection point for 0.1 μ f decoupling capacitor.
RREF	31	99	392 Ω	Current-setting Resistor. Connection point for external current-setting resistor for D/A converters. The resistor (392 Ω) is connected between RREF and AGND. Output video levels are inversely proportional to the value of RREF.
JTAG Test Interface				
TDI	25	93	TTL	Data Input Port. Boundary scan data input port.
TMS	24	92	TTL	Scan Select Input. Boundary scan (HIGH)/normal operation (LOW) selector.
TCK	23	91	TTL	Scan Clock Input. Boundary scan clock.
TDO	22	90	TTL	Data Output Port. Boundary scan data output port.
Power Supply				
VDD	27, 64, 81	41, 62, 95	+5 V	Positive digital power supply.
VDDA	40-43	13-17	+5 V	Positive analog power supply.
DGND	10, 26, 65, 80	42, 61, 76, 94	0.0 V	Digital Ground.
AGND	32, 34, 36, 38	4, 6, 9, 100	0.0 V	Analog Ground.

Pin Descriptions (continued)

Pin Name	Pin Number		Value	Pin Function Description
	84-Lead PLCC	100-Lead MQFP		
Test				
TEST	28, 29, 48-51	22-25, 96-97	0.0 V	Factory testing (TMC22091 only). Reserved for factory testing. These pins have no effect on the operation but do function as JTAG registers. They should be grounded directly or pulled down to ground with 1k Ω or smaller resistors.
NC	N/A	1, 3, 7, 11-12, 28-30, 52-55, 69, 78-79		No Connect

Control Registers

The TMC22x91 is initialized and controlled by a set of registers. The registers are organized into 13 categories:

1. Global Control
2. Format Control
3. Interface Control
4. Test Control
5. Key Control
6. Misc. Control
7. Standards Control
8. Layering Control (TMC22191)
9. Key Value
10. Timing
11. Subcarrier
12. Test I/O
13. Mask Register

An external controller loads the Control Registers through a standard interface port. It also loads the CLUT and reads its

contents or those of the Control Registers. The port is governed by pins \overline{CS} , R/\overline{W} , and A1-0.

The Address Register for the CLUT and the Control Register pointer automatically increment to allow successive writes to sequential addresses. In the CLUT, the Address Register has two additional bits which increment in modulo-three to sequentially access the red, green, and blue portions. All three colors must be written when any CLUT address is changed.

The control register autoincrement follows the sequence indicated in the Control Register Map. When it reaches address 40, it stops incrementing, allowing multiple reads or writes of test data from/to the TESTDAT register. To exit the test mode, reset the Control Register pointer by setting A1-0, D7-0, and R/\overline{W} LOW and then bring \overline{CS} LOW. Address 1F is a read-only status register. It is addressed by the autoincrement sequencer. Any data may be written into this port at that time but it will not be stored. When address 50 is accessed, no autoincrement takes place, allowing multiple writes to the Mask Register.

Table 2. Microprocessor Port Control

A1-0	R/W	Action
00	0	Write D7-0 into Control Register pointer
00	1	Read Control Register pointer on D7-0
01	0	Write D7-0 into CLUT Address Pointer
01	1	Read CLUT Address Pointer on D7-0
10	0	Write D7-0 to addressed Control Register
10	1	Read addressed Control Register on D7-0
11	0	Write D7-0 to addressed CLUT location
11	1	Read addressed CLUT location on D7-0

Table 3. Control Register Map

Reg	Bit	Name	Function
Global Control Register			
00	7-5		Reserved
00	4	$\overline{\text{SRESET}}$	Software reset
00	3	PAL	Standard select, NTSC or PAL
00	2	LUMDIS	Luminance input disable
00	1	CHRDIS	Chrominance input disable
00	0	HRESET	Software reset disable
Format Control Register			
01	7		Reserved
01	6	LCREN	Layering Control Register enable (TMC22191)
01	5	RAMPEN	Modulated ramp test
01	4	$\overline{\text{CB}}$	Color bar test
01	3-2	FORMAT	PD23-0 input format select
01	1-0	INMODE	PD23-0 input mode select
Interface Control Register			
02	7	VITSEN	VITS lines enable
02	6	SHCY	Short-cycle test mode
02	5-4	TBASE	Time-base source select
02	3	SOUT	Sync output mode select

Table 3. Control Register Map (continued)

Reg	Bit	Name	Function
02	2	FBDIS	Frame buffer signals disable
02	1	PDCDIR	PDC master, slave select
02	0	FLDLK	Field lock select
Test Control Register			
03	7		Reserved
03	6	LIMEN	Luminance limiter enable
03	5	TESTEN	Test enable
03	4	HOLDEN	MSBs/LSBs hold select
03	3	TSTMSB	LSBs, MSBs in/out select
03	2	LUMTST	LUMA channel test
03	1	8FSUBR	8-field subcarrier reset enable
03	0	CHRTST	CHROMA channel test
Key Control Register			
04	7		Reserved
04	6	HKEN	Hardware key enable
04	5	BUKEN	Burst key enable
04	4	SKEXT	Data key operation select
04	3	DKDIS	Green/red/Y data key disable
04	2	EKDIS	Blue/green/CB data key disable
04	1	FKDIS	Red/blue/C _R data key disable
04	0	SKEN	Data key enable
Layering Control Register (TMC22191)			
04	7	LAYMODE	MSB of Layer Assignments select
04	6	HKEN	Hardware key enable
04	5	BUKEN	Burst key enable
04	4	SKEXT	Data key operation select
04	3-1	LAYMODE	LSBs of Layer Assignments select
04	0	SKEN	Data key enable
Key Value Registers			
05	7-0	DKEY	Green/red/Y data key value
06	7-0	EKEY	Blue/green/CB data key value

Table 3. Control Register Map (continued)

Reg	Bit	Name	Function
07	7-0	FKEY	Red/blue/CR data key value
08-0D			Reserved
Misc. Control Register			
0E	7	EFEN	Register 0E and 0F enable
0E	6	COMPDA	COMPOSITE D/A disable
0E	5	SVIDD/A	LUMA/CHROMA D/A disable
0E	4	FKREN	Luminance processing enabled
0E	3	RATIO	Luminance ratio select
0E	2	TFLK	Luminance pass threshold select
0E	1	T512	EH/SL offset select
0E	0	CB100	NTSC/PAL Color Bars
Standards Control Register			
0F	7	EFEN	Same as Reg 0E bit 7 but read-only
0F	6	SIX25	625/525 line per frame select
0F	5	PALID	Phase alternate line select
0F	4	SETUP	7.5 IRE Pedestal Enable
0F	3-2	YGAIN	Luminance gain settings
0F	1-0	CGAIN	Chrominance gain settings
Timing Registers			
10	7-0	SY	Horizontal sync tip length
11	7-0	BR	Breezeway length
12	7-0	BU	Burst length
13	7-0	CBP	Color back porch length
14	7-0	XBP	Extended color back porch 8 LSB
15	7-0	VA	Active video 8 LSB
16	7-0	VC	Active video start 8 LSB
17	7-0	VB	Active video end 8 LSB
18	7-6	XBP	Extended color back porch 2 MSB
18	5-4	VA	Active video 2 MSB
18	3-2	VC	Active video start 2 MSB
18	1-0	VB	Active video end 2 MSB

Table 3. Control Register Map (continued)

Reg	Bit	Name	Function
19	7-0	FP	Front porch length
1A	7-0	EL	Equalization pulse LOW length
1B	7-0	EH	Equalization pulse HIGH length
1C	7-0	SL	Vertical sync LOW length
1D	7-0	SH	Vertical sync HIGH length
1E	7-0	CBL	Color bar length
1F	7-5	FIELD	Field identification
1F	4-0	LTYPE	Line type identification
Subcarrier Registers			
20	7-0	FREQL	Subcarrier frequency 4th byte (LSBs)
21	7-0	FREQ3	Subcarrier frequency 3rd byte
22	7-0	FREQ2	Subcarrier frequency 2nd byte
23	7-0	FREQM	Subcarrier frequency 1st byte (MSBs)
24	7-0	SYSPHL	Video phase offset LSBs
25	7-0	SYSPHM	Video phase offset MSBs
26	7-0	BURPHL	Burst phase offset LSBs
27	7-0	BURPHM	Burst phase offset MSBs
28-3F			Reserved
Test I/O Register			
40	7-0	TESTDAT	Test data input/output
Mask Register			
50	7-0	MASK	Mask register
Y-Component Register			
60	7-0	Y	Y-component input/output

Notes:

1. Functions are listed in the order used for reading and writing.
2. For each register listed above, all bits not listed are reserved and should be set to zero to ensure proper operation.
3. The meaning of Register 04 (Key Control Register/Layering Control Register) is determined by Format Control Register bit 6 (TMC22191).

Control Register Definitions

Global Control Register (00)

7	6	5	4	3	2	1	0
Reserved			$\overline{\text{SRESET}}$	PAL	LUMDIS	CHRDIS	HRESET

Reg	Bit	Name	Function
00	7-5		Reserved.
00	4	$\overline{\text{SRESET}}$	Software reset. When LOW, resets and holds internal state machines and disables outputs. When HIGH (normal), starts and runs state machines and enables outputs.
00	3	PAL	Video standard select. When LOW, the NTSC standard is generated with 7.5 IRE pedestal. When HIGH, PAL standard video is generated. This bit is ignored if Register 0E bit 7 is HIGH, enabling the 0E and 0F registers.
00	2	LUMDIS	Luminance input disable. When LOW (normal), luminance (Y) data from external frame buffer is enabled. When HIGH, luminance (Y) data into the TMC22x91 is forced to 0 IRE but sync pulses continue from the LUMA output.
00	1	CHRDIS	Chrominance input disable. When LOW (normal), burst and frame buffer data into the TMC22x91 are enabled. When HIGH, burst and frame buffer data are suppressed, enabling monochrome operation.
00	0	HRESET	Software reset enable. $\overline{\text{SRESET}}$ is forced LOW when the $\overline{\text{RESET}}$ pin is taken LOW. State machines are reset and held. When HRESET is LOW, $\overline{\text{RESET}}$ may be taken HIGH at any time. The TMC22x91 is enabled and a new frame is begun with line 1, field 1 on the next PXCK after $\overline{\text{SRESET}}$ is set HIGH. The D/A converters are powered down while $\overline{\text{RESET}}$ is LOW. When HRESET is HIGH, a new frame is begun with line 1, field 1 on the next PXCK after $\overline{\text{RESET}}$ is taken HIGH. $\overline{\text{SRESET}}$ is ignored. The D/A converters remain active during the reset sequence.

Control Register Definitions (continued)

Format Control Register (01)

7	6	5	4	3	2	1	0
Reserved	LCREN	RAMPEN	\overline{CB}	FORMAT		INMODE	

Reg	Bit	Name	Function
01	7		Reserved.
01	6	LCREN	(TMC22191) Layering Control Register enable. When LOW, the Layering Control Register is not available and Key Control Register functions are enabled. In this mode, the TMC22191 functions like the TMC22091. When HIGH, the Layering Control Register takes the place of the Key Control Register and enables the layering functions. Data loaded into the Key or Layering Control Registers will remain but have a different meaning if this bit is changed.
01	5	RAMPEN	Modulated ramp test. When LOW (normal), the TMC22x91 encodes and outputs video corresponding to input data. When RAMPEN and \overline{CB} are both HIGH, an internally generated 40 IRE modulated ramp is produced, preempting input data.
01	4	\overline{CB}	Color bar test. When HIGH (normal), the TMC22x91 encodes and outputs video corresponding to input data. When \overline{CB} , RAMPEN, and Format Control Register bit 0 are LOW, internally generated color bars are produced, preempting input data.
01	3-2	FORMAT	PD23-0 input format select. Two bits select RGB, GBR, or YCBCR input data. When bits 3 and 2 are: 0 0 the CLUT output is interpreted as RGB and is converted to YCBCR. 0 1 is reserved. Bits 3 and 2 must be 00 or 10 when the Layering Control Register is enabled (TMC22191). 1 0 the CLUT output is interpreted as GBR, and is converted to YCBCR. 1 1 the CLUT output is interpreted as YCBCR.
01	1-0	INMODE	PD23-0 input mode select. These two bits set up the TMC22x91 for either 444, 422, 15-bit, or 8-bit input modes. 0 0 24-bit/pixel GBR, RGB, or YCBCR444 data enters from PD23-0 0 1 YCBCR422 data enters from PD23-8; CR and CB alternate from PD15-8 1 0 15-bit/pixel GBR or RGB data from PD14-0 1 1 8-bit/pixel color indexed data enters from PD7-0. Bits 1 and 0 must be 00, 01, or 11 when the Layering Control Register is enabled (TMC22191).

Control Register Definitions (continued)

Interface Control Register (02)

7	6	5	4	3	2	1	0
VITSEN	SHCY	TBASE		SOUT	FBDIS	PDCDIR	FLDLK

Reg	Bit	Name	Function
02	7	VITSEN	VITS lines enable. When LOW, all UBB lines in the vertical interval are black burst regardless of input data. When HIGH, all UBB lines in the vertical interval become UVV active video and are dependent upon input data.
02	6	SHCY	Short-cycle test mode. When LOW, normal operation is enabled. when HIGH, EH (equalization pulse HIGH length) and SL (vertical sync LOW length) are shortened by 256.
02	5-4	TBASE	Time-base source select. These two bits set up the TMC22x91 for either genlock or frame buffer control of timing. When bits 5 and 4 are: 0 0 the encoder counts out its own time-base from input clock PXCK. 0 1 the encoder locks to synchronizing signals from external genlock. 1 0 the encoder locks to synchronizing signals from frame buffer controller.
02	3	SOUT	Sync output mode select. When LOW, \overline{VHSYNC} and \overline{VVSYNC} output separate horizontal and vertical sync pulses. When HIGH, composite sync (H and V) is output on \overline{VVSYNC} while horizontal sync is output on \overline{VHSYNC} .
02	2	FBDIS	Frame buffer signals enable. When LOW, \overline{VVSYNC} and \overline{VHSYNC} outputs to frame buffer are enabled. When HIGH, \overline{VVSYNC} and \overline{VHSYNC} outputs to frame buffer are disabled.
02	1	PDCDIR	PDC master/slave select. When LOW, PDC is an output where the encoder is requesting data from the frame buffer. When HIGH, PDC is an input, and directs the encoder to accept data from the frame buffer.
02	0	FLDLK	Field lock select. When LOW, (in Slave mode) the encoder locks to each new field. When HIGH, the encoder locks to field 1 only.

Control Register Definitions (continued)

Test Control Register (03)

7	6	5	4	3	2	1	0
Reserved	LIMEN	TESTEN	HOLDEN	TSTMSB	LUMTST	8FSUBR	CHRTST

Reg	Bit	Name	Function
03	7		Reserved.
03	6	LIMEN	Luminance limiter enable. When LOW, all luminance values are passed to modulator. when HIGH, luminance values are limited to 101 IRE.
03	5	TESTEN	Test enable. When LOW, normal operation is enabled. When HIGH, TESTDAT ₇₋₀ (Register 40) is connected to the composite output (READ) and D/A converters (WRITE) for test.
03	4	HOLDEN	MSBs/LSBs hold select. When LOW, alternates MSBs and LSBs in test, at PXCK rate. When HIGH, reads/writes only MSBS or LSBS in test (per TSTMSB, bit 3)
03	3	TSTMSB	LSBS,MSBS hold select. When LOW, connects 2 LSBs to TESTDAT ₁₋₀ for testing when TESTEN is HIGH. When HIGH, connects 8 MSBs to TESTDAT ₇₋₀ for testing when TESTEN is HIGH.
03	2	LUMTST	LUMA channel test. When LOW (normal), the luminance D/A converter is driven from luminance channel. When HIGH, the luminance D/A converter is driven from TESTDAT for testing when TESTEN is HIGH.
03	1	8FSUBR	8-field subcarrier reset enable. When LOW, the internal subcarrier generator is reset with frequency and phase data from FREQ, SYSPH, and BURPH registers every eight fields. When HIGH, the internal subcarrier generator free-runs on the basis of frequency and phase data from the last time it was reset. When RESET goes LOW, the subcarrier frequency and phase will be reset from FREQ, SYSPH, and BURPH after field 8.
03	0	CHRTST	CHROMA channel test. When LOW (normal), the chrominance D/A converter is driven from chrominance channel. When HIGH, the chrominance D/A converter is driven from TESTDAT when TESTEN is HIGH.

Control Register Definitions (continued)

Key Control Register (04)

7	6	5	4	3	2	1	0
Reserved	HKEN	BUKEN	SKEXT	DKDIS	EKDIS	FKDIS	SKEN

Reg	Bit	Name	Function
04	7		Reserved.
04	6	HKEN	Hardware key enable. When LOW, the KEY input pin ignored. When HIGH, the KEY input pin is enabled.
04	5	BUKEN	Burst key enable. When LOW, output video burst is generated on TMC22x91. When HIGH, output burst is taken from genlock input data.
04	4	SKEXT	Data key operation select. When LOW, data keying is allowed only during active video. When HIGH, keying is allowed during active video and blanking.
04	3	DKDIS	Green/red/Y data key disable. When LOW, green/red/Y input data is enabled for data keying. When HIGH, green/red/Y input data is ignored for data keying. This function is enabled when Layering Control Register is enabled (TMC22191).
04	2	EKDIS	Blue/green/CB data key disable. When LOW, Blue/green/CB input data is enabled for data keying. When HIGH, Blue/green/CB input data is ignored for data keying. This function is enabled when Layering Control Register is enabled (TMC22191).
04	1	FKDIS	Red/blue/CR data key disable. When LOW, red/blue/CR input data is enabled for data keying. When HIGH, red/blue/CR input data is ignored for data keying. This function is enabled when Layering Control Register is enabled (TMC22191).
04	0	SKEN	Data key enable. When LOW, data keying is disabled. When HIGH, data keying is enabled.

Control Register Definitions (continued)

Layering Control Register (04) (TMC22191)

7	6	5	4	3	2	1	0
LAYMODE	HKEN	BUKEN	SKEXT	LAYMODE			SKEN

Reg	Bit	Name	Function
04	7	LAYMODE	MSB of Layer Assignments select.
04	6	HKEN	Hardware key enable. When LOW, the KEY input pin ignored. When HIGH, the KEY input pin is enabled.
04	5	BUKEN	Burst key enable. When LOW, output video burst is generated on TMC22191. When HIGH, output burst is taken from genlock input data.
04	4	SKEXT	Data key operation select. When LOW, data keying is allowed only during active video. When HIGH, data keying is allowed during active video and blanking.
04	3-1	LAYMODE	Three LSBs of Layer Assignments select.
04	0	SKEN	Data key enable. When LOW, data keying is disabled. When HIGH, data keying is enabled.

Key Value Registers (05-07)

Reg	Bit	Name	Function
05	7-0	DKEY	Green/red/Y data key value. Eight bits hold the match value which triggers keying on red/Y.
06	7-0	EKEY	Blue/green/U data key value. Eight bits hold the match value which triggers keying on green/U.
07	7-0	FKEY	Red/blue/V key value. Eight bits hold the match value which triggers keying on blue/V.

Control Register Definitions (continued)

Miscellaneous Control Register (0E)

7	6	5	4	3	2	1	0
EFEN	COMPDA	SVIDDA	FKREN	RATIO	TFLK	T512	CB100

Reg	Bit	Name	Function
0E	7	EFEN	Register 0E and 0F enable. When LOW, the functions of Register 0E and 0F are disabled. When HIGH, Registers 0E and 0F are active. When Registers 0E and 0F are enabled, Register 00 bit 3 is ignored. Register 0E bit 7 will read back whatever value was written.
0E	6	COMPDA	COMPOSITE D/A disable. When HIGH, the COMPOSITE D/A converter is powered-down. When LOW, the D/A is enabled.
0E	5	SVIDDA	LUMA/CHROMA D/A disable. When HIGH, the LUMA and CHROMA D/A converters are powered-down. When LOW, they are enabled.
0E	4	FKREN	Luminance processing enable. When FKREN is HIGH, the KEY input defines the function of CVBS input data. When the KEY input is HIGH, CVBS data is keyed over PD input data. When KEY is LOW, CVBS data is assumed to be luminance data delayed by one. When FKREN is LOW, the KEY input operates normally, switching between CVBS and PD data.
0E	3	RATIO	Luminance ratio control bit. When LOW, 1/2 of current luminance and 1/2 of field delayed luminance from the CVBS input are added to yield a new combined luminance value. When RATIO is HIGH, 3/4 of current luminance is added to 1/4 of the delayed luminance to produce a new luminance value.
0E	2	TFLK	Luminance-pass threshold. The difference between current luminance and delayed luminance (from the CVBS inputs) is compared against a preset threshold set by TFLK. When TFLK is LOW, the high threshold must be exceeded to trigger the combining of current and delayed luminance (according to RATIO). If the higher threshold is not exceeded, current luminance is passed without modification. When TFLK is HIGH, a lower threshold is used to trigger the combining of current and delayed luminance.
0E	1	T512	EH/SL offset control bit. When LOW, the true value of EH and SL is offset by 256. When HIGH, the true value for EH and SL is offset by 512.
0E	0	CB100	NTSC/PAL color bars select. When HIGH, color bars with 100% white level are selected. When LOW, color bars will have 75% white level.

Control Register Definitions (continued)

Standards Control Register (0F)

7	6	5	4	3	2	1	0
EFEN	SIX25	PALID	SETUP	YGAIN		CGAIN	

Reg	Bit	Name	Function
0F	7	EFEN	Same as Register 0E bit 7, but read-only.
0F	6	SIX25	Select 625 lines per frame. When HIGH, the encoder assumes 625 line per frame. When LOW, 525 lines per frame are assumed.
0F	5	PALID	PAL select. When HIGH, Phase alternate line (PAL) operation is selected. When LOW, operation conforms to NTSC standards.
0F	4	SETUP	Setup enable. When HIGH, a 7.5 IRE Pedestal is added to the output video. when LOW, no pedestal is added.
0F	3-2	YGAIN	Luminance gain settings are adjusted to conform to the following NTSC and PAL standards: 0 0 NTSC without SETUP 0 1 NTSC-A and PAL-M 1 0 PAL-I and PAL-N 1 1 Reserved
0F	1-0	CGAIN	Chrominance gain settings are adjusted to conform to the following NTSC and PAL standards: 0 0 NTSC without SETUP 0 1 NTSC-A and PAL-M 1 0 PAL-I and PAL-N 1 1 Reserved

Timing Registers (10-17)

Reg	Bit	Name	Function
10	7-0	SY	Horizontal sync tip length. This 8-bit register holds a value extending from 0 to 255 PCK cycles.
11	7-0	BR	Breezeway length. This 8-bit register holds a value extending from 0 to 255 PCK cycles.
12	7-0	BU	Burst length. This 8-bit register holds a value extending from 0 to 255 PCK cycles.
13	7-0	CBP	Color back porch length. This 8-bit register holds a value extending from 0 to 255 PCK cycles.
14	7-0	XBP	Extended color back porch 8 LSBs. This 8-bit register holds the LSBs of a 10-bit value extending from 0 to 1023 PCK cycles. The two MSBs are located in control register 18.
15	7-0	VA	Active video 8 LSBs. This 8-bit register holds the LSBs of a 10-bit value extending from 0 to 1023 PCK cycles. The two MSBs are located in control register 18.
16	7-0	VC	Active video start 8 LSBs. This 8-bit register holds the LSBs of a 10-bit value which is the initial half active video length extending from 0 to 1023 PCK cycles. The two MSBs are located in control register 18.
17	7-0	VB	Active video end 8 LSBs This 8-bit register holds the LSBs of a 10-bit value which is the end half active video length extending from 0 to 1023 PCK cycles. The two MSBs are located in control register 18.

Control Register Definitions (continued)

Timing Register (18)

7	6	5	4	3	2	1	0
XBP		VA		VC		VB	

Reg	Bit	Name	Function
18	7-6	XBP	Extended color back porch 2 MSBs. These two bits hold the MSBs of a 10-bit value extending from 0 to 1023 PCK cycles. The LSBs are located in control register 14.
18	5-4	VA	Active video 2 MSB. These two bits hold the MSBs of a 10-bit value extending from 0 to 1023 PCK cycles. The LSBs are located in control register 15.
18	3-2	VC	Active video start 2 MSBs. These two bits hold the MSBs of a 10-bit value which is the initial half active video length extending from 0 to 1023 PCK cycles. The LSBs are located in control register 16.
18	1-0	VB	Active video end 2 MSBs. These two bits hold the MSBs of a 10-bit value which is the end half active video length extending from 0 to 1023 PCK cycles. The LSBs are located in control register 17.

Timing Registers (19-1E)

Reg	Bit	Name	Function
19	7-0	FP	Front porch length. This 8-bit register holds a value extending from 0 to 255 PCK cycles.
1A	7-0	EL	Equalization pulse LOW length. This 8-bit register holds a value from 0 to 255 PCK cycles.
1B	7-0	EH	Equalization pulse HIGH length. This 8-bit register holds a value extending from 0 to 255 PCK cycles. This value, when added to 256 (or 512), determines the final pulse length in the range of 256 to 511 (or 767) PCK cycles.
1C	7-0	SL	Vertical sync LOW length. This 8-bit register holds a value from 0 to 255 PCK cycles. This value, when added to 256 (or 512), determines the final pulse length in the range of 256 to 511 (or 767) PCK cycles.
1D	7-0	SH	Vertical sync HIGH length. This 8-bit register holds a value extending from 0 to 255 PCK cycles.
1E	7-0	CBL	Color bar length. This 8-bit register holds a value which is the length of each color bar displayed extending from 0 to 255 PCK cycles.

Timing Register (1F)

7	6	5	4	3	2	1	0
FIELD				LTYPE			

Reg	Bit	Name	Function
1F	7-5	FIELD	Field identification (read only). These three bits are updated 12 PXCK periods after each VHSYNC. They allow the user to determine field type on a continuous basis.
1F	4-0	LTYPE	Line type identification (read only). These five bits are updates 5 PXCK periods after each VHSYNC. They allow the user to determine line type on a continuous basis.

Control Register Definitions (continued)

Subcarrier Registers (20-27)

Reg	Bit	Name	Function
20	7-0	FREQ1	Subcarrier frequency 4th byte (LSBs). This 8-bit register holds the LSB (bits 7-0) of the 32-bit subcarrier frequency value (non-genlock modes). The next eight most significant bits are held in Register 21.
21	7-0	FREQ3	Subcarrier frequency 3rd byte. This 8-bit register holds bits 15:8 of the subcarrier frequency value (non-genlock modes). The next eight most significant bits are held in Register 22.
22	7-0	FREQ2	Subcarrier frequency 2nd byte. This 8-bit register holds bits 23-16 of the subcarrier frequency value (non-genlock modes). The eight MSBs are held in Register 23.
23	7-0	FREQM	Subcarrier frequency 1st byte (MSBs). This 8-bit register holds the MSBs (bits 31-24) of the 32-bit subcarrier frequency value (non-genlock modes).
24	7-0	SYSPHL	Video phase offset LSBs. This 8-bit register holds the 8 LSBs of color subcarrier phase offset during active video.
25	7-0	SYSPHM	Video phase offset MSBs. This 8-bit register holds the 8 MSBs of color subcarrier phase offset during active video.
26	7-0	BURPHL	Burst phase offset LSBs. This 8-bit register holds the 8 LSBs of burst phase offset for color adjustment.
27	7-0	BURPHM	Burst phase offset MSBs. This 8-bit register holds the 8 MSBs of burst phase offset for color adjustment.

Test I/O Register (40)

Reg	Bit	Name	Function
40	7-0	TESTDAT	Test data input/output. This 8-bit register holds MSBs or LSBs, as determined by the Test Control Register. This control address does not auto-increment during read or write operations. To exit the test mode, reset the Control Register pointer by setting A1-0 and R/W LOW and then bring CS LOW.

Mask Register (50)

Reg	Bit	Name	Function
50	7-0	MASK	Mask register. This 8-bit register holds an 8-bit word that is logically ANDed with the incoming data presented to the three CLUTs in color-index mode. This register is a write-only register.

Y-Component Register (60)

Reg	Bit	Name	Function
60	7-0	Y	Y-component register. This register holds the contents of the luminance value before the Sync and Blank Insert circuitry of the encoder. Loading the Control Register pointer with 60h brings 8-bit Y values out on the D7-0 port.

Color Lookup Table

The CLUT can be used in a variety of ways, depending on the data format and source presented to the PD port.

The CLUT is loaded like a RAMDAC, sequentially writing one byte to each of the three locations associated with the selected CLUT address. These three locations are referred to as Tables D, E, and F as shown in table 16 (not R,G, and B because they may or may not contain RGB information). and are loaded in that sequence. The address will increment automatically after the three values at one address are written or read.

Color-index Modes

In color-index (CI) mode, the CLUT is used to store the color look-up data, translating the 8-bit source pixel data into 24-bit RGB colors. Table D holds red data, Table E is green data, and Table F holds blue Data. The incoming data are presented to the three tables in parallel, and a 24-bit output is produced.

When the encoder is connected in parallel with a RAMDAC in a VGA system, the CLUT can be loaded simultaneously with the CLUT in the output RAMDAC. If a 6-bit RAMDAC is employed, 6 bits can be loaded via data pins D7-2 (MSB justified). The two LSBs should be set to 00 for optimal black level representation, but the largest error introduced by extraneous data in the LSBs is 3/4 LSB (at 6 bits). The encoder will produce the closest possible translation of the VGA colors in the encoded video environment.

GBR/RGB Modes

The nominal configuration for GBR/RGB modes is unity gain (CLUT data = CLUT address) for PAL and NTSC. Other transfer functions, such as gain adjustment, offset, and

gamma correction, are easily loaded. The color data is loaded into the tables in G-B-R sequence in GBR mode, and R-G-B sequence in RGB mode.

Luminance/Color Difference Modes

The TMC22x91 expects Y, B-Y, and R-Y signals at the input to its modulator section. When presenting CCIR-601 YCB_{CR} or digitized Y, B-Y, R-Y data to the CLUT, gain and offset factors are needed. Table 4 specifies the recommended transfer functions. The CLUT is loaded in Y-CB-CR sequence.

Overlay Operation

For the TMC22091 and TMC22191 (when Format Control Register Bit 6 = LOW), the OL₄₋₀ inputs are inactive. In CCIR-601 operation, the nominal data range for Y is from 16 to 235 and for CB and CR is from 16 to 240. This means that CLUT locations 0 to 15 and 241 to 255 are available for overlay colors. When the overlay locations are addressed (by forcing CLUT addresses outside the normal CCIR-601 data range), the addressed CLUT data is encoded resulting in the specific color found in that CLUT location. Overlay colors information stored in the unused CLUT locations must be Y, B-Y, R-Y values. Y, B-Y, and R-Y values are found from RGB values by:

$$Y = 0.299 R + 0.587 G + 0.114 B$$

$$B-Y = -0.299 R - 0.587 G + 0.886 B$$

$$R-Y = 0.701 R - 0.587 G - 0.114 B$$

For the TMC22191, when the Format Control Register Bit 6 = HIGH, Overlay is controlled by the OL₄₋₀ inputs which directly access CLUT locations, 01 thru 0F and F1 thru FF, as shown in Table 5. The values stored in these CLUT locations must be in RGB format.

Table 4. CLUT Transfer Functions for NTSC and PAL

Input Format (CLUT Address)		Transfer Equations	Output Format (CLUT Data)	
Component	Data Range		Component	Data Range
R	0 to 255	$R_0=R$	R _O	0 to 255
G	0 to 255	$G_0=G$	G _O	0 to 255
B	0 to 255	$B_0=B$	B _O	0 to 255
Y	16 to 235	$Y_0 = Y * 1.1644 - 18.63$	Y _O	0 to 255
CB	±112	$(B-Y)_O = C_B * 1.0126$	(B-Y) _O	±113
CR	±112	$(R-Y)_O = C_R * 0.8011$	(R-Y) _O	±90
Y	0 to 255	$Y_0=Y$	Y _O	0 to 255
B-Y	±127	$(B-Y)_O = (B-Y) * 0.893$	(B-Y) _O	±113
R-Y	±127	$(R-Y)_O = (R-Y) * 0.7065$	(R-Y) _O	±90

Table 5. CLUT Locations Addressed by Overlay Inputs (TMC22191)

OL4-0	CLUT location
00	No Overlay
01	01
02	02
•	•
0E	0E
0F	0F
10	No Overlay
11	F1
12	F2
•	•
•	•

Table 5. CLUT Locations Addressed by Overlay Inputs (TMC22191) (continued)

OL4-0	CLUT location
1E	FE
1F	FF

Color-space Conversion in the Matrix

When the input pixels are in RGB, GBR, or color-index format and the CLUT is bypassed (TMC22191), the Matrix remains enabled, converting RGB data to color-difference format. When the input pixels are in 444 format (Y_CB_CR₄₄₄, RGB, GBR, CI), the Interpolator (which converts 422 to 444) is not active. When the input pixels are in Y_CB_CR format, the CLUT is enabled to scale the data to color-difference values and the Matrix is inactive. In color-index mode, the Matrix is active, converting the RGB CLUT output data to color-difference values.

Table 6. Pixel Input Operation for Format Control Register bit 6 = HIGH (TMC22191)

Format Control Register		Pixel Data Format	
FORMAT Bit 3,2	INMODE Bit 1,0	BYPASS = LOW CLUT bypassed	BYPASS = HIGH CLUT enabled
00 (RGB)	00 (444)	RGB	Y _C B _C R ₄₄₄
00	01 (422)	RGB	Y _C B _C R ₄₂₂
00	10 (15-bit)	RGB	RGB15
00	11 (CI)	RGB	CI
01	xx	reserved	reserved
10 (GBR)	00 (444)	GBR	Y _C B _C R ₄₄₄
10	01 (422)	GBR	Y _C B _C R ₄₂₂
10	10 (15-bit)	GBR	GBR15
10	11 (CI)	GBR	CI
11	xx	not allowed	not allowed

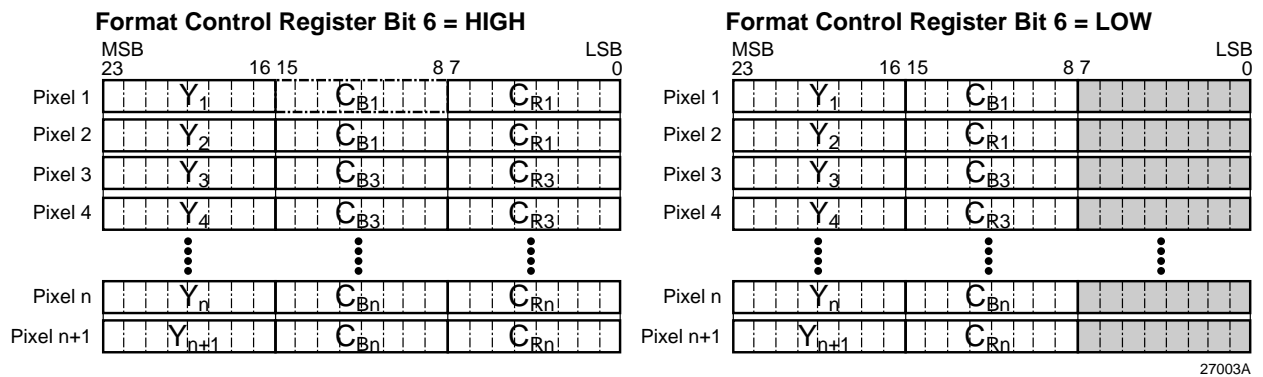

Note: The pixel input sequence begins on the first LDV pulse after PDC goes HIGH. n = Odd number

Figure 2. Pixel Data (PD23-0) Sequence for Y_CB_CR₄₂₂

Gamma Correction

Gamma is built into broadcast television systems as a correction factor for nonlinearity in image acquisition (nonlinear conversion of light into current in a vidicon) and at the display (phosphor nonlinearity in converting current into light).

A Gamma corrector transfer function takes the form of

$$\text{Output} = k (\text{Input})^{1/\gamma}$$

where a typical Gamma is 2.2 for NTSC, 2.8 for PAL.

Computer systems usually ignore Gamma in driving a display monitor. Each R, G, and B channel is treated as linear. When encoding a computer display output to video, the user must decide whether to apply a gamma correction factor and, if so, what value. It is a good assumption that, since the digital video input over the CVBS bus is in composite form, it has been Gamma corrected.

Gamma correction is applied in the RGB domain. When operating in YCbCr, for example when encoding a CCIR-601 signal, Gamma should have already been applied. Gamma correction is readily added to the RGB transfer equations shown in Table 4.

Video Timing

The TMC22x91 can be programmed to accommodate a wide range of system timing requirements. With a line locked pixel rate of 10 to 15 Mpps, the digitally synthesized horizontal waveforms and subcarrier frequency and phase are determined from 24 registers that are loaded by a controller.

Horizontal Programming

Horizontal interval timing is fully programmable, and is established by loading the timing registers with the durations of each horizontal element. The duration is expressed in PCK clock cycles. In this way, any pixel clock rate between 10 MHz and 15 MHz can be accommodated, and any desired standard or non-standard horizontal video timing may be produced. Figure 3 illustrates the horizontal blanking interval with timing register identification.

Horizontal timing parameters can be calculated as follows:

$$\begin{aligned} t &= N \times (\text{PCK period}) \\ &= N \times (2 \times \text{PXCK period}) \end{aligned}$$

where N is the value loaded into the appropriate timing register, and PCK is the pixel clock period.

Horizontal timing resolution is two PXCK periods. PXCK must be chosen such that it is an even integer multiple of the horizontal line frequency. This ensures that the horizontal line period, H, contains an integer number of pixels. The horizontal line comprises the sum of appropriate elements.

$$H = \text{FP} + \text{SY} + \text{BR} + \text{BU} + \text{CBP} + \text{VA}$$

When programming horizontal timing, subtract 5 PCK periods from the calculated values of CBP and add 5 PCK periods to the calculated value for VA.

Table 7. Horizontal Timing Specifications

Parameter	NTSC-M (μs)	PAL-I (μs)	PAL-M (μs)
FP	1.5	1.65	1.9
SY	4.7	4.7	4.95
BR	0.6	0.9	0.9
BU	2.5	2.25	2.25
CBP	1.6	2.55	1.8
VA	52.6556	51.95	51.692
H	63.5556	64.0	63.492

Vertical Programming

Vertical interval timing is also fully programmable, and is established by loading the timing registers with the durations of each vertical timing element, the duration expressed in PCK clock cycles. In this way as with horizontal programming, any pixel rate between 10 and 15 Mpps can be accommodated, and any desired standard or non-standard vertical video timing may be produced.

Like horizontal timing parameters, vertical timing parameters are calculated as follows:

$$\begin{aligned} t &= N \times (\text{PCK period}) \\ &= N \times (2 \times \text{PXCK period}) \end{aligned}$$

where N is the value loaded into the appropriate timing register, and PCK is the pixel clock period.

The Vertical Interval comprises several different line types based upon H, the Horizontal line time.

$$\begin{aligned} H &= (2 \times \text{SL}) + (2 \times \text{SH}) \text{ [Vertical sync pulses]} \\ &= (2 \times \text{EL}) + (2 \times \text{EH}) \text{ [Equalization pulses]} \end{aligned}$$

The VB and VC lines are added to produce the half-lines needed in the vertical interval at the beginning and end of some fields. These must properly mate with components of the normal lines.

$$\begin{aligned} \text{VB} &= \text{CBP} + \text{VA} - \text{XBP} = \text{H}/2 - \text{CBPVC} \\ &= \text{VA} - (\text{EL} + \text{EH}) = \text{VA} - \text{H}/2 \end{aligned}$$

where Equalization HIGH and LOW pulses (EL + EH) = H/2 and the Extended Color Back Porch, XBP = VA + CBP - VB. XBP begins after the end of burst, BU, taking the place of CBP in vertical interval UBV lines. Figure 5 shows the vertical sync and equalization pulse detail

Table 8. Vertical Timing Specifications

Parameter (μs)	NTSC-M (μs)	PAL-I (μs)	PAL-M (μs)
H	63.5556	64	63.492
EH	29.4778	29.65	29.45
EL	2.3	2.35	2.3
SH	4.7	4.7	4.65
SL	27.1	27.3	27.1

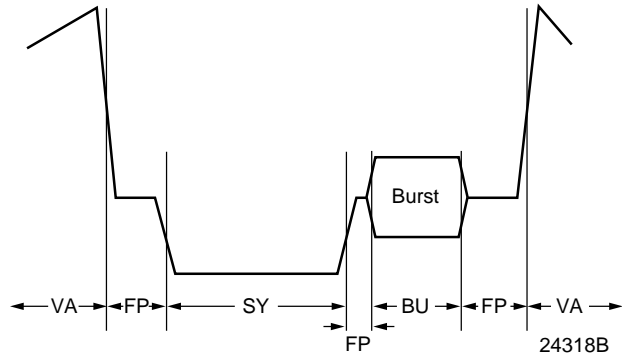

Figure 3. Horizontal Blanking Interval Timing

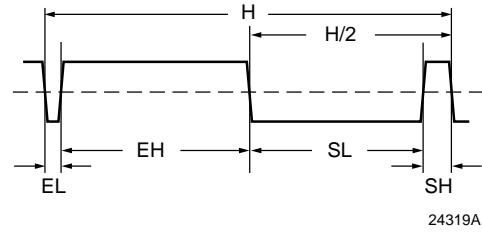

Figure 4. Sync and Equalization Pulse Detail Timing

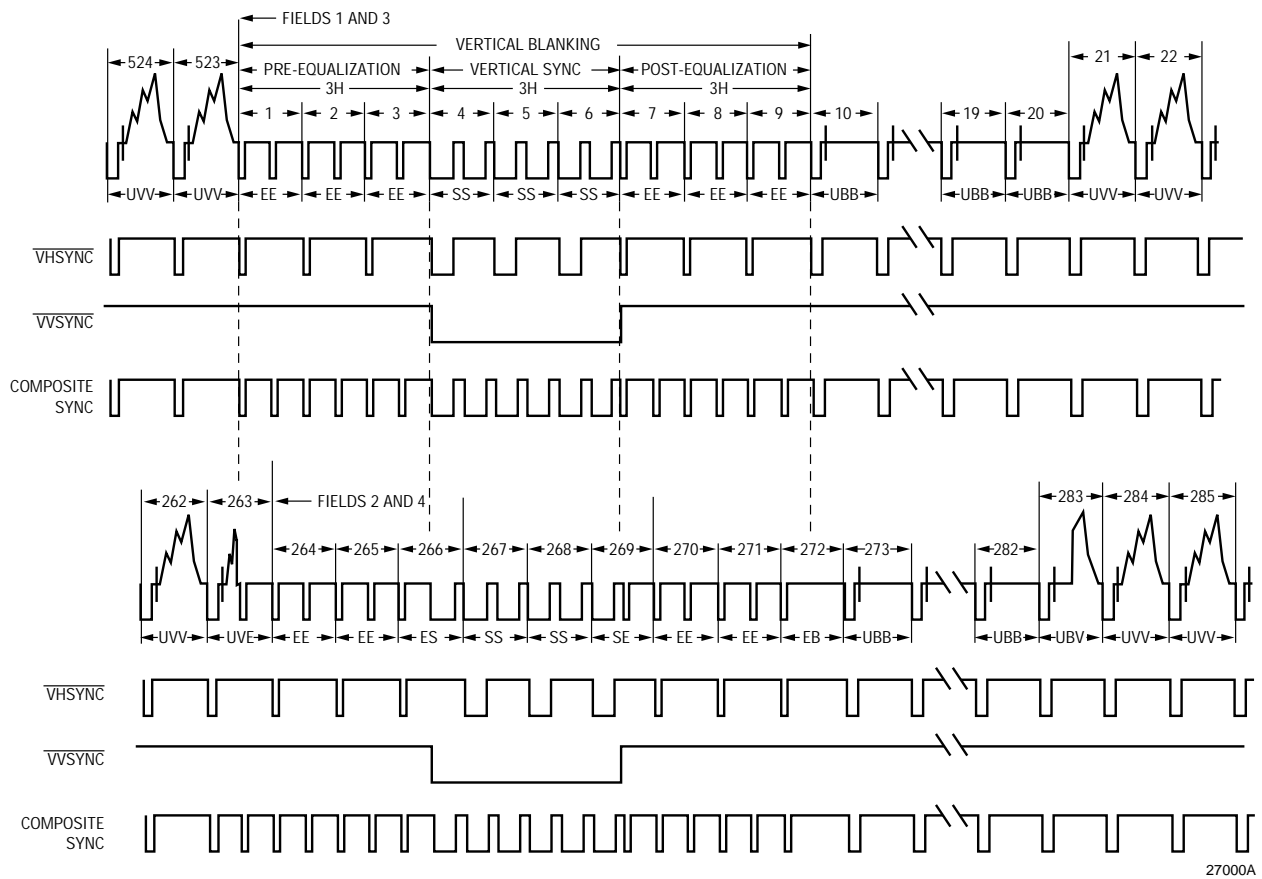

Figure 5. NTSC Vertical Interval

Table 9. NTSC Field/Line Sequence and Identification

Field 1 FIELD ID = x00			Field 2 FIELD ID = x01			Field 3 FIELD ID = x10			Field 4 FIELD ID = x11		
Line	ID	LTYPE	Line	ID	LTYPE	Line	ID	LTYPE	Line	ID	LTYPE
1	EE	00	264	EE	00	1	EE	00	264	EE	00
2	EE	00	265	EE	00	2	EE	00	265	EE	00
3	EE	00	266	ES	01	3	EE	00	266	ES	01
4	SS	03	267	SS	03	4	SS	03	267	SS	03
5	SS	03	268	SS	03	5	SS	03	268	SS	03
6	SS	03	269	SE	02	6	SS	03	269	SE	02
7	EE	00	270	EE	00	7	EE	00	270	EE	00
8	EE	00	271	EE	00	8	EE	00	271	EE	00
9	EE	00	272	EB	10	9	EE	00	272	EB	10
10	UBB	0D	273	UBB	0D	10	UBB	0D	273	UBB	0D
...
20	UBB	0D	282	UBB	0D	20	UBB	0D	282	UBB	0D
21	UVV	0F	283	UBV	0E	21	UVV	0F	283	UBV	0E
22	UVV	0F	284	UVV	0F	22	UVV	0F	284	UVV	0F
...
262	UVV	0F	524	UVV	0F	262	UVV	0F	524	UVV	0F
263	UVE	0C	525	UVV	0F	263	UVE	0C	525	UVV	0F

- EE Equalization pulse
- SS Vertical sync pulse
- EB Equalization broad pulse
- UVV Active video
- UBV Half-line black, half-line video
- SE Half-line vertical sync pulse, half-line equalization pulse
- ES Half-line equalization pulse, half-line vertical sync pulse
- UBB Black burst
- UVE Half-line video, half-line equalization pulse

Master and Genlock mode details of \overline{VHSYNC} , \overline{VVSYN} , and composite \overline{VVSYN} (SOUT = HIGH) outputs are shown in Figures 5 and 6. When \overline{VHSYN} and \overline{VVSYN}

are used as inputs (Slave mode), their falling edges mark the beginning of the sync interval and the width of the input pulse is specified under Operating Conditions.

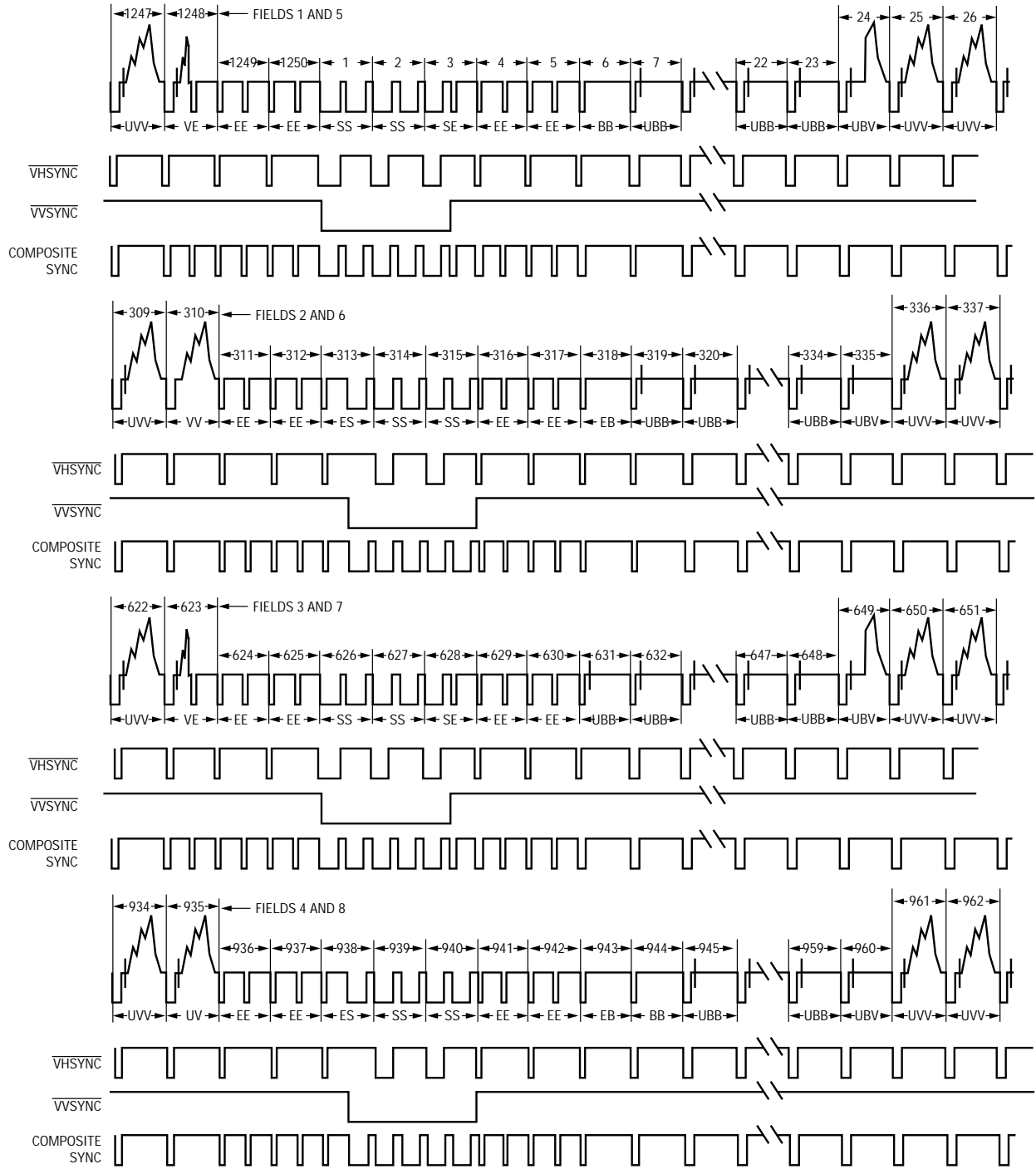

27001A

Figure 6. PAL Vertical Interval

Table 10. PAL Field/Line Sequence and Identification

Field 1 FIELD ID = 000, 100			Field 2 FIELD ID = 001, 101			Field 3 FIELD ID = 010, 110			Field 4 FIELD ID = 011, 111		
Line	ID	LTYPE	Line	ID	LTYPE	Line	ID	LTYPE	Line	ID	LTYPE
1	SS	03	313	ES	01	626	SS	03	938	ES	01
2	SS	03	314	SS	03	627	SS	03	939	SS	03
3	SE	02	315	SS	03	628	SE	02	940	SS	03
4	EE	00	316	EE	00	629	EE	00	941	EE	00
5	EE	00	317	EE	00	630	EE	00	942	EE	00
6	-BB	05	318	EB	10	631	UBB	0D	943	EB	10
7	UBB	0D	319	UBB	0D	632	UBB	0D	944	-BB	05
8	UBB	0D	320	UBB	0D	633	UBB	0D	945	UBB	0D
...
22	UBB	0D	335	UBB	0D	647	UBB	0D	960	UBB	0D
23	UBV	0E	336	UVV	0F	648	UBV	0E	961	UVV	0F
24	UVV	0F	337	UVV	0F	649	UVV	0F	962	UVV	0F
...
308	UVV	0F	621	UVV	0F	933	UVV	0F	1246	UVV	0F
309	UVV	0F	622	-VV	07	934	UVV	0F	1247	UVV	0F
310	-VV	07	623	-VE	04	935	UVV	0F	1248	-VE	04
311	EE	00	624	EE	00	936	EE	00	1249	EE	00
312	EE	00	625	EE	00	937	EE	00	1250	EE	00

- | | | | |
|-----|------------------------------------------------------------------------|-----|-------------------------------------------------------------|
| EE | Equalization pulse | SE | Half-line vertical sync pulse, half-line equalization pulse |
| SS | Vertical sync pulse | ES | Half-line equalization pulse, half-line vertical sync pulse |
| EB | Equalization broad pulse | UBB | Black burst |
| -BB | Black burst with color burst suppressed | UVV | Active video |
| -VV | Active video with color burst suppressed | UVE | Half-line video, half-line equalization pulse |
| -VE | Half-line video, half-line equalization pulse, color burst suppressed. | UBV | half-line black, half-line video |

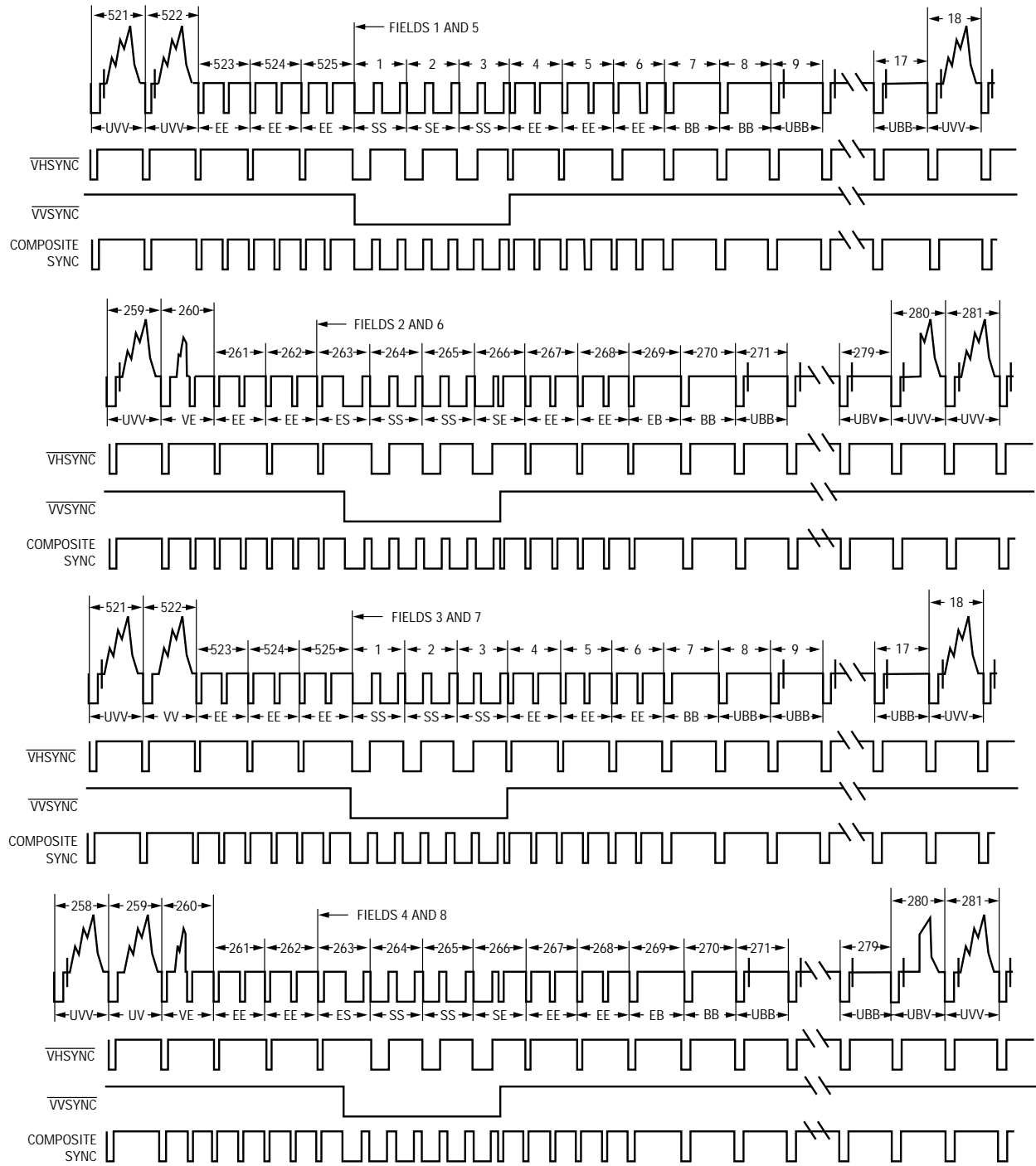

27082A

Figure 7. PAL-M Vertical Interval

Table 11. PAL-M Field/Line Sequence and Identification

Field 1 FIELD ID = 000, 100			Field 2 FIELD ID = 001, 111			Field 3 FIELD ID = 010, 110			Field 4 FIELD ID = 011, 111		
Line	ID	LTYPE	Line	ID	LTYPE	Line	ID	LTYPE	Line	ID	LTYPE
1	SS	03	263	ES	01	1	SS	03	263	ES	01
2	SS	03	264	SS	03	2	SS	03	264	SS	03
3	SS	03	265	SS	03	3	SS	03	265	SS	03
4	EE	00	266	SE	02	4	EE	00	266	SE	02
5	EE	00	267	EE	00	5	EE	00	267	EE	00
6	EE	00	268	EE	00	6	EE	00	268	EE	00
7	-BB	05	269	EB	10	7	-BB	05	269	EB	10
8	-BB	05	270	-BB	05	8	UBB	05	270	-BB	05
9	UBB	0D	271	UBB	1D	271	UBB	1D
...	17	UBB	0D.
17	UBB	0D	279	UBB	0D	18	UVV	0F	279	UBB	0D
18	UVV	0F	280	UBV	0E.	280	UBV	0E.
...	281	UVV	0F	258	UVV	0F	281	UVV	0F
259	UVV	0F	259	-VV	07
260	-VE	04	521	UVV	0F	260	-VE	04	521	UVV	0F
261	EE	00	522	-VV	07	261	EE	00	522	UVV	0F
262	EE	00	523	EE	00.	262	EE	00	523	EE	00
			524	EE	00				524	EE	00
			525	EE	00				525	EE	00

- | | | | |
|-----|------------------------------------------------------------------------|-----|-------------------------------------------------------------|
| EE | Equalization pulse | SE | Half-line vertical sync pulse, half-line equalization pulse |
| SS | Vertical sync pulse | ES | Half-line equalization pulse, half-line vertical sync pulse |
| EB | Equalization broad pulse | UBB | Black burst |
| -BB | Black burst with color burst suppressed | UVV | Active video |
| -VV | Active video with color burst suppressed | UVE | Half-line video, half-line equalization pulse |
| -VE | Half-line video, half-line equalization pulse, color burst suppressed. | UBV | half-line black, half-line video |

Table 12. Standard Timing Parameters

Standard	Field Rate (Hz)	Horizontal Freq. (kHz)	Pixel Rate (Mpps)	PXCK Freq. (MHz)	Timing Register (hex)															
					SY 10	BR 11	BU 12	CBP 13	XBP 14	VA 15	VC 16	VB 17	Note 1 18	FP 19	EL 1A	EH ² 1B	SL ² 1C	SH 1D	CBL 1E	
NTSC sqr. pixel	59.94	15.734266	12.27	24.54	3A	07	1F	0F	23	8B	05	77	65	12	1C	6A	4C	3A	52	
NTSC CCIR-601	59.94	15.734266	13.50	27.00	40	08	22	13	3F	CA	1D	9D	65	13	1F	8E	6E	3F	59	
NTSC 4x FSC	59.94	15.734266	14.32	28.64	43	09	24	12	54	F7	30	B5	65	15	21	A6	84	43	5F	
PAL sqr. pixel	50.00	15.625000	14.75	29.50	45	0D	21	21	6D	03	2B	B7	75	19	23	B5	93	45	61	
PAL CCIR-601	50.00	15.625000	13.50	27.00	40	0C	1E	22	4D	BE	0E	93	65	16	20	90	71	3F	58	
PAL 15 Mpps	50.00	15.625000	15.00	30.00	46	0D	22	21	73	11	31	BF	75	19	23	BD	9A	47	62	
PAL-M sqr.pixel	60.00	15.750000	12.50	25.01	3E	0B	1C	13	26	86	FE	8B	61	18	1D	70	53	3A	52	
PAL-M CCIR-601	60.00	15,750000	13.50	27.00	44	0C	1E	13	26	Bf	12	99	65	1A	1F	8E	6E	3F	57	
PAL-M 4x FSC	60.00	15,750000	14.30	28.60	47	0D	20	15	4C	E8	22	AC	65	1B	21	A5	84	42	5D	

Notes:

1. XBP, VA, VC, and VB are 10-bit values. The 2 MSBs for these four variables are in Timing Register 18. See Table 3.
2. EH and SL are 9-bit values. A most significant "1" is forced by the TMC22x91 since EH and SL must range from 256 to 511. EH and SL may be extended to 767. Only the eight LSBs are stored in Timing Registers 1B and 1C.
3. Every calculated timing parameter has a minimum value of 5 except EH and SL which have minimum values of 256.

VITS Insertion

In both NTSC and PAL, the TMC22x91 can be set up to allow Vertical Interval Test Signals (VITS) in the vertical interval in place of normal black burst lines (UBB). This is controlled by Interface Control Register bit 7. If this bit is LOW, UBB lines are black burst and are independent of TMC22x91 input data. If the bit is HIGH, all vertical interval UBB lines become UVV. UVV lines are active video and depend upon data input to the TMC22x91. VITS lines may carry special test signals or pass captioning data through the encoder.

Edge Control

SMPTE 170M NTSC and Report 624 PAL video standards call for specific rise and fall times on critical portions of the video waveform. The TMC22x91 does this automatically. The TMC22x91 digitally defines slopes compatible with SMPTE 170M NTSC or CCIR Report 624 PAL on:

1. H and V Sync leading and trailing edges.
2. Burst envelope.
3. Active video leading and trailing edges.

Subcarrier Programming

The color subcarrier is produced by an internal 32-bit digital frequency synthesizer which is completely programmable in frequency and phase. Separate registers are provided for phase adjustment of the color burst and of the active video, permitting external delay compensation and color adjustment.

In Master or Slave mode, the subcarrier is internally synchronized to establish and maintain a specified relationship between the falling edge of horizontal sync and color burst phase (SCH). In NTSC and PAL, SCH synchronization is performed every eight fields, on field 1 of the eight-field sequence. Proper subcarrier phase is maintained through the entire eight fields, including the 25 Hz offset in PAL systems. See the description of 8FSUBR under Test Control Register bit 1 for the subcarrier reset function.

In Genlock mode, the phase and relative frequency of the incoming video are transmitted by the TMC22071 Genlocking Video Digitizer over the CVBS bus at the beginning of each line, which synchronize the digital subcarrier synthesizer. When key control register bit BUKEN is HIGH and digitized burst from the TMC22071 is passed through to the reconstruction D/A converter, the reference subcarrier for the chrominance modulator is still synthesized within the encoder.

NTSC Subcarrier

For NTSC encoding, the subcarrier synthesizer frequency has a simple relationship to the pixel clock period, repeating over 2 lines: The decimal value is:

$$FREQ = \frac{(455/2)}{(\text{pixels/line})} \times 2^{32}$$

This value must be converted to binary and split into four 8-bit registers, FREQM, FREQ2, FREQ3, and FREQ4. The number of pixels/line is:

$$\text{Pixels/line} = (2/\text{PXCK frequency}) (\text{H period})$$

SYSPH establishes the appropriate phase relationship between the internal synthesizer and the chroma modulator. The nominal value for SYSPH is zero.

Other values for SYSPH must be converted to binary and split into two 8-bit registers, SYSPHM and SYSPHL.

Burst Phase (BURPH) sets up the correct relative NTSC modulation angle. The value for BURPH is:

$$BURPH = SYSPH + 8,192$$

This value must be converted to binary and split into two 8-bit registers, BURPHM and BURPHL. The decimal number 8,192 advances the burst phase by 45°.

PAL Subcarrier

The PAL relationship is more complex, repeating only once in 8 fields (the well-known 25 Hz offset):

$$FREQ = \frac{(1135/4) + (1/625)}{(\text{pixels/line})} \times 2^{32}$$

This value must be converted to binary and split as described previously for NTSC.

For PAL, the decimal value for SYSPH is found from:

$$SYSPH = \frac{FREQ}{2^{17}} = BURPH$$

This value must be converted to binary and split into two 8-bit registers, SYSPHM and SYSPHL. Burst Phase in PAL is identical to SYSPH. Therefore, the same values for SYSPHM and SYSPHL must be used for BURPHM and BURPHL.

PAL-M Subcarrier

$$FREQ = \frac{(909/4)}{(\text{pixels/line})} \times 2^{32}$$

$$SYSPH = \frac{FREQ}{2^{17}} = BURPH$$

Table 13. Standard Subcarrier Parameters

Standard	Field Rate (Hz)	Horizontal Freq. (kHz)	Pixel Rate (MHz)	PXCK Freq. (MHz)	Sub-carrier Freq. (MHz)	Subcarrier Register (hex)							
						BURPHM 27	BURPHL 26	SYSPHM 25	SYSPHL 24	FREQM 23	FREQ2 22	FREQ3 21	FREQ4 20
NTSC sq. pixel	59.94	15.734266	12.27	24.54	3.57954500	20	00	00	00	4A	AA	AA	AB
NTSC CCIR-601	59.94	15.734266	13.50	27.00	3.57954500	20	00	00	00	43	E0	F8	3E
NTSC 4x fSC	59.94	15.734266	14.32	28.64	3.57954500	20	00	00	00	40	00	00	00
PAL sq. pixel	50.00	15.625000	14.75	29.50	4.43361875	00	00	00	00	4C	F3	18	19
PAL CCIR-601	50.00	15.625000	13.50	27.00	4.43361875	00	00	00	00	54	13	15	96
PAL 15 Mpps	50.00	15.625000	15.00	30.00	4.43361875	00	00	00	00	4B	AA	C6	A1
PAL-M sq. pixel	60	15.750	12.50	25.01	3.57561149	00	00	00	00	49	45	00	51
PAL-M CCIR-601	60	15,750	13.50	27.00	3.57561149	00	00	00	00	43	DF	3F	D7
PAL-M 4x fSC	60	15,750	14.30	28.60	3.57561149	00	00	00	00	40	10	66	F5

SCH Phase Error Correction

SCH refers to the timing relationship between the 50% point of the leading edge of horizontal sync and the positive or negative zero-crossing of the color burst subcarrier reference. SCH error is usually expressed in degrees of subcarrier phase. In PAL, SCH is defined for line 1 of field 1, but since there is no color burst on line 1, SCH is usually measured at line 7 of field 1. The need to specify SCH relative to a particular line in PAL is due to the 25 Hz offset of PAL subcarrier frequency. Since NTSC has no such 25 Hz offset, SCH applies to all lines.

The SCH relationship is only important in the TMC22x91 when two video sources are being combined or if the composite video output is externally combined with another video source. In these cases, improper SCH phasing will result in a noticeable horizontal jump of one image with respect to another and/or a change in hue proportional to the SCH error between the two sources.

SCH phasing can be adjusted by modifying BURPH and SYSPH values by equal amounts. SCH is advanced/delayed by one degree by increasing/decreasing the value of BURPH and SYSPH by approximately B6h. An SCH error of 15° is corrected with SYSPH and BURPH offsets of AAAh.

Video Test Signals

The TMC22x91 has two standard video test waveforms for evaluating video signal integrity. They are selected and controlled by the Format Control Register.

Setting the Format Control Register bits 0, 4, and 5 LOW generates standard color bars at the COMPOSITE output

(Figure 11), the luminance component stair-step signal at the LUMA output, and the chrominance component on the CHROMA output. The six colors are 100% saturated PAL and 75% saturated for NTSC.

The percentage color saturation is selectable via Misc. Control Register 0E, bit 0.

The color bar test pattern comprises eight equal-width bars during VA, the active video period. The Timing Register value for CBL is found from:

$$CBL = \frac{VA + 7}{8}$$

If CBL is larger than this, the color bars are truncated at the end of VA. If CBL is smaller than VA/8, the color bar sequence will repeat, starting with another white bar. From left to right color bars 1 to 8 should be white, yellow, cyan, green, magenta, red, blue, and black.

The modulated ramp waveform is enabled by setting the Format Control Register to 30h. It comprises constant-amplitude and constant-phase subcarrier modulation superimposed on a linear ramp which slews from black to white during the active video portion of each horizontal line (Figure 12). This waveform is useful in making differential gain and differential phase measurements. Differential gain is a measure of the variation in saturation of a color as the luminance component is varied from black to white. Differential phase is a measure of the variation in hue of a color as the luminance component is varied from black to white.

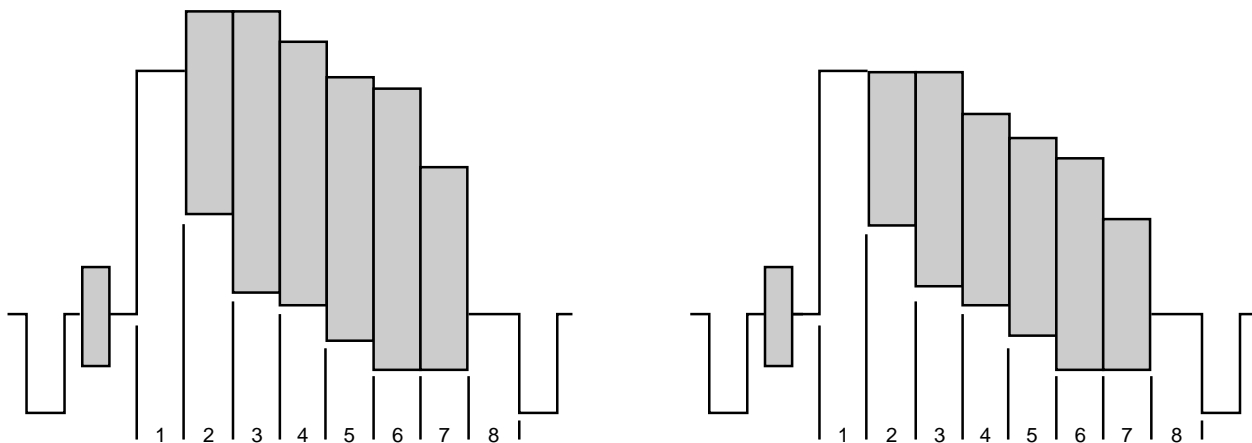

Figure 8. 100% Color Bars With 100% and 75% Chrominance Saturation

24387A

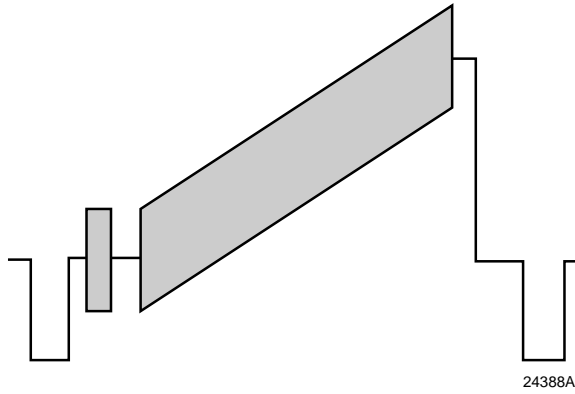

Figure 7. Modulated Ramp Waveform

Microprocessor Interface

The microprocessor interface comprises 13-lines. Two address bits provide four addresses for device programming and CLUT/register management. Address bit 0 selects between control registers and CLUT memory. Address bit 1 selects between reading/writing the register addresses and reading/writing register or CLUT data.

When writing, the address is presented along with a LOW on the R/\bar{W} pin during the falling edge of \bar{CS} . Eight bits of data are presented on D7-0 during the subsequent rising edge of \bar{CS} .

One additional falling edge of \bar{CS} is needed to move input data to the assigned working registers.

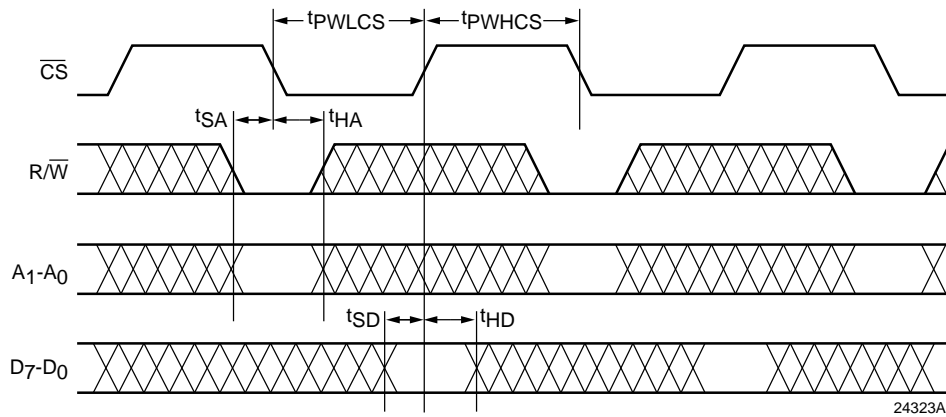

Figure 10. Microprocessor Port – Write Timing

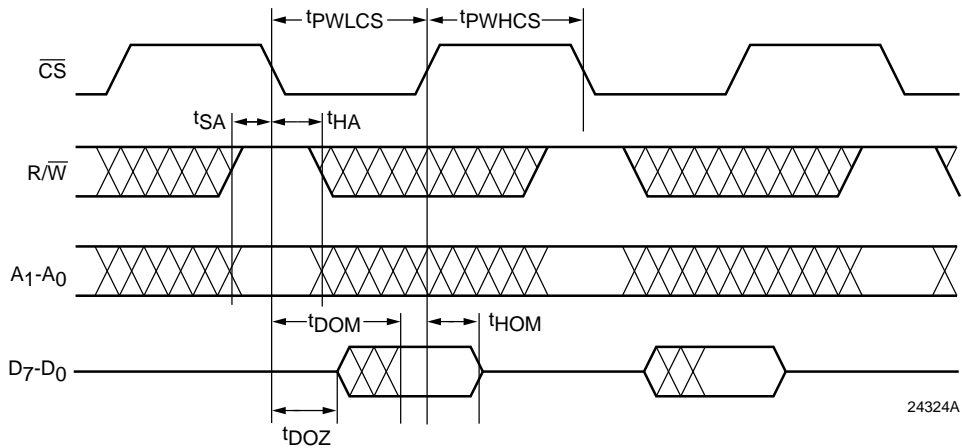

Figure 11. Microprocessor Port – Read Timing

In read mode, the address is accompanied by a HIGH on the R/W pin during a falling edge of CS. The data output pins go to a low-impedance state t_{DOZ} ns after CS falls. Valid data is present on D7-0 tDOM after the falling edge of CS. Because this port operates asynchronously with the pixel timing, there is an uncertainty in this data valid output delay of one PXCK period. This uncertainty does not apply to tDOZ.

The RESET pin restores the TMC22x91 to field 1 line 1 and places the encoder in a power-down state (if HRESET is LOW). Bit 4 of the Global Control Register (SRESET) is set LOW. All other control words and CLUT contents are left unchanged. Returning RESET HIGH synchronizes the internal clock with PXCK and restores the device outputs to active states.

Reading Pixel Data from the D7-0 Port

The microprocessor port of the TMC22x91 may be used to monitor digital video outputs. The eight MSBs of the up-sampled and interpolated pixel data that go to the COMPOSITE D/A converter can also be accessed via the D7-0 port. When the Test Control Register is loaded with 28h and the Control Register pointer is loaded with 40h, the D7-0 port will output the 8-bit composite pixels synchronous with PXCK. To halt the pixel flow from D7-0, simply bring CS HIGH.

Luminance pixel data may also be read from D7-0. In this case, the eight MSBs of luminance at the input of the Sync

and Blank Insert block are monitored. When the Control Register pointer is loaded with 60h, the D7-0 port will output 8-bit luminance pixels synchronous with respect to PXCK. To halt the pixel flow from D7-0, bring CS HIGH.

Operational Timing

The TMC22x91 operates in three distinct modes:

1. Master mode. The encoder independently produces all internal timing and provides digital sync to the host controller.
2. Slave mode. The encoder accepts horizontal and vertical sync from the controller and synchronizes the video output accordingly.
3. Genlock mode. The encoder accepts horizontal and vertical sync from the companion TMC22071 Genlocking Video Digitizer, synchronizes itself to the incoming video, and provides appropriate H Sync and V Sync to the host. It synchronizes Pixel Data input in two ways:
 - a. Internal PDC. The encoder internally generates the Pixel Data Control (PDC) signal which calls for data input from the external pixel source.
 - b. External PDC. The encoder receives a PDC signal from the host and accepts Pixel Data based on that input.

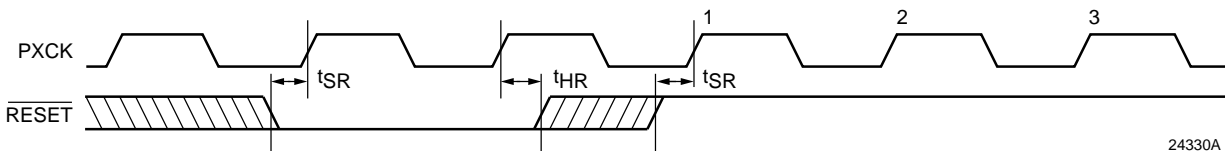

Figure 12. Reset Timing – PCK Synchronization

Reset Timing

The TMC22x91 operates from a master clock (PXCK) at twice the pixel rate. In Master mode, the PCK to PXCK timing relationship is set on the rising edge of RESET. In Figure 12, PCK is denoted by odd PXCK counts.

When RESET is taken LOW with sufficient setup time (t_{SR}) before a rising edge of PXCK, the internal state machines are reset and the device is put into a mode as dictated by the Global Control Register bits 0 and 4. In Master mode, when the RESET pin is taken HIGH, the internal clock timing is established. In Slave and Genlock mode, this timing is established by VHSYNC and GHSYNC respectively. The first PXCK following this RESET rising edge is designated as PXCK 1. Where it is significant, reference PXCK timing will be shown with numbered rising edges. A designation of 2N clocks refers to an even number of PXCK rising edges from device reset. If RESET is not shown and clock numbering

does not refer to 2N, timing is relative to signals shown in the diagram only.

Pixel Data Input Timing

PXCK is internally divided by 2 to generate an internal pixel clock, PCK which is not accessible from the pins of the TMC22x91. To ensure the correct phase relationship between PCK and pixel data, PCK is locked to VHSYNC or GHSYNC (Slave or Genlock mode, respectively). In Master mode, VHSYNC is produced on the rising edge of PCK allowing external circuitry to synchronize the generation of pixel data and LDV which also operates at the rate of PCK.

The rising edge of LDV clocks the 24-bit pixel data into three 8-bit registers while PCK clocks that data through the pixel data path within the TMC22x91. It is therefore necessary to meet the set-up and hold timing between pixel data and LDV as well as LDV and PCK as shown in Figure 13.

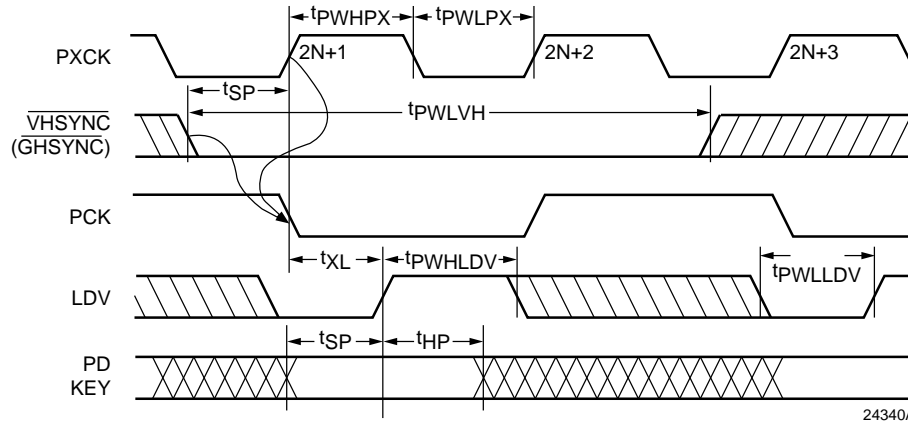

Figure 13. Slave Mode PD Port Interface Timing (Genlock Mode)

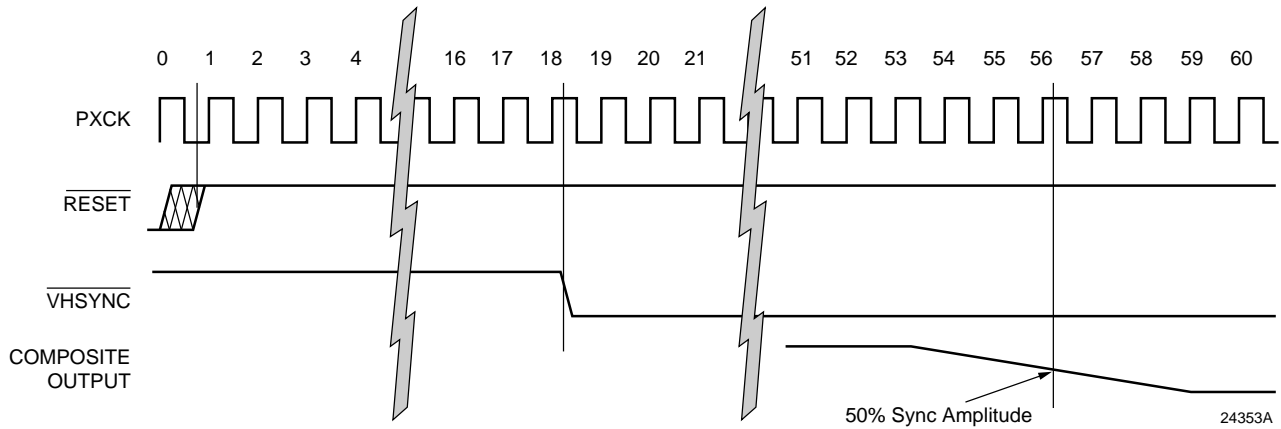

Figure 14. Master Mode Timing

Master Mode

In Master mode, initial timing is determined from the $\overline{\text{RESET}}$ input, and subsequent cycles result from programmed values in the Timing Control Registers. The Horizontal Sync output, $\overline{\text{VHSYNC}}$, goes LOW 18 PXCK clock cycles after the device is reset. The 50% point of the falling edge of sync LOW on line 4 of field 1 (NTSC) or line 1 of field 1 (PAL) occurs at the COMPOSITE and LUMA outputs 56 clocks after reset, or 38 clocks after $\overline{\text{VHSYNC}}$. See Figure 14, Master Mode Timing.

Slave Mode

In Slave mode, the 50% point of the falling edge of sync occurs 46 PXCK clocks after the falling edge of $\overline{\text{VHSYNC}}$, which is an input signal to the TMC22x91. This must be provided by the host to begin every line. If it is early, the line will be started early, maintaining the 52 clock delay to output. If it comes late, the front porch portion of the output waveform will be extended as necessary. See Figure 15, Slave Mode Timing.

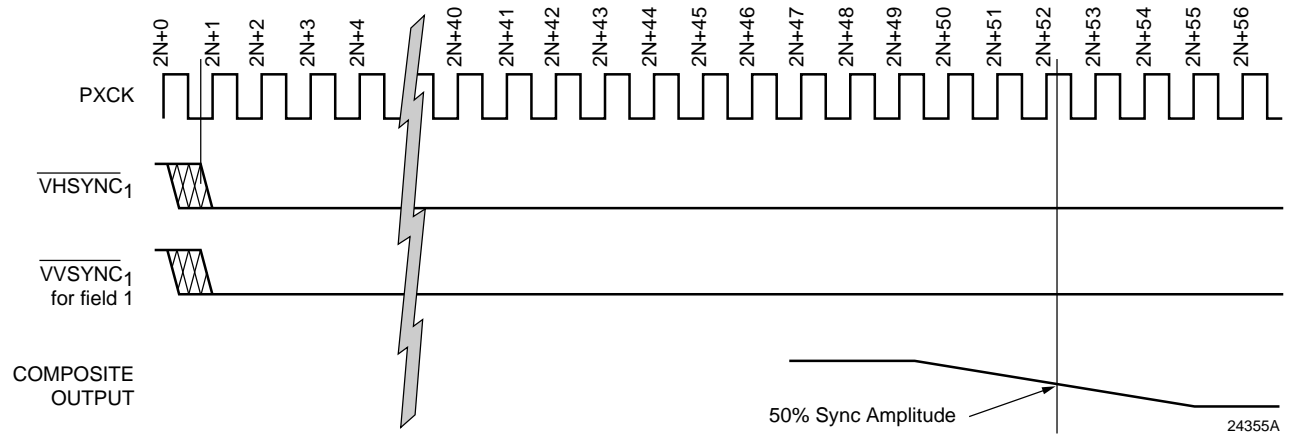

Figure 15. Slave Mode Timing

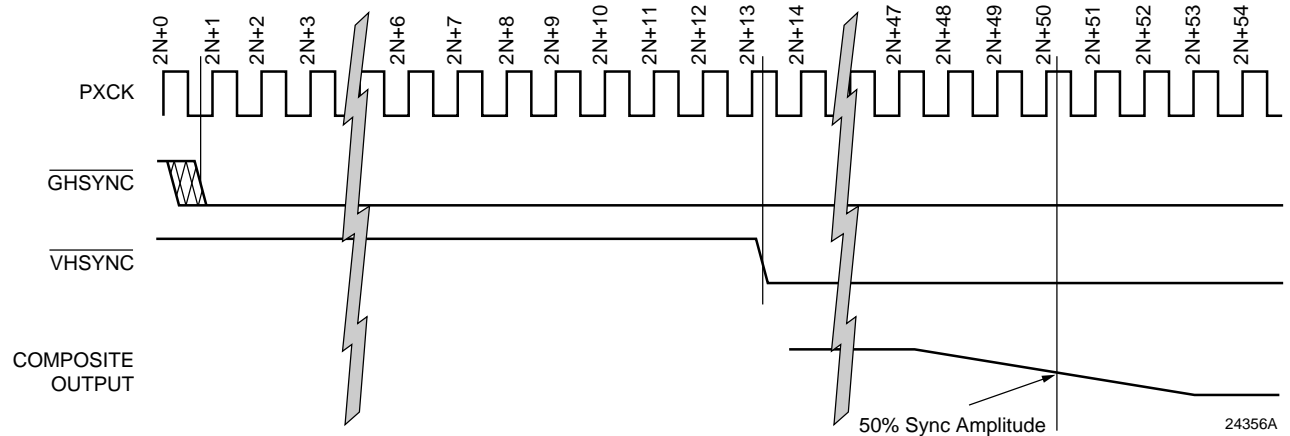

Figure 16. Genlocked Mode Timing

Genlocked Mode

In Genlocked mode, the encoder receives sync signals over the $\overline{\text{GHSYNC}}$ and $\overline{\text{GVSYNC}}$ inputs, and provides $\overline{\text{VHSYNC}}$ and $\overline{\text{VVSNC}}$ to the host. The 50% sync amplitude point occurs 50 PXCK clocks after $\overline{\text{GHSYNC}}$ goes LOW, while $\overline{\text{VHSYNC}}$ is produced at clock 13. If $\overline{\text{GHSYNC}}$ is late, the front porch is lengthened, if it is early, front porch is shortened. See Figure 16, Genlock Mode Timing.

Pixel Data Control

The Pixel Data Control (PDC) signal determines the active picture area. It may be an input or an output, as determined by the Interface Control Register bit 1.

The position (number of PCK cycles) of the rising edge of PDC relative to the falling edge of $\overline{\text{VHSYNC}}$ can be found by summing SY, BU, BR, and CBP. See Figure 17.

External Pixel Data Control

When used as an input, PDC goes HIGH four PXCK cycles before the first valid pixel of a line is presented to the PD input port. If this signal is late (with respect to the horizontal blanking interval programmed in the timing control registers), the Color Back Porch (CBP) will be extended. If it is early, incoming pixel data will be ignored until the end of the CBP.

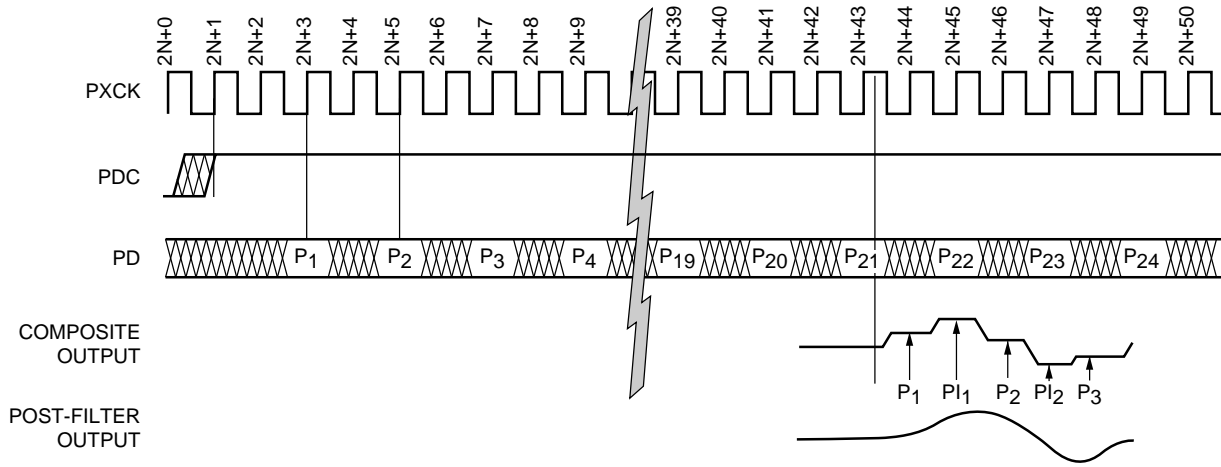

24358A

Figure 17. External Pixel Data Control

Internal Pixel Data Control

When programmed as an output, PDC goes HIGH four PXCK periods prior to the end of CBP (as programmed in the horizontal timing registers) which is also four PXCK cycles prior to required input of the first pixel of a line.

Pixels produced by the encoder appear at the analog outputs (COMPOSITE, LUMA, CHROMA) 40 clocks after they are registered into the PD port. Note that the pixels enter at one-half the PXCK rate. The encoded signal passes through interpolation filters which generate intermediate output values, improving the output frequency response and greatly simplifying the external reconstruction filter. The interpolated pixels are designated PI in the diagram.

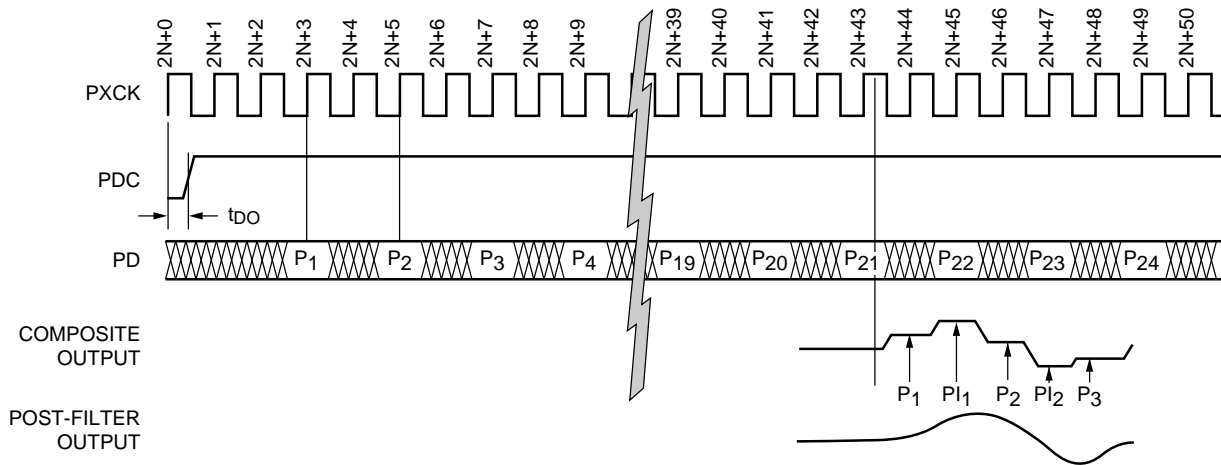

24357A

Figure 18. Internal Pixel Data Control

Layering with the TMC22191

Layering is a video production process where various images or patterns are superimposed (keyed) over each other to form a layered composite of the input images. Four layers with the following priority are provided by the TMC22191:

1. The DOWNSTREAM KEY layer keys over all other layers.
2. The FOREGROUND layer keys over MIDGROUND and BACKGROUND, but not over DOWNSTREAM KEY.
3. The MIDGROUND layer keys over BACKGROUND, but not over FOREGROUND or DOWNSTREAM KEY.
4. The BACKGROUND layer never keys over any other layer.

It is important not to confuse layers with sources. The TMC22191 can be programmed to assign any of its input sources (RGB, YCrCb, CVBS bus, Overlay bits) to any of the four layers.

The ability to combine various video sources into a 4-layer composite image is a very powerful tool in the production of live video. The TMC22191 performs layering operations entirely in the digital domain, enabling precise digital control.

A 4-Layer Example

For this layering example, a BACKGROUND image is generated. This image comprises shaded matte levels varying from black at the top of the screen to white at the bottom. This could just as well be a color image which will be seen wherever no other image appears through the layering process.

The MIDGROUND image comprises a happy face superimposed over a white rectangle. Only the happy face and the white rectangle are of interest for this image and therefore, the portion of the image outside that area will be replaced by the BACKGROUND image when MIDGROUND is keyed over BACKGROUND. A key signal is generated on a pixel-by-pixel basis. It indicates which image is active. The key signal for keying MIDGROUND over BACKGROUND is shown to the right of the MIDGROUND image. This represents a single bit signal mapped over the image. When the signal is black (logic LOW), the MIDGROUND image is active, when it is white (logic HIGH), the BACKGROUND is active.

The results of layering MIDGROUND over BACKGROUND images are shown in the 2-layer composite image Figure 19.

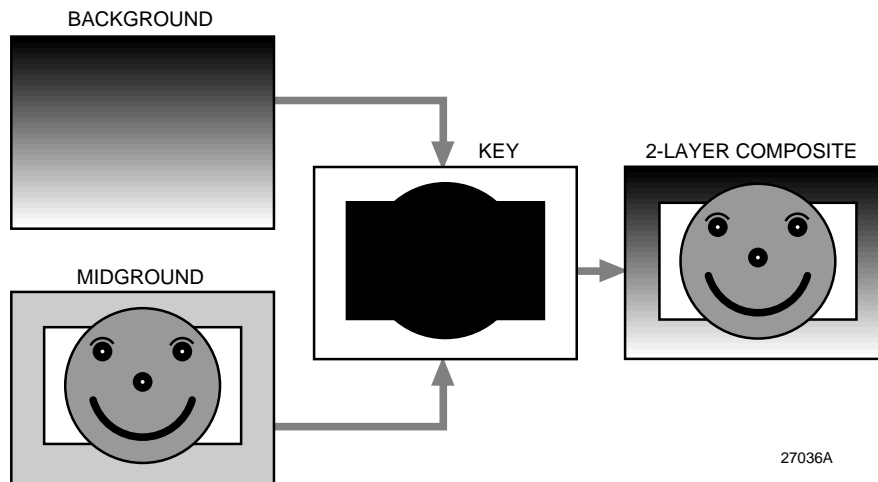
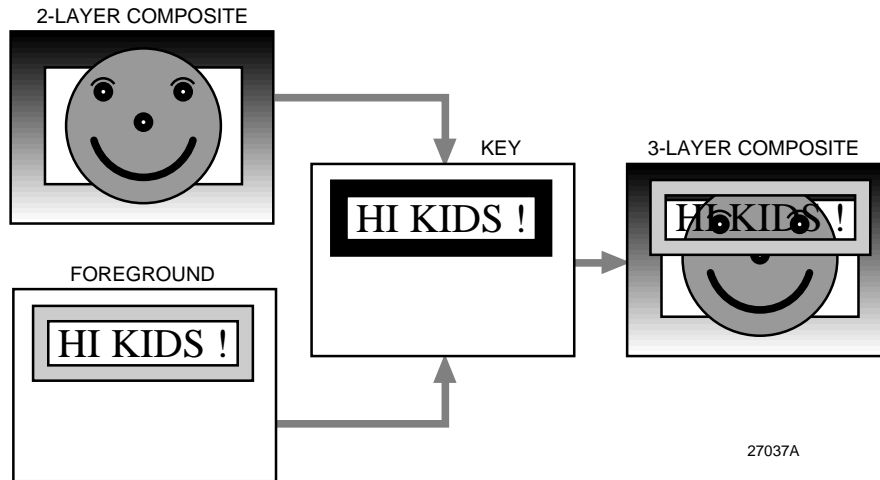

Figure 19. 2-Layer Image Construction

A FOREGROUND image comprises a shaded matte rectangle with "HI KIDS !" alpha characters in its center. This is to be superimposed over the previous 2-layer composite image. The key signal needed for superimposing FOREGROUND over other images is shown to the right of the FOREGROUND image. This represents a single bit signal mapped over the image. When the signal is black (logic LOW), the

FOREGROUND image is active, when it is white (logic HIGH), the composite image is active.

A new 3-layer composite image, FOREGROUND over MIDGROUND over BACKGROUND, is shown in Figure 20.



27037A

Figure 20. Adding a 3rd Layer

A DOWNSTREAM KEY image comprises the white alpha characters "HAPPY FACE", and black alpha characters "Time". This is to be superimposed over the previous 3-layer composite image. The key signal needed for superimposing DOWNSTREAM KEY image over the other composite images is shown to the right. This represents a single bit signal mapped over the image. When the signal is black (logic LOW), the DOWNSTREAM KEY image is active, when it is white (logic HIGH), the previous composite image is active.

The final 4-layer composite image, DOWNSTREAM KEY over FOREGROUND over MIDGROUND over BACKGROUND, is shown in Figure 21.

In this illustration, all four source images are static (not moving). The images input to the TMC22191 can just as well be "live" (from video camera or VCR sources) as long as:

- Data from those sources is in an input format that the TMC22191 can accept, and
- The sources either synchronize the TMC22191 (Genlock mode) or are synchronized by the TMC22191 (Master or Slave mode).

Key signals may be generated external to the TMC22191 (Hardware Keying) and use the KEY input pin for control. Key signals may also be generated within the TMC22191 (Data Keying) by the comparison of input color data with color data stored in the TMC22191.

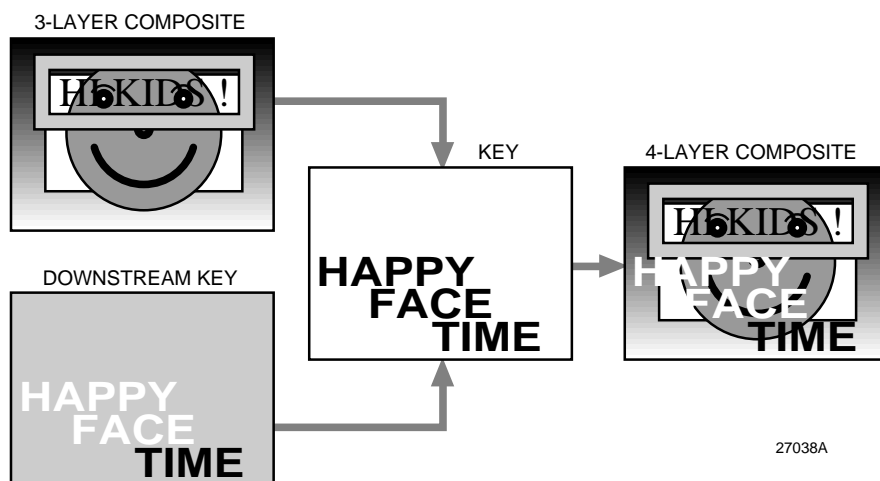

27038A

Figure 21. Adding a 4th Layer

2-Layer Keying with the TMC22091

The TMC22091 facilitates the keying of PD port input data over the CVBS bus input data. Keying is controlled on a pixel-by-pixel basis by either the KEY input pin or the internal Data Key. The first two layers in the previous 4-Layer Example apply to the TMC22091. The result of keying is an effect where a MIDGROUND source image (i.e. Happy Face from PD data) is superimposed over a BACKGROUND source image (i.e. variable matte color from CVBS data).

Assigning Video Sources to Layers with the TMC22191

Digital video inputs to the TMC22191 (PD, CVBS, Overlay) are assigned to the four layers by choosing one of the 16 modes of the Layering Control Register. OVERLAY is always keyed (switched on a pixel-by-pixel basis from active to transparent) by the OL4-0 inputs. OVERLAY can not be programmed to the BACKGROUND layer. The CVBS digital video bus can be assigned to any of the four layers and is keyed by the KEY input signal or internal Data Key. In modes 0 thru 7, the CLUTs are not bypassed and the BYPASS input is ignored.

Table 14. Layer Assignments, Image Sources, and Keying Controls (TMC22191)

LCR 04	Background		Midground		Foreground		Downstream Key	
	LAYMODE	Image Source	Image Source	Keying Control	Image Source:	Keying Control	Image Source:	Keying Control
0	PD(YCbCr, RGB, CI)	CVBS	KEY or Data Key	—	—	—	—	
1	PD(YCbCr, RGB, CI)	CVBS	KEY or Data Key	OVERLAY	OL4-0	—	—	
2	PD(YCbCr, RGB, CI)	CVBS	KEY	PD(YCbCr, RGB, CI)	Data Key	OVERLAY	OL4-0	
3	PD(YCbCr, RGB, CI)	CVBS	KEY	PD(YCbCr, RGB, CI)	Data Key	OVERLAY	OL4-0	
4	CVBS	OVERLAY	OL4-0	PD(YCbCr, RGB, CI)	KEY or Data Key	—	—	
5	CVBS	PD(YCbCr, RGB, CI)	KEY or Data Key	OVERLAY	OL4-0	—	—	
6	PD(YCbCr, RGB, CI)	CVBS	KEY	OVERLAY	OL4-0	PD(YCbCr, RGB, CI)	Data Key	
7	PD(YCbCr, RGB, CI)	CVBS	KEY	OVERLAY	OL4-0	PD(YCbCr, RGB, CI)	Data Key	
8	PD(YCbCr, CI)	CVBS	KEY or Data Key	—	—	—	—	
9	PD(RGB)	PD(YCbCr, CI)	BYPASS	CVBS	KEY or Data Key	OVERLAY	OL4-0	
A	PD(RGB)	CVBS	KEY or Data Key	PD(YCbCr, CI)	BYPASS	OVERLAY	OL4-0	
B	PD(RGB)	CVBS	KEY or Data Key	OVERLAY	OL4-0	PD(YCbCr, CI)	BYPASS	
C	PD(RGB)	PD(YCbCr, CI)	BYPASS	OVERLAY	OL4-0	CVBS	KEY or Data Key	
D	CVBS	PD(RGB)	KEY	PD(YCbCr, CI)	BYPASS	OVERLAY	OL4-0	
E	CVBS	OVERLAY	OL4-0	PD(RGB)	KEY	PD(YCbCr, CI)	BYPASS	
F	PD(RGB)	OVERLAY	OL4-0	CVBS	KEY or Data Key	PD(YCbCr, CI)	BYPASS	

Notes:

- For LAYMODE = 0 to 7, Pixel Data always passes through the CLUTs. FORMAT, INMODE, and the BYPASS pin selects the input format for PD23-0 according to Table 6.
- For LAYMODE = 8 to F and BYPASS = HIGH, Data Key is disabled.
- Asserting the signal listed under "Keying Control:" enables the corresponding "Signal Source:". Signals with "—" are asserted by a logic LOW.

Hardware Keying

The KEY input switches the COMPOSITE D/A converter input from the luminance and chrominance combiner output to the CVBS data bus on a pixel-by-pixel basis. This is a "soft" switch, executed over four PXCK periods to minimize out-of-band spurious signals. The video signal from the CVBS bus can only present on the COMPOSITE output. The CHROMA and LUMA outputs continue to present encoded PD port data when CVBS is active.

Hardware keying is enabled by the Key Control Register bit 6. Normally, keying is only effective during the Active Video portion of the waveform as determined by the VA registers 15 and 18. The Horizontal Blanking interval is generated by the encoder state machine even if the KEY signal is held HIGH through Horizontal Blanking. However, it is possible to allow digital Horizontal Blanking to be passed through from the CVBS bus to the COMPOSITE output by setting

Key Control Register bit 5 HIGH. In this mode, KEY is always active, and may be exercised at will.

The KEY input is registered into the encoder just like Pixel Data is clocked into the PD port. It may be considered a 25th Pixel Data bit. It is internally pipelined, so the midpoint of the key transition occurs at the output of the pixel that was input at the same time as the KEY signal.

Data Keying

Data Keying internally generates a Key signal that acts exactly as the external KEY signal. There are three Key Value Registers 05, 06, and 07 that are matched against the input data to the three tables in the CLUT. These tables are designated D, E, and F. They contain different information depending on the input mode selected as shown in Table 16.

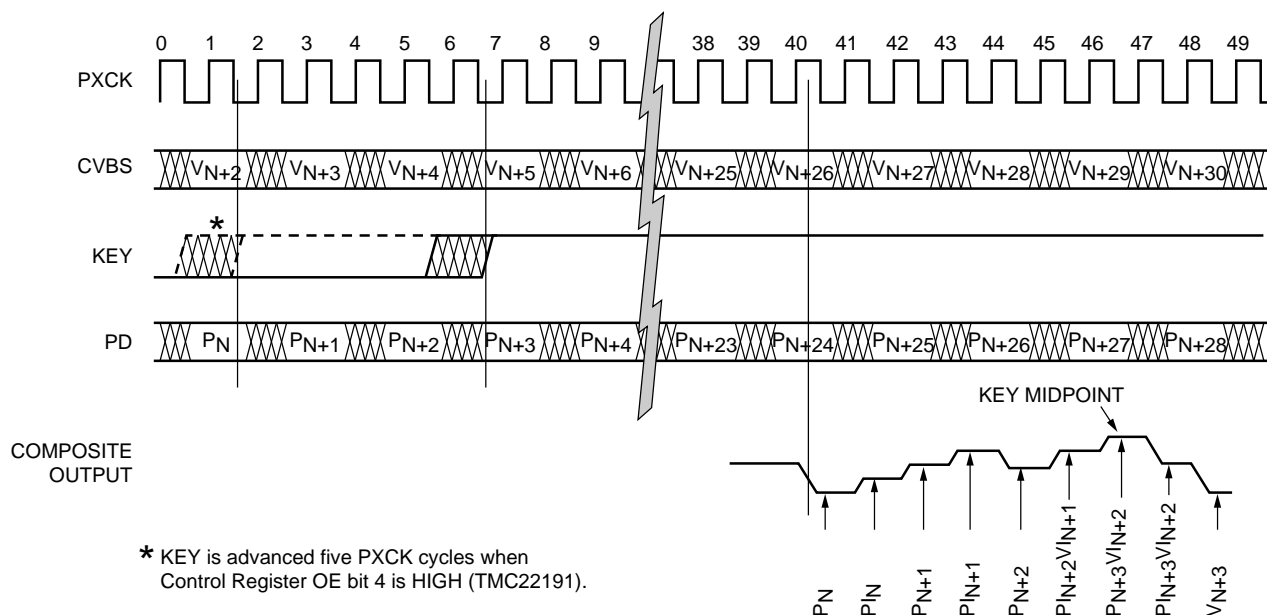

Figure 22. Hardware Keying

The key registers may be individually enabled using bits 3,2,1 of the Key Control Register. Bit 4 of the same register enables/disables Data Keying in its entirety. Data Keying and Hardware Keying are logically ORed: when both are enabled, either one will result in a key switch to the CVBS channel.

The key comparison is based on the input data to the tables in the CLUT. When operating in color-index mode, all three tables receive the same input value, so any one of the three registers is sufficient to identify a key value. The outputs of all enabled key registers are ANDed to produce the KEY signal. If more than one key register are enabled and their key values are not identical, no key will be generated.

Table 16. Table D, E, F Contents

Mode	Table D	Table E	Table F
GBR	Green	Blue	Red
RGB	Red	Green	Blue
YCBCR	Y	CB	CR
CI	CI	CI	CI

Genlock Interface

The TMC22x91 can process digital composite video connected to its CVBS port. It has been designed to couple tightly with the companion TMC22071 Genlocking Video Digitizer, but it will work with other sources as well.

The digital composite video has to be in standard 8-bit binary format at a $PXCK/2$ rate. Synchronization with the internal $PXCK/2$ is established by the phasing of the \overline{GHSYNC} input, as shown in Figures 24 and 25.

Subcarrier frequency and phase data are transmitted to the encoder over the CVBS bus as 4-bit nibbles on CVBS3-0 during the horizontal sync period. Field identification is also required for the TMC22x91 internal sync generator. The 14th nibble of the sequence contains no relevant data.

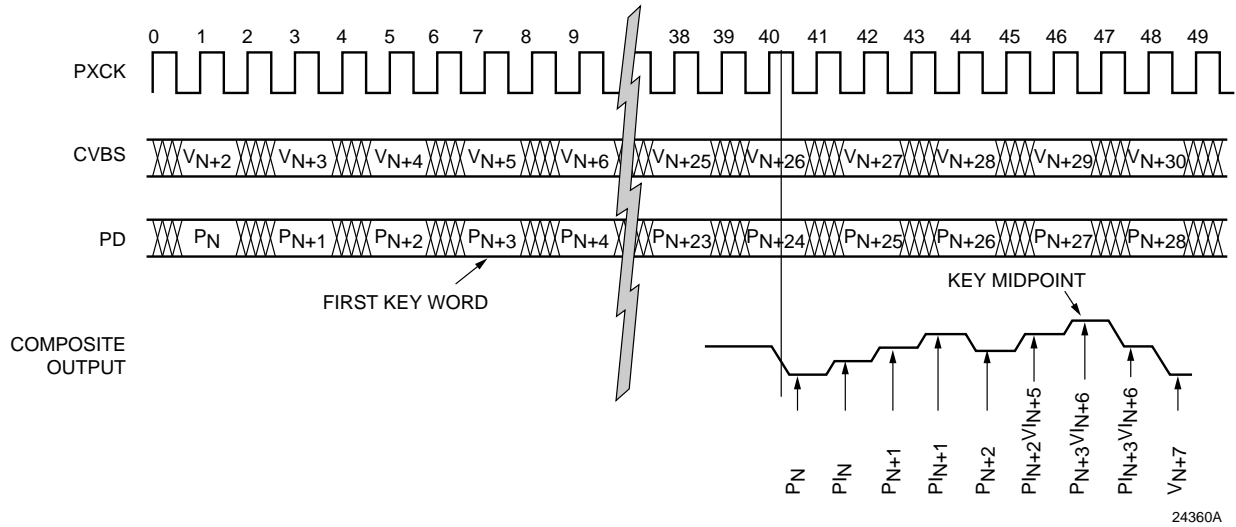

Figure 23. Data Keying

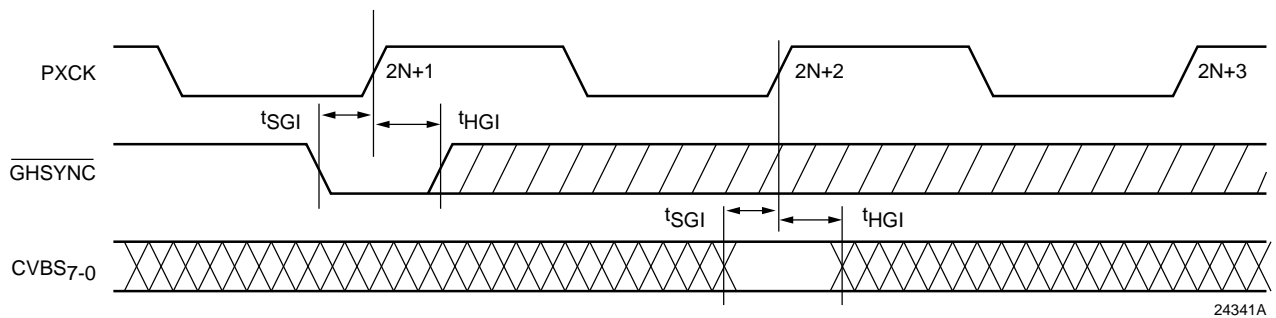

Figure 24. Genlock Interface Timing

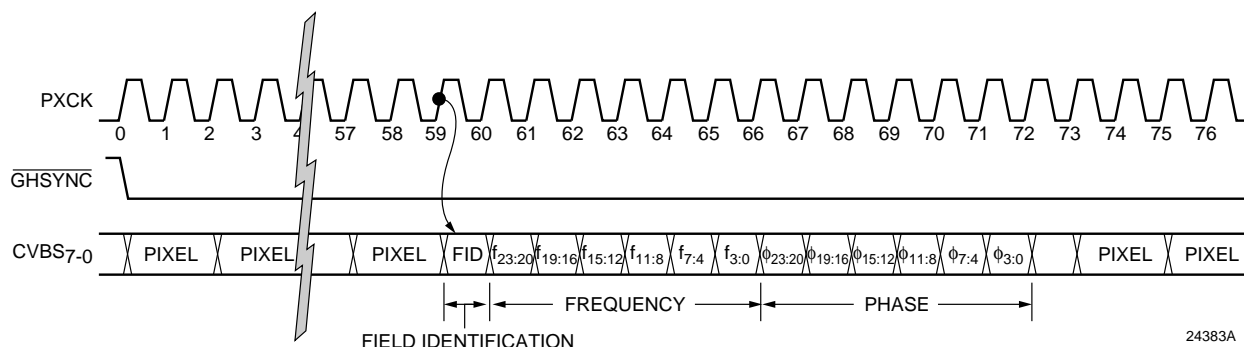

Figure 25. Frequency/Phase Data Transfer

Filtering

The TMC22x91 incorporates internal digital filters to establish appropriate bandwidths and simplify external analog filter designs.

Color-Difference Low-Pass Filters

The color-difference low-pass filters in the TMC22x91 establish chrominance bandwidths which meet the specifications outlined in CCIR Report 624-3, Table II, Item 2.6, for system I over a range of pixel rates from 12.27 Mpps to 14.75 Mpps. Equal bandwidth is established for both color-difference channels.

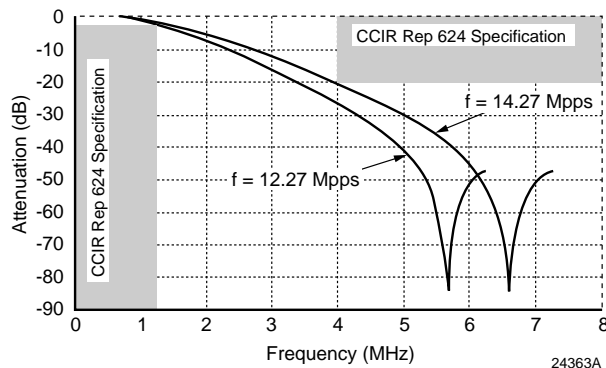

Figure 26. Color-Difference Low-Pass Filter Response

Interpolation Filters

The Chroma Modulator output and the luminance data path are digitally filtered with sharp-cutoff low-pass interpolation filters. These filters ensure that aliased subcarrier, chrominance, and luminance frequencies are sufficiently suppressed in the frequency band above base-band video and below the pixel frequency ($f_s/4$ to $3f_s/4$, where f_s is the PXCK frequency).

Since these are fixed-coefficient digital filters, their filter characteristics depend upon clock rate. Figures 26 and 27 show the frequency response for two pixel rates, 12.27 MHz and 14.75 MHz.

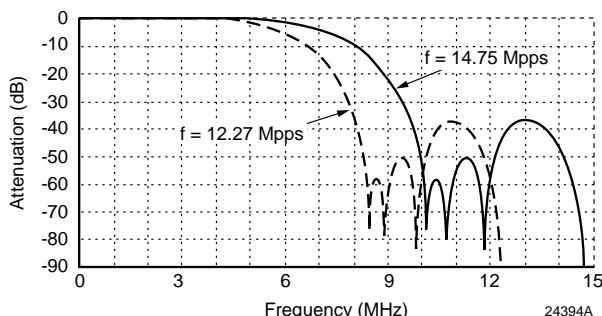

Figure 27. Chroma Modulator and Luminance Interpolation Filter Full Spectrum Response

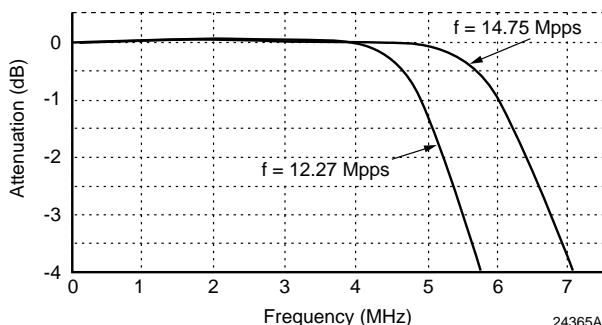

Figure 28. Chroma Modulator and Luminance Interpolation Filter Passband Detail

All digital-to-analog reconstruction systems exhibit a high frequency roll-off as a result of the zero-order hold characteristic of D/A converters. This response is commonly referred to as a $\sin(x)/x$ response. It is a function of the sampling rate of the output D/A.

The digital interpolation filters in TMC22x91 convert the data stream to a sample rate of twice the pixel rate. As shown in Figures 27 and 28, the filters decrease the $\sin(x)/x$ rolloff and the output spectrum between $f_S/4$ and $3f_S/4$ contains very little energy. Since there is so little signal energy in this frequency band, the demands placed on the output reconstruction filter are greatly reduced. The output filter needs to be flat to $f_S/4$ and have good rejection at $3f_S/4$. The relaxed requirements greatly simplify the design of a filter with good phase response and low group delay distortion. A small amount of peaking may be used to compensate residual $\sin(x)/x$ rolloff.

JTAG Test Interface

The JTAG test port accesses registers at every digital I/O pin except the JTAG test port pins. Table 16 shows the sequence of the test registers. The register number (Reg) indicates the order in which the register data is loaded and read (Reg 1 is loaded and read first, therefore it is at the end of the serial path). The scan path is 59 registers long. The six TEST pins of the TMC22091 function as JTAG registers.

The JTAG port is a 4-line interface, following IEEE Std. 1149.1-1990 specifications. The Test Data Input (TDI) and Test Mode Select (TMS) inputs are referred to the rising edge of the Test Clock (TCK) input. The Test Data Output (TDO) is referred to the falling edge of TCK.

Table 16. JTAG Interface Connections

Reg	Pin	Signal	Reg	Pin	Signal	Reg	Pin	Signal
1	28	$\overline{\text{BYPASS}}$ (TEST)	21	62	PD13	41	2	CVBS ₁
2	29	OL ₄ (TEST)	22	63	PD12	42	3	CVBS ₀
3	44	CVBS ₇	23	66	PD11	43	4	KEY
4	45	CVBS ₆	24	67	PD10	44	5	$\overline{\text{RESET}}$
5	46	CVBS ₅	25	68	PD9	45	6	$\overline{\text{CS}}$
6	47	CVBS ₄	26	69	PD8	46	7	R/ $\overline{\text{W}}$
7	48	OL ₃ (TEST)	27	70	PD7	47	8	A ₁
8	49	OL ₂ (TEST)	28	71	PD6	48	9	A ₀
9	50	OL ₁ (TEST)	29	72	PD5	49	11	PDC
10	51	OL ₀ (TEST)	30	73	PD4	50	12	$\overline{\text{VHSYNC}}$
11	52	PD23	31	74	PD3	51	13	$\overline{\text{VVSNC}}$
12	53	PD22	32	75	PD2	52	14	D7
13	54	PD21	33	76	PD1	53	15	D6
14	55	PD20	34	77	PD0	54	16	D5
15	56	PD19	35	78	LDV	55	17	D4
16	57	PD18	36	79	PXCK	56	18	D3
17	58	PD17	37	82	$\overline{\text{GVSYNC}}$	57	19	D2
18	59	PD16	38	83	$\overline{\text{GHSYNC}}$	58	20	D1
19	60	PD15	39	84	CVBS ₃	59	21	D0
20	61	PD14	40	1	CVBS ₂			

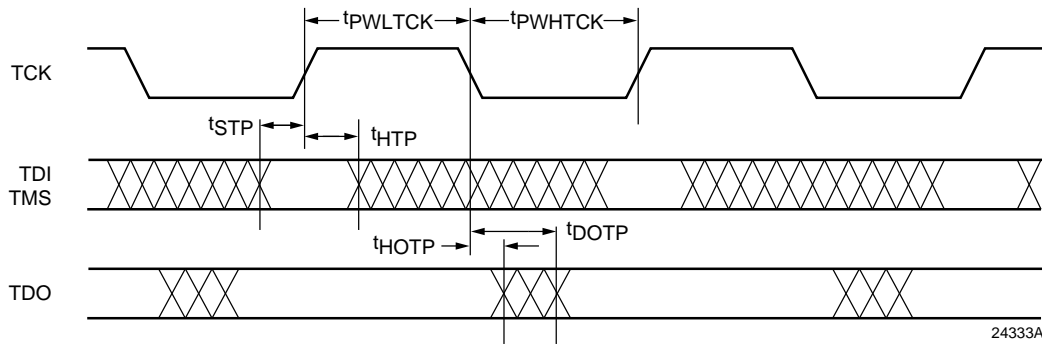

Figure 29. JTAG Test Port Timing

Equivalent Circuits

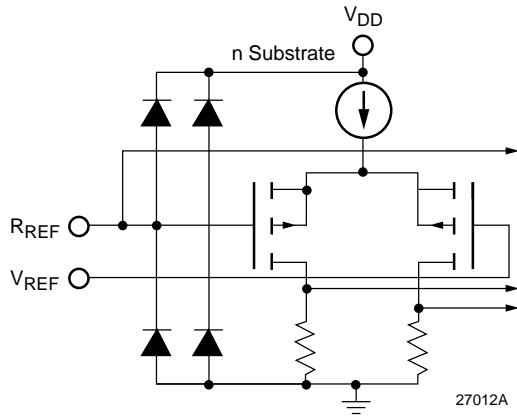

Figure 30. Equivalent Analog Input Circuit

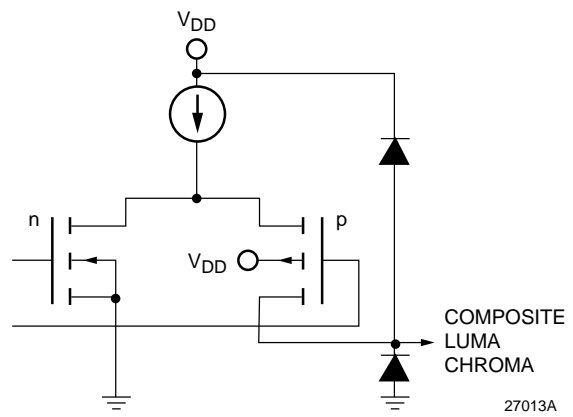

Figure 31. Equivalent Analog Output Circuit

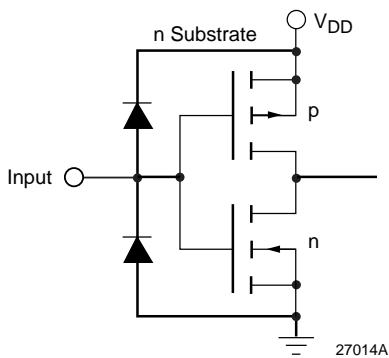

Figure 32. Equivalent Digital Input Circuit

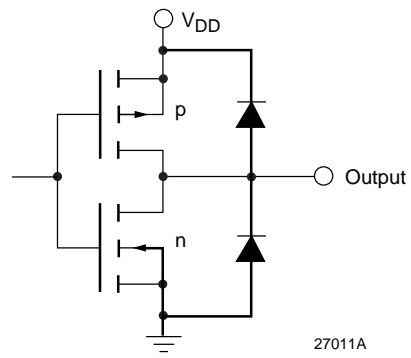

Figure 33. Equivalent Digital Output Circuit

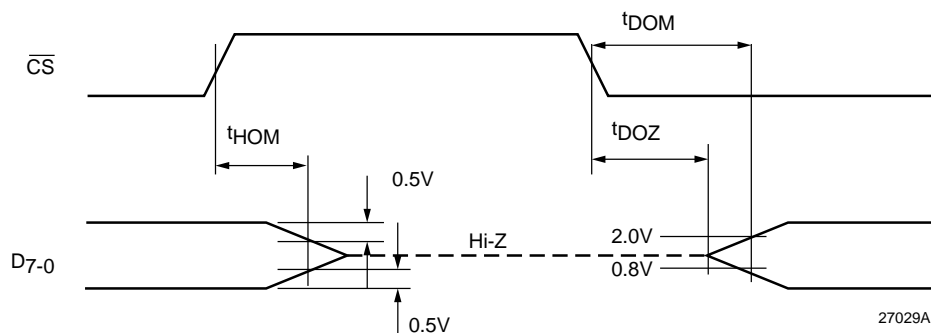

Figure 34. Transition Levels for Three-State Measurements

Absolute Maximum Ratings (beyond which the device may be damaged)¹

Parameter	Min.	Max.	Unit
Power Supply Voltage	-0.5	7.0	V
Digital Inputs			
Applied Voltage ²	-0.5	$V_{DD}+0.5$	V
Forced Current ^{3,4}	-20.0	20.0	mA
Digital Outputs			
Applied Voltage ²	-0.5	$V_{DD}+0.5$	V
Forced Current ^{3,4}	-20.0	20.0	mA
Short Circuit Duration (Single output in HIGH state to GND)		1	second
Analog Output Short Circuit Duration (Single output to GND)	Infinite		
Temperature			
Operating, ambient	-20	110	°C
Operating, junction, plastic package		140	°C
Lead, soldering (10 seconds)		300	°C
Vapor phase soldering (1 minute)		220	°C
Storage	-65	150	°C

Notes:

1. Absolute maximum ratings are limiting values applied individually while all other parameters are within specified operating conditions. Functional operation under any of these conditions is NOT implied.
2. Applied voltage must be current limited to specified range, and measured with respect to GND.
3. Forcing voltage must be limited to specified range.
4. Current is specified as conventional current, flowing into the device.

Operating Conditions

Parameter		Min.	Nom.	Max.	Units
VDD	Power Supply Voltage	4.75	5.0	5.25	V
VIH	Input Voltage, Logic HIGH				
	TTL Compatible Inputs, all but TCK	2.0		VDD	V
	TTL Compatible Input TCK	2.5		VDD	V
	CMOS Compatible Inputs	(2/3)VDD		VDD	V
VIL	Input Voltage, Logic LOW				
	TTL Compatible Inputs	GND		0.8	V
	CMOS Compatible Inputs	GND		(1/3)VDD	V
IOH	Output Current, Logic HIGH			-2.0	mA
IOL	Output Current, Logic LOW			4.0	mA
VREF	External Reference Voltage		1.235		V
IREF	D/A Converter Reference Current, VREF = Nom. (IREF = VREF / RREF, flowing out of the RREF pin)	2.1	3.15	4.4	mA
RREF	Reference Resistor, VREF = Nom.	281	392	588	Ω
ROUT	Total Output Load Resistance		37.5		Ω
TA	Ambient Temperature, Still Air	0		70	°C
Pixel Interface					
fPXL	Pixel Rate	12.27		15	Mpps
fPXCK	Master Clock Rate, 2x pixel rate	24.54		30	MHz
tPWHPX	PXCK Pulse Width, HIGH	10			ns
tPWLPX	PXCK Pulse Width, LOW	10			ns
For PD, $\overline{VVS\text{Y}N\text{C}}$, $\overline{VHS\text{Y}N\text{C}}$, PDC, KEY					
tSP	Setup Time	12			ns
tHP	Hold Time, PD and KEY	0			ns
tHP	Hold Time, PDC, $\overline{VHS\text{Y}N\text{C}}$, $\overline{VVS\text{Y}N\text{C}}$	5			ns
tXL	Delay Time, LDV	10			ns
tPWHLDV	LDV Pulse Width, HIGH	15			ns
tPWLLDV	LDV Pulse Width, LOW	10			ns
tPWL VH	$\overline{VHS\text{Y}N\text{C}}$ Pulse Width, LOW	6		15	PXCK periods
tPWHV V	$\overline{VVS\text{Y}N\text{C}}$ Pulse Width, LOW	0.5		3	H
Genlock Interface					
tSGI	Setup Time, $\overline{GHS\text{Y}N\text{C}}$, $\overline{GVS\text{Y}N\text{C}}$, CVBS	10			ns
tHGI	Hold Time, $\overline{GHS\text{Y}N\text{C}}$, $\overline{GVS\text{Y}N\text{C}}$, CVBS	0			ns
Microprocessor Interface					
tPWLCS	\overline{CS} Pulse Width, LOW	55			ns
tPWHCS	\overline{CS} Pulse Width, HIGH	30			ns
tSA	Address Setup Time	10			ns
tHA	Address Hold Time	0			ns
tSD	Data Setup Time (write)	15			ns
tHD	Data Hold Time (write)	0			ns

Operating Conditions (continued)

Parameter		Min.	Nom.	Max.	Units
tSR	Reset Setup Time	24			ns
tHR	Reset Hold Time	2			ns
JTAG Interface					
fTCK	Test Clock (TCK) Rate			20	MHz
tpWLTCK	TCK Pulse Width, LOW	10			ns
tpWHTCK	TCK Pulse Width, HIGH	25			ns
tSTP	Test Port Setup Time, TDI, TMS	10			ns
tHTP	Test Port Hold Time, TDI, TMS	3			ns

Note:

1. Timing reference points are at the 50% level.

Electrical Characteristics

Parameter		Conditions	Min.	Typ.	Max.	Units
I _{DD}	Power Supply Current ¹	V _{DD} = Max, f _{PXCK} = 30MHz		250	300	mA
I _{DDQ}	Power Supply Current ¹ (D/A disabled)	V _{DD} = Max, f _{PXCK} = 30MHz			60	mA
V _{RO}	Voltage Reference Output		0.988	1.235	1.482	V
I _{BR}	Input Bias Current, V _{REF}	V _{REF} = Nom		100		μA
I _{IH}	Input Current, Logic HIGH	V _{DD} = Max, V _{IN} = V _{DD}			10	μA
I _{IL}	Input Current, Logic LOW	V _{DD} = Max, V _{IN} = 0V			-10	μA
V _{OH}	Output Voltage, Logic HIGH	I _{OH} = Max	2.4			V
V _{OL}	Output Voltage, Logic LOW	I _{OL} = Max			0.4	V
I _{OZH}	Hi-Z Leakage current, HIGH	V _{DD} = Max, V _{IN} = V _{DD}			10	μA
I _{OZL}	Hi-Z Leakage current, LOW	V _{DD} = Max, V _{IN} = GND			-10	μA
C _I	Digital Input Capacitance	T _A = 25°C, f = 1MHz		4	10	pF
C _O	Digital Output Capacitance	T _A = 25°C, f = 1MHz		10		pF
V _{OC}	Video Output Compliance Voltage		-0.3		2.0	V
R _{OUT}	Video Output Resistance			15		kΩ
C _{OUT}	Video Output Capacitance	I _{OUT} = 0 mA, f = 1 MHz		15	25	pF

Note:

1. Typical I_{DD} with V_{DD} = +5.0 Volts and T_A = 25°C, Maximum I_{DD} with V_{DD} = +5.25 Volts and T_A = 0°C.

Switching Characteristics

Parameter		Conditions	Min.	Typ.	Max.	Units
PIPES	Pipeline Delay ³	PD to Analog Out	44	44	44	PXCK periods
tDOZ	Output Delay, \overline{CS} to low-Z		6		23	ns
tDOM	Output Delay, \overline{CS} to Data Valid ⁴				100	ns
tHOM	Output Hold Time, \overline{CS} to hi-Z		10			ns
tDOTP	Output Delay, TCK to TDO Valid				30	ns
tHOTP	Output Hold Time, TCK to TDO Valid			5		ns
tDOS	Output Delay	PXCK to \overline{VHSYNC} , \overline{VVSNC} , PDC			25	ns
tR	D/A Output Current Risettime	10% to 90% of full-scale		2		ns
tF	D/A Output Current Falltime	90% to 10% of full-scale		2		ns
tDOV	Analog Output Delay			20		ns

Notes:

1. Timing reference points are at the 50% level.
2. Analog CLOAD < 10 pF, D7-0 load < 40 pF.
3. Pipeline delay, with respect to PXCK, is a function of the phase relationship between the internally generated PCK (PXCK/2) and PXCK, as established by the hardware reset.
4. tDOM = 1 PXCK + 54 ns = 100 ns worst-case at PXCK = 24.54 MHz.

System Performance Characteristics

Parameter		Conditions	Min.	Typ.	Max.	Units
RES	D/A Converter Resolution		10	10	10	Bits
ELI	Integral Linearity Error				0.25	%
ELD	Differential Linearity Error				0.20	%
EG	Gain Error				±10	% FS
dp	Differential Phase	PXCK = 24.54 MHz, 40 IRE Ramp ³		0.5		degree
dg	Differential Gain	PXCK = 24.54 MHz, 40 IRE Ramp ³		0.9		%
SKEW	CHROMA to LUMA Output Skew			0	2	ns
PSRR	Power Supply Rejection Ratio	CCOMP = 0.1 μF, f = 1kHz		0.5		%/ %VDD

Notes:

1. TTL input levels are 0.0 and 3.0 Volts, 10%-90% rise and fall times <3 ns.
2. Analog CLOAD < 10 pF, D7-0 load < 40 pF.
3. NTSC

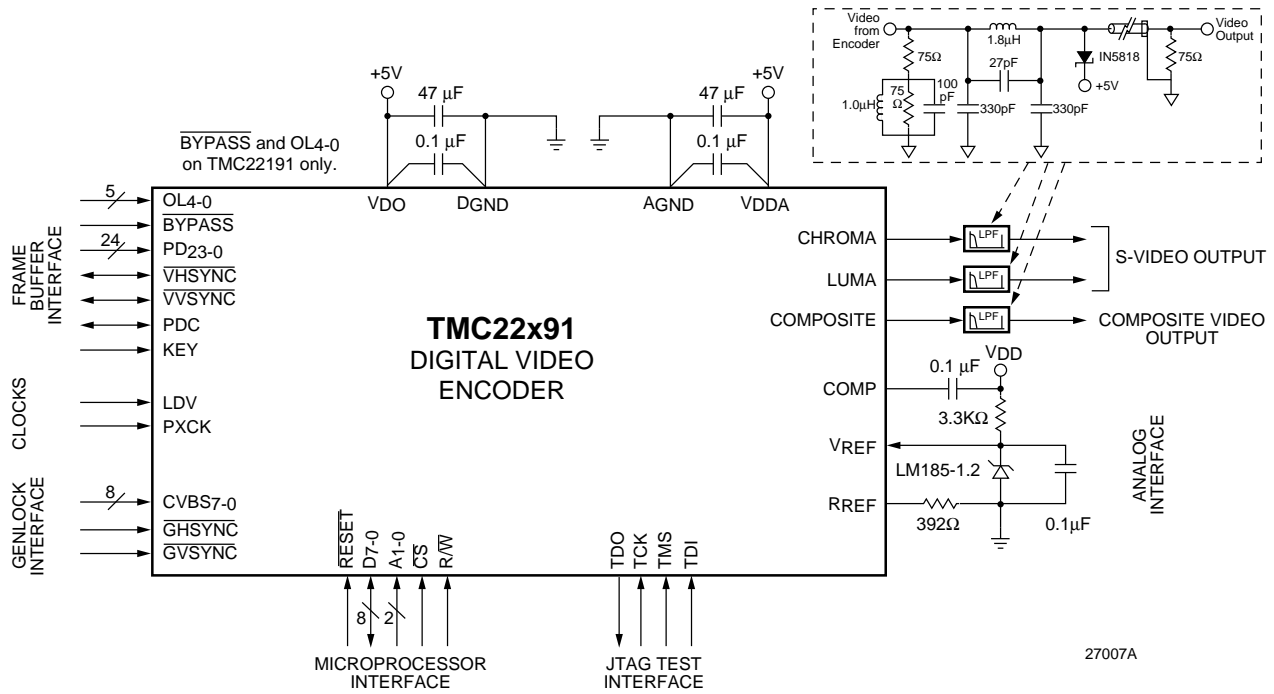

Figure 35. Recommended Interface Circuit

Applications Discussion

The TMC22x91 is a complex mixed-signal VLSI circuit. It converts digital video signals at clock rates of up to 30 MHz to analog video outputs. A recommended circuit connection is shown in Figure 35.

References

The circuit shown in Figure 35 uses a stable external 1.235V voltage reference. To use the internal voltage reference, simply delete the 3.3kΩ resistor and the LM185-12. A simple voltage divider from the power supply should NOT be used, as any variations in power supply voltage would appear directly on the video outputs.

Filtering

An simple low-pass output reconstruction filter is shown in Figure 36. This filter is located in the video signal path after the COMPOSITE, LUMA, and CHROMA outputs. The value of RREF may be varied to make up for the filter loss.

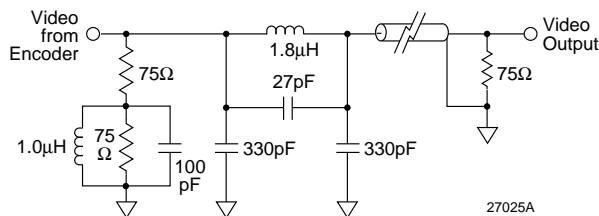

Figure 36. Recommended Output Reconstruction Filter

Interface to the TMC22071 Genlocking Video Digitizer

The TMC22x91 Digital Video Encoder has been designed to directly interface to the TMC22071 Genlocking Video Digitizer. An interface circuit is shown in Figure 37. The microprocessor interface for TMC22x91 and TMC22071 are similar. The R/W, RESET, D0 and A0 signals from the host microprocessor are shared by the TMC22x91 and TMC22071. The CS signals are separately driven from the microprocessor bus.

Grounding Strategy

The TMC22x91 has distinctly separate analog and digital circuits. To minimize digital crosstalk into the analog signals, the power supplies and grounds are provided over separate pins. In general, the best results are obtained by connecting all grounds to a ground plane. Power supply pins should be individually decoupled at the pin.

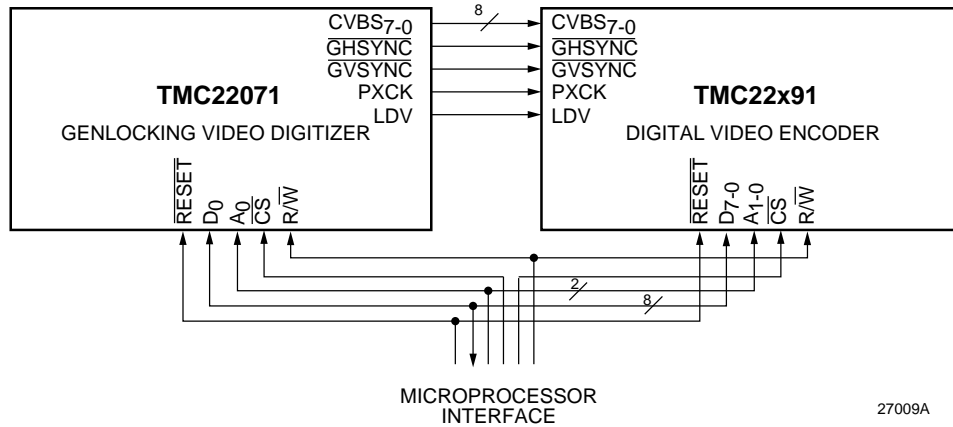

Figure 37. TMC22x91-to-TMC22071 Interface Circuit

Printed Circuit Board Layout

Designing with high-performance mixed-signal circuits demands printed circuits with ground planes. Overall system performance is strongly influenced by the board layout. Capacitive coupling from digital to analog circuits may result in poor picture quality. Consider the following suggestions when doing the layout:

- Keep analog traces (COMP, VREF, RREF) as short and as far from all digital signals as possible.
- The power plane for the TMC22x91 should be separate from that which supplies other digital circuitry. A single power plane should be used for all of the VDD pins. If the power supply for the TMC22x91 is the same for the system’s digital circuitry, power to the TMC22x91 should be filtered with ferrite beads and 0.1µF capacitors to reduce noise.
- The ground plane should be solid, not cross-hatched. Connections to the ground plane should be very short.
- Decoupling capacitors should be applied liberally to VDD pins. For best results, use 0.1µF capacitor in parallel with 47µF capacitors. Lead lengths should be minimized. Ceramic chip capacitors are the best choice.
- The PXCK should be handled carefully. Jitter and noise on this clock or its ground reference will translate to noise on the video outputs. Terminate the clock line carefully to eliminate overshoot and ringing.

Microprocessor I/O Operations

Various CLUT Read/Write operations are shown in Table 17. Each step in the table requires a \overline{CS} pulse (falling edge followed by a rising edge) to execute.

For Write operations, R/\overline{W} and A1-0 must conform to setup and hold timing with respect to the falling edge of \overline{CS} . D7-0 must meet setup and hold timing with respect to the rising edge of \overline{CS} . These timing relationships are illustrated in Figure 10. When writing data into an internal register (i.e. CLUT Address Register) an extra \overline{CS} falling edge is required to transfer the input data to that register. This requirement is usually accomplished by executing the next step in the sequence. If there is no planned next step in the sequence, executing a Control Register Read step will meet the requirement and terminate the sequence.

For Read operations, R/\overline{W} and A1-0 must conform to setup and hold timing with respect to the falling edge of \overline{CS} . Read data on D7-0 is initiated by the falling edge of \overline{CS} and terminated by the rising edge of \overline{CS} as shown in Figure 11. When reading Control Registers, valid data appears t_{DOM} after the falling edge of \overline{CS} . When reading CLUT locations, an extra CLUT Read step is needed to set up the CLUT Read sequence. This is accomplished in the table by executing an extra CLUT Read step just before the CLUT Read sequence which returns successive d, e, and f data. CLUT Read sequences must be terminated an extra \overline{CS} falling edge. This requirement is usually accomplished by executing the next I/O step. If there is no planned next step in the sequence, executing a Control Register Read step will meet the requirement and terminate the sequence.

Table 17. CLUT Read/Write Sequences

Step	R/W	A1-0	D7-0	Function
Write Entire CLUT Starting at Address 00				
1	0	01	00	Write 00 into CLUT Address Register.
1	0	01	00	Write 00 into CLUT Address Register.
2	0	11	d1	d1 written into D, CLUT address 00.
3	0	11	e1	e1 written into E, CLUT address 00.
4	0	11	f1	f1 written into F, CLUT address 00.
...	repeat steps 3, 4, 5 until CLUT is full.
767	0	11	d256	d256 written into D, CLUT address FF.
768	0	11	e256	e256 written into E, CLUT address FF.
769	0	11	f256	f256 written into F, CLUT address FF.
770	1	00	xx	Sequence termination.
Write CLUT Location address				
1	0	01	addr	Write addr into the CLUT Address Register.
2	0	11	d1	d1 written into D, CLUT address addr.
3	0	11	e1	e1 written into E, CLUT address addr.
4	0	11	f1	f1 written into F, CLUT address addr.
5	1	00	xx	Sequence termination.
Read CLUT Location address				
1	0	01	addr	Write addr into the CLUT Address Register.
2	1	11	xx	Set up for CLUT Read sequence.
3	1	11	d1	d1 read from D, CLUT address addr.
4	1	11	e1	e1 read from E, CLUT address addr.
5	1	11	f1	f1 read from F, CLUT address addr.
6	1	00	xx	Sequence termination.
Read CLUT Address Register Then Write				
1	1	01	addr	Read CLUT Address Register.
2	0	11	d1	d1 written into D, CLUT address addr.
3	0	11	e1	e1 written into E, CLUT address addr.
4	0	11	f1	f1 written into F, CLUT address addr.
5	1	01	addr+1	Read CLUT Address Register. (terminates Write sequence)
6	0	11	d2	d2 written into D, CLUT address addr+1.
7	0	11	e2	e2 written into E, CLUT address addr+1.
8	0	11	f2	f2 written into F, CLUT address addr+1.
9	1	00	xx	Sequence termination.

Table 17. CLUT Read/Write Sequences (continued)

Step	R/W	A1-0	D7-0	Function
Read/Modify/Write CLUT Location address				
1	0	01	addr	Write addr into the CLUT Address Register.
2	1	11	xx	Set up for CLUT Read.
3	1	11	d1	d1 read from D, CLUT address addr.
4	1	11	e1	e1 read from E, CLUT address addr.
5	1	11	f1	f1 read from F, CLUT address addr.
...	System Modifies d1, e1, f1 to d1', e1', f1'.
6	0	01	addr	Write addr into the CLUT Address Register. (terminates Read sequence)
7	0	11	d1'	d1' written into D, CLUT address addr.
8	0	11	e1'	e1' written into E, CLUT address addr.
9	0	11	f1'	f1' written into F, CLUT address addr.
10	1	00	xx	Sequence termination.

Related Products

- TMC22071 Genlocking Video Digitizer
- TMC2242/2243/2246 Video Filters
- TMC2249 Video Mixer
- TMC2255 Convolver
- TMC2272 Colorspace Converter
- TMC2302 Image Manipulation Sequencer

Notes:

Notes:

Mechanical Dimensions – 84-Lead PLCC Package

Symbol	Inches		Millimeters		Notes
	Min.	Max.	Min.	Max.	
A	.165	.200	4.19	5.08	
A1	.090	.130	2.29	3.30	
A2	.020	—	.51	—	
B	.013	.021	.33	.53	
B1	.026	.032	.66	.81	
D/E	1.185	1.195	30.10	30.35	
D1/E1	1.150	1.158	29.21	29.41	3
D3/E3	1.000 BSC		25.40 BSC		
e	.050 BSC		1.27 BSC		
J	.042	.056	1.07	1.42	2
ND/NE	21		21		
N	84		84		
ccc	—	.004	—	0.10	

Notes:

1. All dimensions and tolerances conform to ANSI Y14.5M-1982.
2. Corner and edge chamfer = 45°.
3. Dimension D1 and E1 do not include mold protrusion. Allowable protrusion is .101" (.25mm).

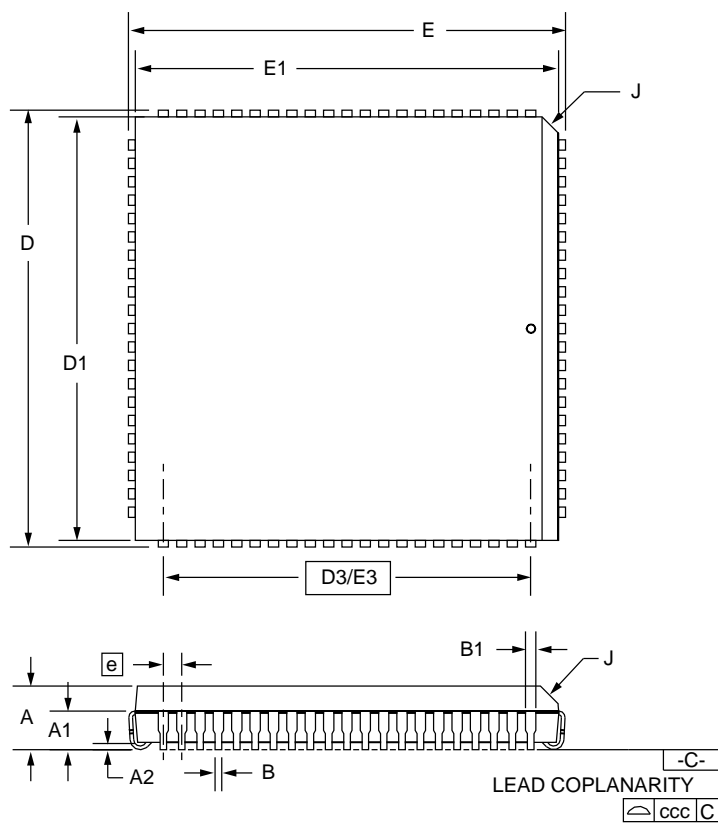

Mechanical Dimensions

100 Lead MQFP Package – 3.2mm Footprint

Symbol	Inches		Millimeters		Notes
	Min.	Max.	Min.	Max.	
A	—	.134	—	3.40	
A1	.010	—	.25	—	
A2	.100	.120	2.55	3.05	
B	.008	.015	.22	.38	3, 5
C	.005	.009	.13	.23	5
D	.904	.923	22.95	23.45	
D1	.783	.791	19.90	20.10	
E	.667	.687	16.95	17.45	
E1	.547	.555	13.90	14.10	
e	.0256 BSC		.65 BSC		
L	.028	.040	.73	1.03	4
N	100		100		
ND	30		30		
NE	20		20		
α	0°	7°	0°	7°	
ccc	—	.004	—	.12	

Notes:

1. All dimensions and tolerances conform to ANSI Y14.5M-1982.
2. Controlling dimension is millimeters.
3. Dimension "B" does not include dambar protrusion. Allowable dambar protrusion shall be .08mm (.003in.) maximum in excess of the "B" dimension. Dambar cannot be located on the lower radius or the foot.
4. "L" is the length of terminal for soldering to a substrate.
5. "B" & "C" includes lead finish thickness.

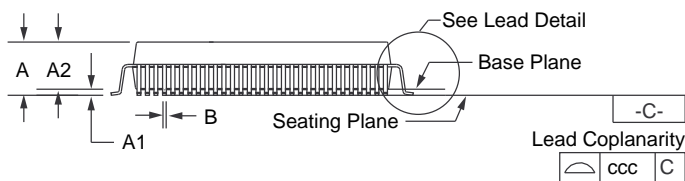
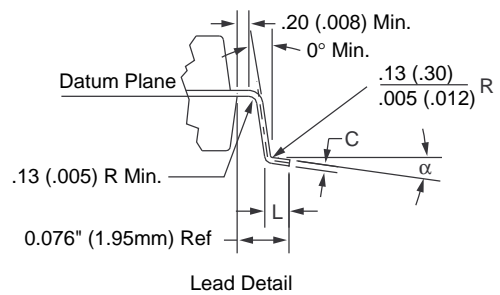
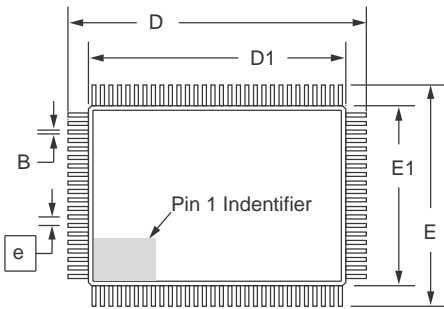

Ordering Information

Product Number	Temperature Range	Screening	Package	Package Marking
TMC22091KHC	T _A = 0°C to 70°C	Commercial	100-Lead MQFP	22091KHC
TMC22091R0C	T _A = 0°C to 70°C	Commercial	84-Lead PLCC	22091R0C
TMC22191KHC	T _A = 0°C to 70°C	Commercial	100-Lead MQFP	22191KHC
TMC22191R0C	T _A = 0°C to 70°C	Commercial	84-Lead PLCC	22191R0C

LIFE SUPPORT POLICY

FAIRCHILD'S PRODUCTS ARE NOT AUTHORIZED FOR USE AS CRITICAL COMPONENTS IN LIFE SUPPORT DEVICES OR SYSTEMS WITHOUT THE EXPRESS WRITTEN APPROVAL OF THE PRESIDENT OF FAIRCHILD SEMICONDUCTOR CORPORATION. As used herein:

1. Life support devices or systems are devices or systems which, (a) are intended for surgical implant into the body, or (b) support or sustain life, and (c) whose failure to perform when properly used in accordance with instructions for use provided in the labeling, can be reasonably expected to result in a significant injury of the user.
2. A critical component in any component of a life support device or system whose failure to perform can be reasonably expected to cause the failure of the life support device or system, or to affect its safety or effectiveness.