

## INPUT/OUTPUT RAIL TO RAIL DUAL CMOS OPERATIONAL AMPLIFIER

- **RAIL TO RAIL** INPUT AND OUTPUT VOLTAGE RANGES
- SINGLE (OR DUAL) SUPPLY OPERATION FROM **2.7V TO 16V** ( $\pm 1.35V$  to  $\pm 8V$ )
- EXTREMELY LOW INPUT BIAS CURRENT : **1pA TYP**
- LOW INPUT OFFSET VOLTAGE : **2mV max.**
- SPECIFIED FOR **600Ω** AND **100Ω** LOADS
- LOW SUPPLY CURRENT : 400μA/Ampli
- SPEED : 1.4MHz - 1.3V/μs
- ESD TOLERANCE : 3KV
- LATCH-UP IMMUNITY
- **SPICE MACROMODEL** INCLUDED IN THIS SPECIFICATION

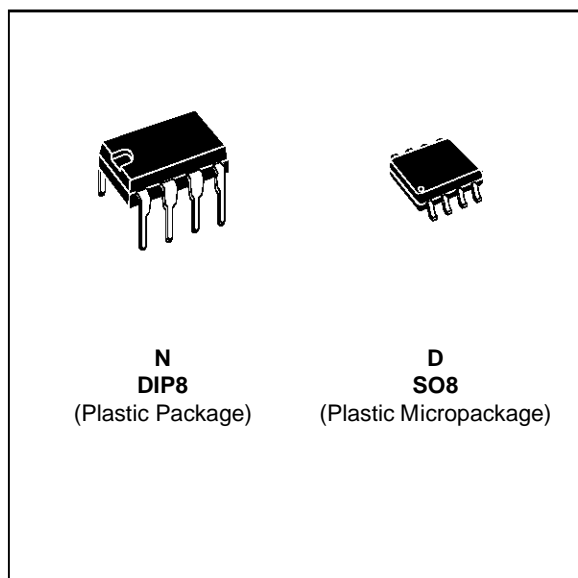

### ORDER CODES

| Part Number  | Temperature Range | Package |   |
|--------------|-------------------|---------|---|
|              |                   | N       | D |
| TS912I/AI/BI | -40, +125°C       | •       | • |

### PIN CONNECTIONS (top view)

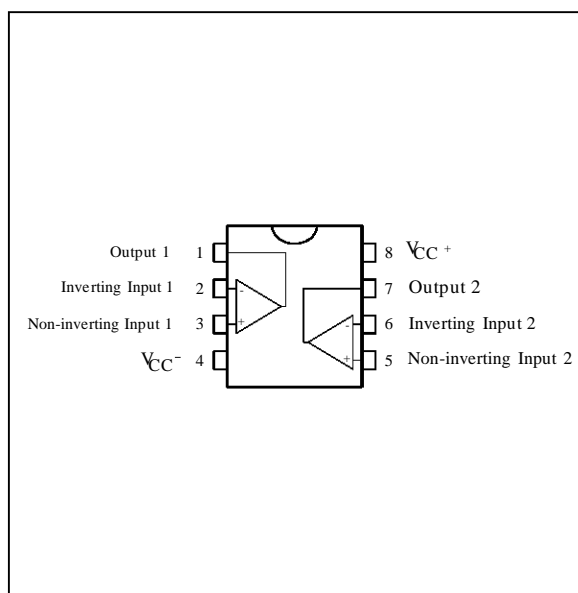

### DESCRIPTION

The TS912 is a RAIL TO RAIL dual CMOS operational amplifier designed to operate with single or dual supply voltage.

The input voltage range  $V_{icm}$  includes the two supply rails  $V_{CC}^+$  and  $V_{CC}^-$ .

The output reaches :

- $V_{CC}^- + 50mV$      $V_{CC}^+ - 50mV$     with  $R_L = 10k\Omega$
- $V_{CC}^- + 650mV$      $V_{CC}^+ - 650mV$     with  $R_L = 600\Omega$

This product offers a broad supply voltage operating range from 2.7V to 16V, a supply current of only 400μA/amp ( $V_{CC} = 10V$ ) and a high output current capability fixed by an internal limitation circuit :

$$I_{source} = 65mA - I_{sink} = 75mA$$

**SCHEMATIC DIAGRAM (1/2 TS912)**

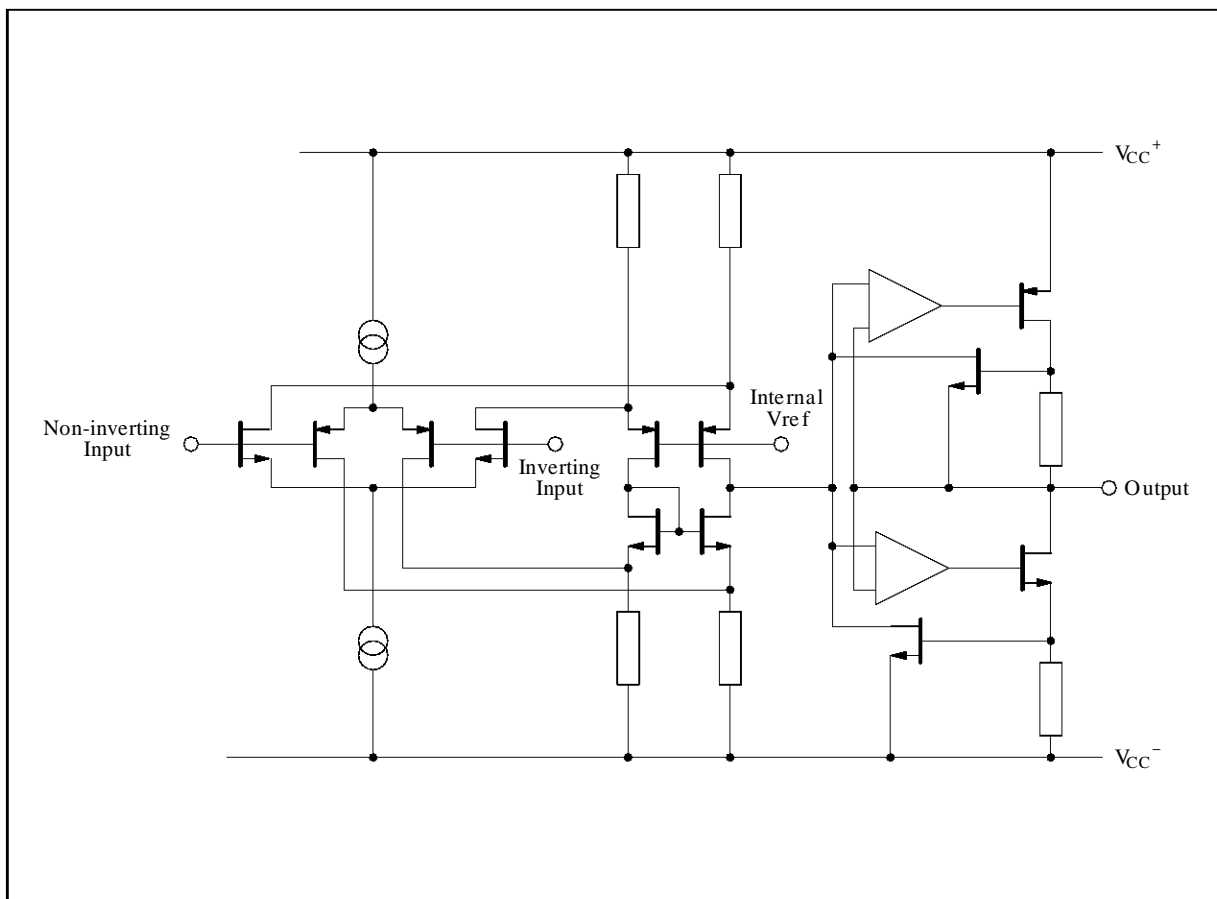

**ABSOLUTE MAXIMUM RATINGS**

| Symbol     | Parameter  | Value       | Unit        |
|------------|--|-------------|-------------|
| $V_{CC}$   | Supply Voltage - (note 1)                            | 18          | V           |
| $V_{id}$   | Differential Input Voltage - (note 2)                | $\pm 18$    | V           |
| $V_i$      | Input Voltage - (note 3)                             | -0.3 to 18  | V           |
| $I_{in}$   | Current on Inputs                                    | $\pm 50$    | mA          |
| $I_o$      | Current on Outputs                                   | $\pm 130$   | mA          |
| $T_{oper}$ | Operating Free Air Temperature Range<br>TS912I/AI/BI | -40 to +125 | $^{\circ}C$ |
| $T_{stg}$  | Storage Temperature                                  | -65 to +150 | $^{\circ}C$ |

- Notes :**
1. All voltage values, except differential voltage are with respect to network ground terminal.
  2. Differential voltages are the non-inverting input terminal with respect to the inverting input terminal.
  3. The magnitude of input and output voltages must never exceed  $V_{CC}^{+} + 0.3V$ .

**OPERATING CONDITIONS**

| Symbol    | Parameter                       | Value                                    | Unit |
|-----------|---------------------------------|--|------|
| $V_{CC}$  | Supply Voltage                  | 2.7 to 16                                | V    |
| $V_{icm}$ | Common Mode Input Voltage Range | $V_{CC}^{-} - 0.2$ to $V_{CC}^{+} + 0.2$ | V    |

**ELECTRICAL CHARACTERISTICS**
 $V_{CC}^+ = 10V$ ,  $V_{CC}^- = 0V$ ,  $R_L, C_L$  connected to  $V_{CC}/2$ ,  $T_{amb} = 25^\circ C$  (unless otherwise specified)

| Symbol          | Parameter  | TS912I/AI/BI  |                                     |  | Unit                   |
|-----------------|--|---|-------------------------------------|--|------------------------|
|                 |  | Min.  | Typ.                                | Max.                                       |                        |
| $V_{io}$        | Input Offset Voltage ( $V_{ic} = V_o = V_{CC}/2$ )<br>$T_{min.} \leq T_{amb} \leq T_{max.}$                                | TS912<br>TS912A<br>TS912B<br>TS912<br>TS912A<br>TS912B  |                                     | 10<br>5<br>2<br>12<br>7<br>3               | mV                     |
| $DV_{io}$       | Input Offset Voltage Drift   |   | 5                                   |  | $\mu V/^\circ C$       |
| $I_{io}$        | Input Offset Current - (note 1)<br>$T_{min.} \leq T_{amb} \leq T_{max.}$   |   | 1                                   | 100<br>200                                 | pA                     |
| $I_{ib}$        | Input Bias Current - (note 1)<br>$T_{min.} \leq T_{amb} \leq T_{max.}$   |   | 1                                   | 150<br>300                                 | pA                     |
| $I_{CC}$        | Supply Current (per amplifier, $A_{VCL} = 1$ , no load)<br>$T_{min.} \leq T_{amb} \leq T_{max.}$                           |   | 400                                 | 600<br>700                                 | $\mu A$                |
| CMR             | Common Mode Rejection Ratio<br>$V_{ic} = 3$ to $7V$ , $V_o = 5V$<br>$V_{ic} = 0$ to $10V$ , $V_o = 5V$                     |   | 60<br>50                            | 90<br>75                                   | dB                     |
| SVR             | Supply Voltage Rejection Ratio ( $V_{CC}^+ = 5$ to $10V$ , $V_o = V_{CC}/2$ )  |   | 60                                  | 90   | dB                     |
| $A_{vd}$        | Large Signal Voltage Gain ( $R_L = 10k\Omega$ , $V_o = 2.5V$ to $7.5V$ )<br>$T_{min.} \leq T_{amb} \leq T_{max.}$          |   | 20<br>15                            | 60   | V/mV                   |
| $V_{OH}$        | High Level Output Voltage ( $V_{id} = 1V$ )<br>$T_{min.} \leq T_{amb} \leq T_{max.}$                                       | $R_L = 100k\Omega$<br>$R_L = 10k\Omega$<br>$R_L = 600\Omega$<br>$R_L = 100\Omega$<br><br>$R_L = 10k\Omega$<br>$R_L = 600\Omega$ | 9.95<br>9.85<br>9<br><br>9.8<br>8.8 | 9.95<br>9.35<br>7.8                        | V                      |
| $V_{OL}$        | Low Level Output Voltage ( $V_{id} = -1V$ )<br>$T_{min.} \leq T_{amb} \leq T_{max.}$                                       | $R_L = 100k\Omega$<br>$R_L = 10k\Omega$<br>$R_L = 600\Omega$<br>$R_L = 100\Omega$<br><br>$R_L = 10k\Omega$<br>$R_L = 600\Omega$ |                                     | 50<br>150<br>800<br>2300<br><br>150<br>900 | mV                     |
| $I_o$           | Output Short Circuit Current ( $V_{id} = \pm 1V$ )   | Source ( $V_o = V_{CC}^-$ )<br>Sink ( $V_o = V_{CC}^+$ )  | 45<br>50                            | 65<br>75                                   | mA                     |
| GBP             | Gain Bandwidth Product<br>( $A_{VCL} = 100$ , $R_L = 10k\Omega$ , $C_L = 100pF$ , $f = 100kHz$ )                           |   |                                     | 1.4  | MHz                    |
| $SR^+$          | Slew Rate ( $A_{VCL} = 1$ , $R_L = 10k\Omega$ , $C_L = 100pF$ , $V_i = 2.5V$ to $7.5V$ )                                   |   |                                     | 1.3  | V/ $\mu s$             |
| $SR^-$          | Slew Rate ( $A_{VCL} = 1$ , $R_L = 10k\Omega$ , $C_L = 100pF$ , $V_i = 2.5V$ to $7.5V$ )                                   |   |                                     | 0.8  | V/ $\mu s$             |
| $\phi_m$        | Phase Margin   |   |                                     | 40   | Degrees                |
| $e_n$           | Equivalent Input Noise Voltage ( $R_s = 100\Omega$ , $f = 1kHz$ )  |   |                                     | 30   | $\frac{nV}{\sqrt{Hz}}$ |
| THD             | Total Harmonic Distortion<br>( $A_{VCL} = 1$ , $R_L = 10k\Omega$ , $C_L = 100pF$ , $V_o = 4.75V$ to $5.25V$ , $f = 1kHz$ ) |   |                                     | 0.024                                      | %                      |
| $C_{in}$        | Input Capacitance  |   |                                     | 1.5  | pF                     |
| $V_{O1}/V_{O2}$ | Channel Separation ( $f = 1kHz$ )  |   |                                     | 120  | dB                     |

**Note 1** : Maximum values including unavoidable inaccuracies of the industrial test.

TYPICAL CHARACTERISTICS

Figure 1 : Supply Current (each amplifier) versus Supply Voltage

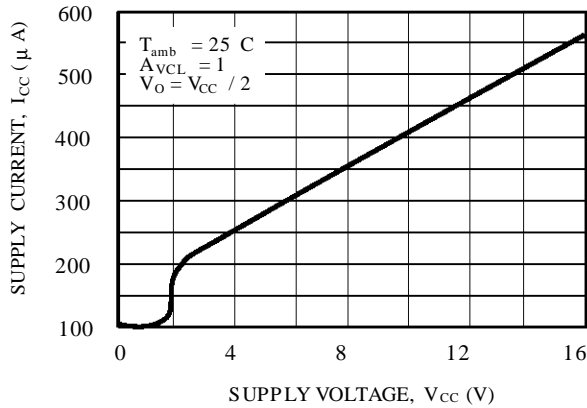

Figure 2 : Input Bias Current versus Temperature

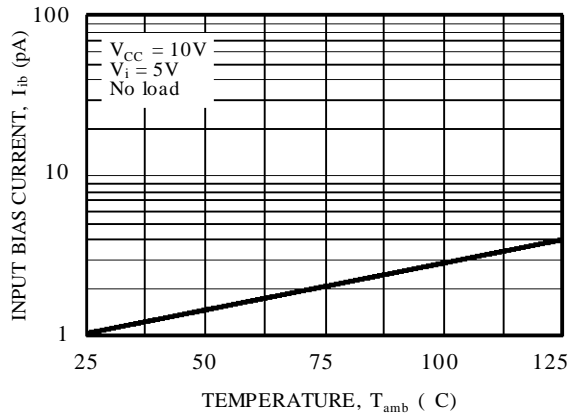

Figure 3a : High Level Output Voltage versus High Level Output Current

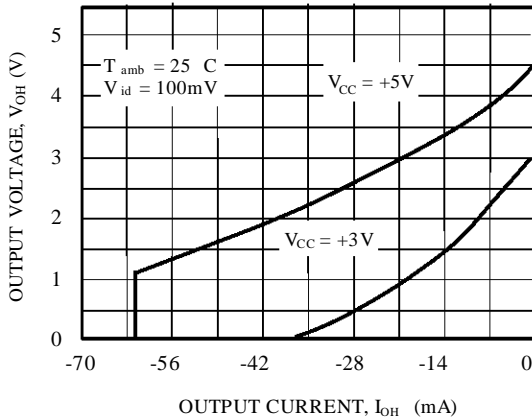

Figure 3b : High Level Output Voltage versus High Level Output Current

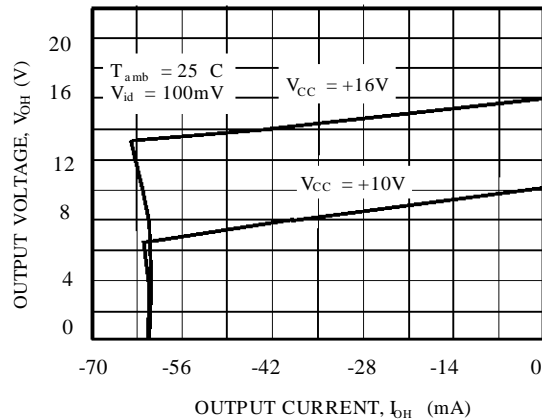

Figure 4a : Low Level Output Voltage versus Low Level Output Current

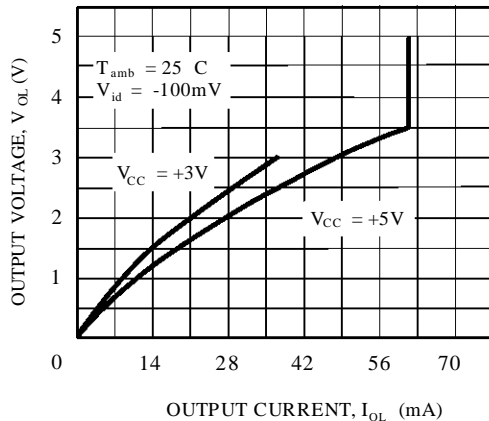
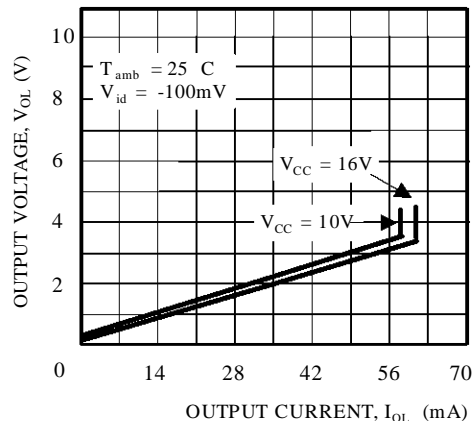
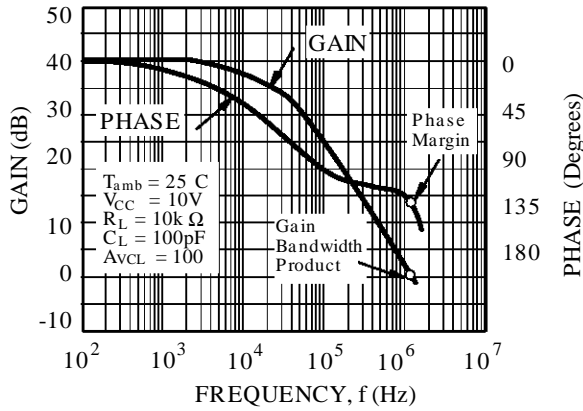

Figure 4b : Low Level Output Voltage versus Low Level Output Current



**Figure 5a** : Open Loop Frequency Response and Phase Shift



**Figure 5b** : Open Loop Frequency Response and Phase Shift

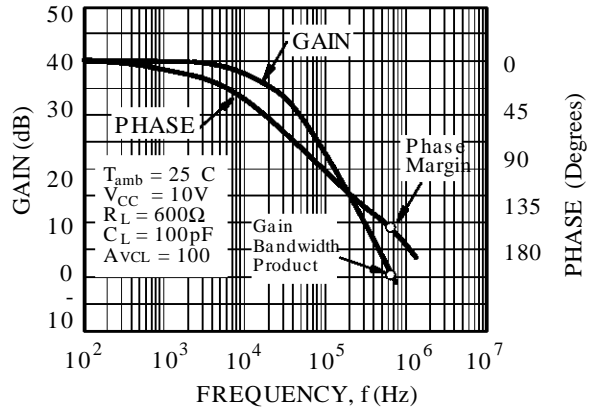

**Figure 6a** : Gain Bandwidth Product versus Supply Voltage

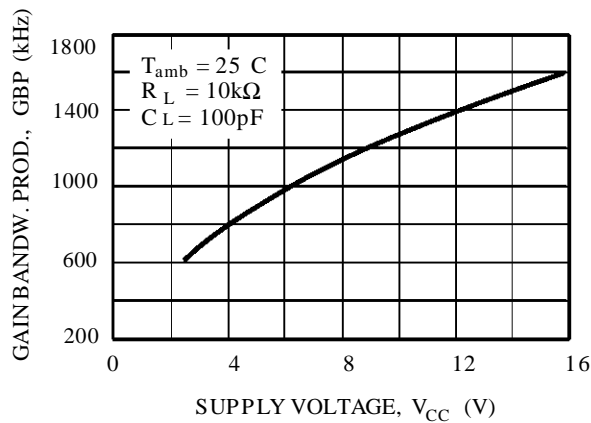

**Figure 6b** : Gain bandwidth Product versus Supply Voltage

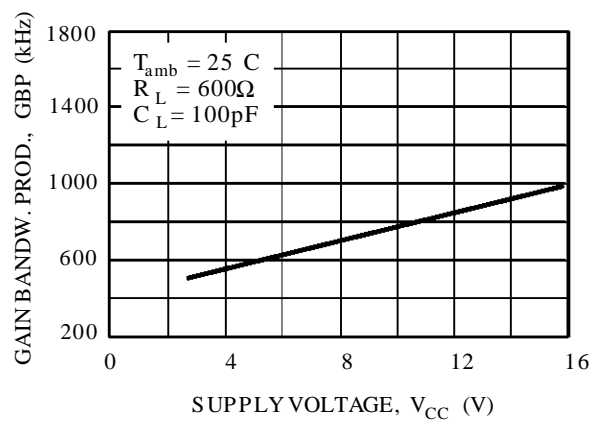

**Figure 7a** : Phase Margin versus Supply Voltage

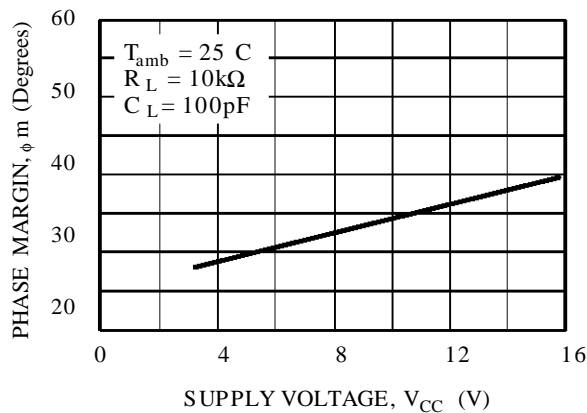

**Figure 7b** : Phase Margin versus Supply Voltage

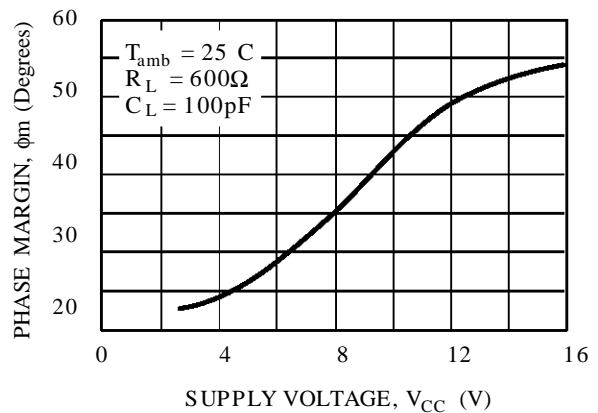
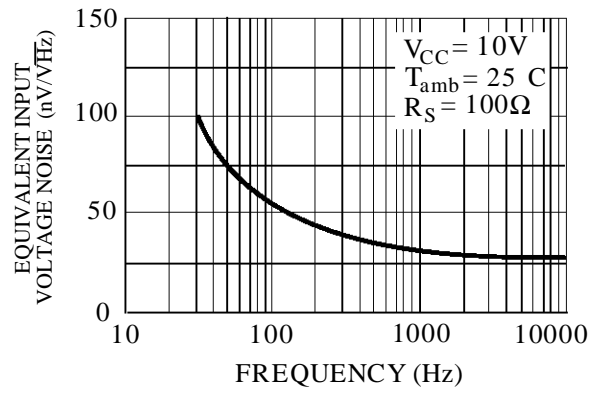
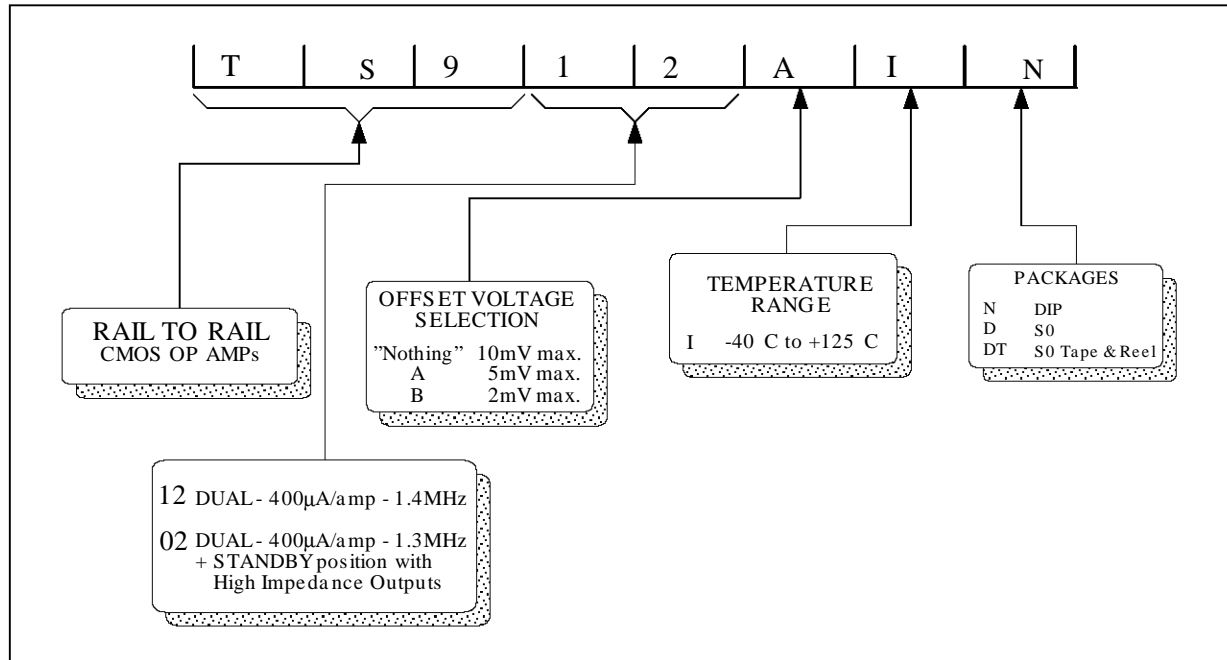

Figure 8 : Input Voltage Noise versus Frequency



ORDERING INFORMATION



**MACROMODEL**

- RAIL TO RAIL INPUT AND OUTPUT VOLTAGE RANGES
- SINGLE (OR DUAL) SUPPLY OPERATION FROM **2.7V TO 16V** ( $\pm 1.35V$  to  $\pm 8V$ )
- EXTREMELY LOW INPUT BIAS CURRENT : **1pA typ.**
- LOW INPUT OFFSET VOLTAGE : **2mV max.**
- SPECIFIED FOR **600Ω** AND **100Ω** LOADS
- LOW SUPPLY CURRENT : 400μA/Ampli
- SPEED : 1.4MHz - 1.3V/μs

**Applies to : TS912I,AI**

\*\* Standard Linear Ics Macromodels, 1993.

\*\* CONNECTIONS :

\* 1 INVERTING INPUT

\* 2 NON-INVERTING INPUT

\* 3 OUTPUT

\* 4 POSITIVE POWER SUPPLY

\* 5 NEGATIVE POWER SUPPLY

.SUBCKT TS912 1 3 2 4 5 (analog)

\*\*\*\*\*

.MODEL MDTH D IS=1E-8 KF=6.563355E-14 CJO=10F

\* INPUT STAGE

CIP 2 5 1.500000E-12

CIN 1 5 1.500000E-12

EIP 10 5 2 5 1

EIN 16 5 1 5 1

RIP 10 11 6.500000E+00

RIN 15 16 6.500000E+00

RIS 11 15 7.655100E+00

DIP 11 12 MDTH 400E-12

DIN 15 14 MDTH 400E-12

VOFP 12 13 DC 0.000000E+00

VOFN 13 14 DC 0

IPOL 13 5 4.000000E-05

CPS 11 15 3.82E-08

DINN 17 13 MDTH 400E-12

VIN 17 5 -0.5000000e+00

DINR 15 18 MDTH 400E-12

VIP 4 18 -0.5000000E+00

FCP 4 5 VOFP 7.750000E+00

FCN 5 4 VOFN 7.750000E+00

\* AMPLIFYING STAGE

FIP 5 19 VOFP 5.500000E+02

FIN 5 19 VOFN 5.500000E+02

RG1 19 5 5.087344E+05

RG2 19 4 5.087344E+05

CC 19 29 2.200000E-08

HZTP 30 29 VOFP 12.33E+02

HZTN 5 30 VOFN 12.33E+02

DOPM 19 22 MDTH 400E-12

DONM 21 19 MDTH 400E-12

HOPM 22 28 VOUT 3135

VIPM 28 4 150

HONM 21 27 VOUT 3135

VINM 5 27 150

EOUT 26 23 19 5 1

VOUT 23 5 0

ROUT 26 3 65

COUT 3 5 1.000000E-12

DOP 19 68 MDTH 400E-12

VOP 4 25 1.924

HSCP 68 25 VSCP1 1E8

DON 69 19 MDTH 400E-12

VON 24 5 2.4419107

HSCN 24 69 VSCN1 1.5E8

VSCTHP 60 61 0.1375

DSCP1 61 63 MDTH 400E-12

VSCP1 63 64 0

ISCP 64 0 1.000000E-8

DSCP2 0 64 MDTH 400E-12

DSCN2 0 74 MDTH 400E-12

ISCN 74 0 1.000000E-8

VSCN1 73 74 0

DSCN1 71 73 MDTH 400E-12

VSCTHN 71 70 -0.75

ESCP 60 0 2 1 500

ESCN 70 0 2 1 -2000

.ENDS

**ELECTRICAL CHARACTERISTICS**

$V_{CC^+} = 10V$ ,  $V_{CC^-} = 0V$ ,  $R_L, C_L$  connected to  $V_{CC}/2$ ,  $T_{amb} = 25^{\circ}C$   
(unless otherwise specified)

| Symbol       | Conditions                        | Value        | Unit       |
|--------------|-----------------------------------|--------------|------------|
| $V_{io}$     |                                   | 0            | mV         |
| $A_{vd}$     | $R_L = 10k\Omega$                 | 20           | V/mV       |
| $I_{CC}$     | No load, per operator             | 350          | $\mu A$    |
| $V_{icm}$    |                                   | -0.2 to 10.2 | V          |
| $V_{OH}$     | $R_L = 10k\Omega$                 | 9.95         | V          |
| $V_{OL}$     | $R_L = 10k\Omega$                 | 50           | mV         |
| $I_{sink}$   | $V_O = 10V$                       | 50           | mA         |
| $I_{source}$ | $V_O = 0V$                        | 50           | mA         |
| GBP          | $R_L = 10k\Omega$ , $C_L = 100pF$ | 1            | MHz        |
| SR           | $R_L = 10k\Omega$ , $C_L = 100pF$ | 1            | V/ $\mu s$ |
| $\phi_m$     | $R_L = 10k\Omega$ , $C_L = 100pF$ | 40           | Degrees    |

**PACKAGE MECHANICAL DATA**  
8 PINS - PLASTIC DIP

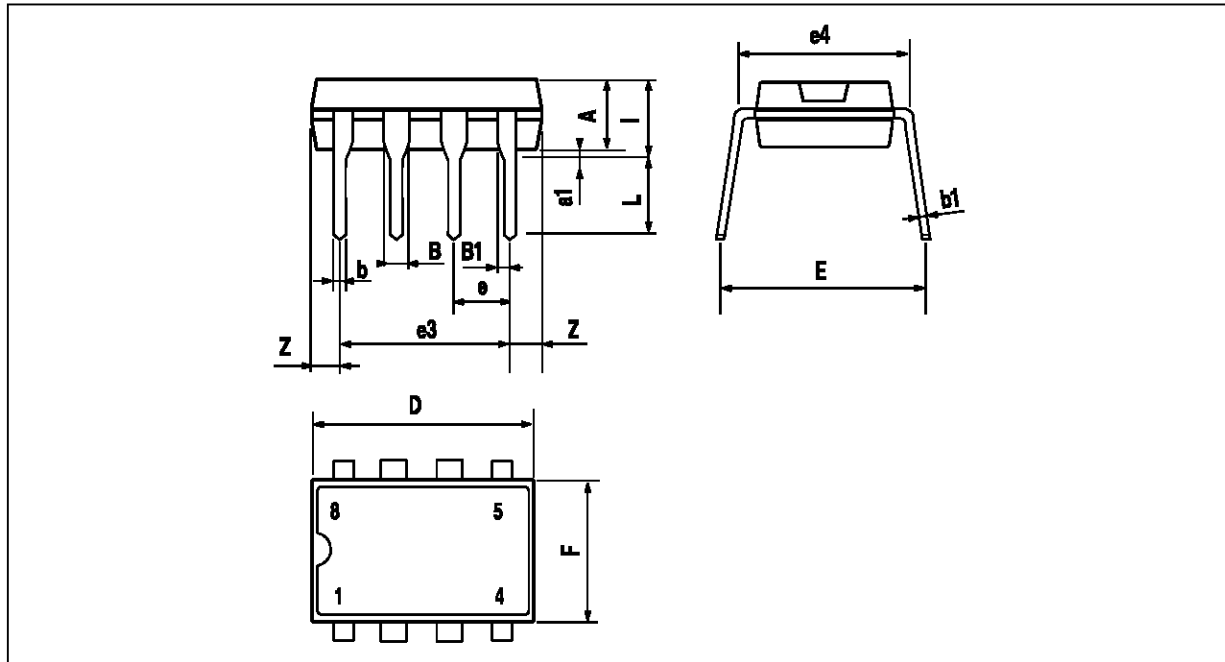

PM-DIP8.EPS

| Dimensions | Millimeters |      |       | Inches |       |       |
|------------|-------------|------|-------|--------|-------|-------|
|            | Min.        | Typ. | Max.  | Min.   | Typ.  | Max.  |
| A          |             | 3.32 |       |        | 0.131 |       |
| a1         | 0.51        |      |       | 0.020  |       |       |
| B          | 1.15        |      | 1.65  | 0.045  |       | 0.065 |
| b          | 0.356       |      | 0.55  | 0.014  |       | 0.022 |
| b1         | 0.204       |      | 0.304 | 0.008  |       | 0.012 |
| D          |             |      | 10.92 |        |       | 0.430 |
| E          | 7.95        |      | 9.75  | 0.313  |       | 0.384 |
| e          |             | 2.54 |       |        | 0.100 |       |
| e3         |             | 7.62 |       |        | 0.300 |       |
| e4         |             | 7.62 |       |        | 0.300 |       |
| F          |             |      | 6.6   |        |       | 0.260 |
| i          |             |      | 5.08  |        |       | 0.200 |
| L          | 3.18        |      | 3.81  | 0.125  |       | 0.150 |
| Z          |             |      | 1.52  |        |       | 0.060 |

DIP8.TBL

**PACKAGE MECHANICAL DATA**  
 8 PINS - PLASTIC MICROPACKAGE (SO)

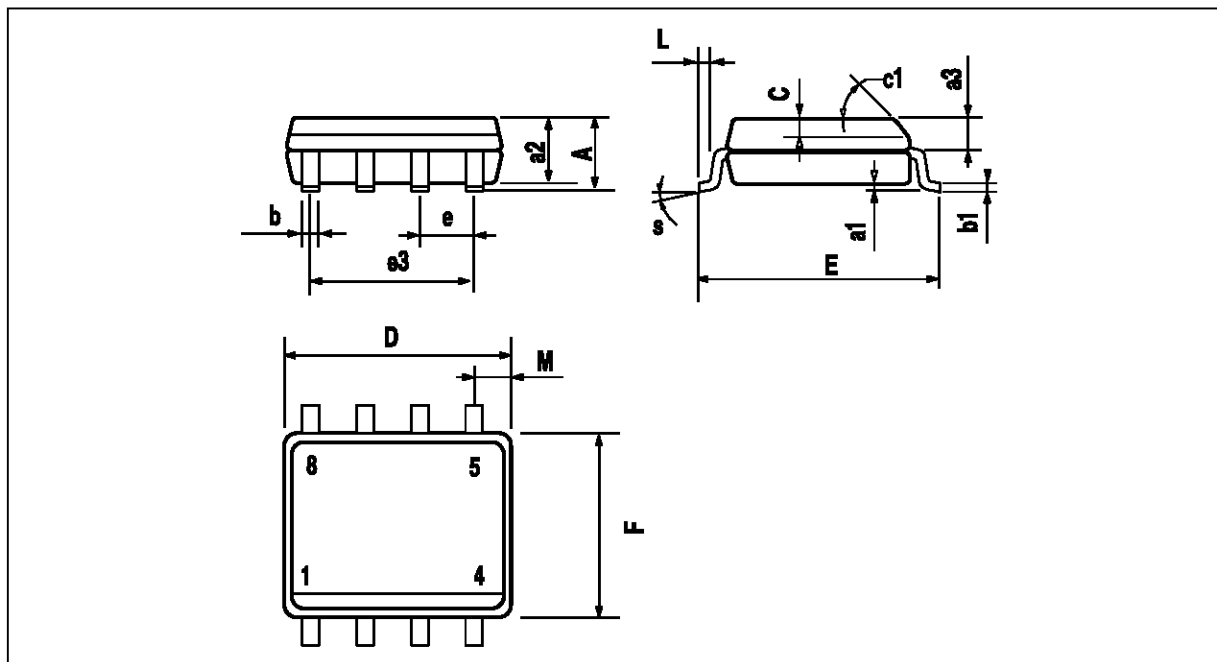

PM-S06.EPS

| Dimensions | Millimeters |      |      | Inches |       |       |
|------------|-------------|------|------|--------|-------|-------|
|            | Min.        | Typ. | Max. | Min.   | Typ.  | Max.  |
| A          |             |      | 1.75 |        |       | 0.069 |
| a1         | 0.1         |      | 0.25 | 0.004  |       | 0.010 |
| a2         |             |      | 1.65 |        |       | 0.065 |
| a3         | 0.65        |      | 0.85 | 0.026  |       | 0.033 |
| b          | 0.35        |      | 0.48 | 0.014  |       | 0.019 |
| b1         | 0.19        |      | 0.25 | 0.007  |       | 0.010 |
| C          | 0.25        |      | 0.5  | 0.010  |       | 0.020 |
| c1         | 45° (typ.)  |      |      |        |       |       |
| D          | 4.8         |      | 5.0  | 0.189  |       | 0.197 |
| E          | 5.8         |      | 6.2  | 0.228  |       | 0.244 |
| e          |             | 1.27 |      |        | 0.050 |       |
| e3         |             | 3.81 |      |        | 0.150 |       |
| F          | 3.8         |      | 4.0  | 0.150  |       | 0.157 |
| L          | 0.4         |      | 1.27 | 0.016  |       | 0.050 |
| M          |             |      | 0.6  |        |       | 0.024 |
| S          | 8° (max.)   |      |      |        |       |       |

S08.TBL

Information furnished is believed to be accurate and reliable. However, SGS-THOMSON Microelectronics assumes no responsibility for the consequences of use of such information nor for any infringement of patents or other rights of third parties which may result from its use. No license is granted by implication or otherwise under any patent or patent rights of SGS-THOMSON Microelectronics. Specification mentioned in this publication are subject to change without notice. This publication supersedes and replaces all information previously supplied. SGS-THOMSON Microelectronics products are not authorized for use as critical components in life support devices or systems without express written approval of SGS-THOMSON Microelectronics.

© 1996 SGS-THOMSON Microelectronics – Printed in Italy – All Rights Reserved

SGS-THOMSON Microelectronics GROUP OF COMPANIES  
 Australia - Brazil - Canada - China - France - Germany - Hong Kong - Italy - Japan - Korea - Malaysia - Malta - Morocco  
 The Netherlands - Singapore - Spain - Sweden - Switzerland - Taiwan - Thailand - United Kingdom - U.S.A.

ORDER CODE :