

## PROGRAMMABLE LOW POWER SINGLE OPERATIONAL AMPLIFIERS

- MICROPOWER OPERATION
- NO FREQUENCY COMPENSATION REQUIRED
- WIDE PROGRAMMING RANGE
- HIGH SLEW RATE
- SHORT-CIRCUIT PROTECTION
- PROGRAMMABLE SINGLE OP-AMPS

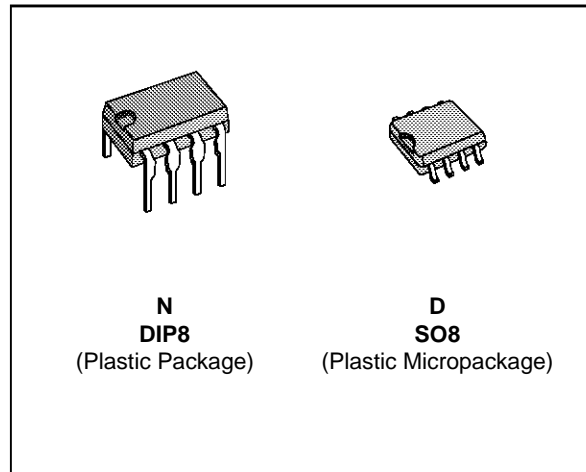

### ORDER CODES

Part Number	Temperature Range	Package	
		N	D
UA776C	0°C, +70°C	•	•
UA776I	-40°C, +105°C	•	•
UA776M	-55°C, +125°C	•	•
<b>Example : UA776CN, UA776CD</b>			

776-01.TBL

### DESCRIPTION

The UA776 programmable operational amplifier is characterized by, low supply current and low input noise over a wide range of operating supply voltages.

Coupled with programmable electrical characteristics, it is an extremely versatile amplifier for use in high accuracy, low power consumption analog applications.

Input noise voltage and current, power consumption, and input current can be optimized by a single resistor or current source that sets the chip quiescent current for nano-watt power consumption or for characteristics similar to the UA741.

Internal frequency compensation, absence of latch up, high slew rate and short-circuit protection assure ease of use in long time integrators, active filters, and sample and hold circuits.

### PIN CONNECTIONS (top view)

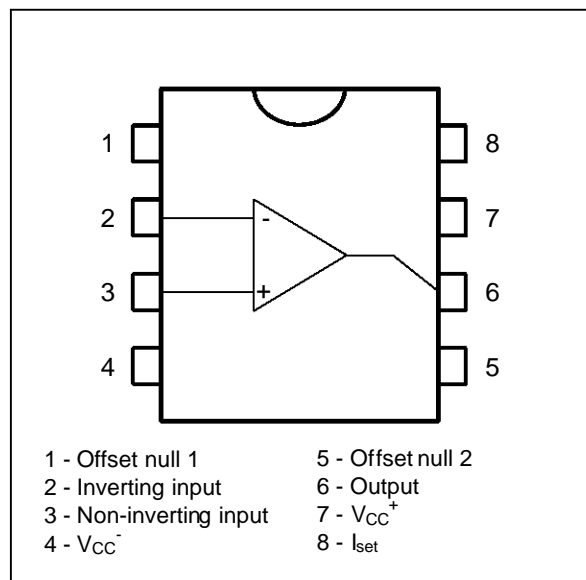

**SCHEMATIC DIAGRAM**

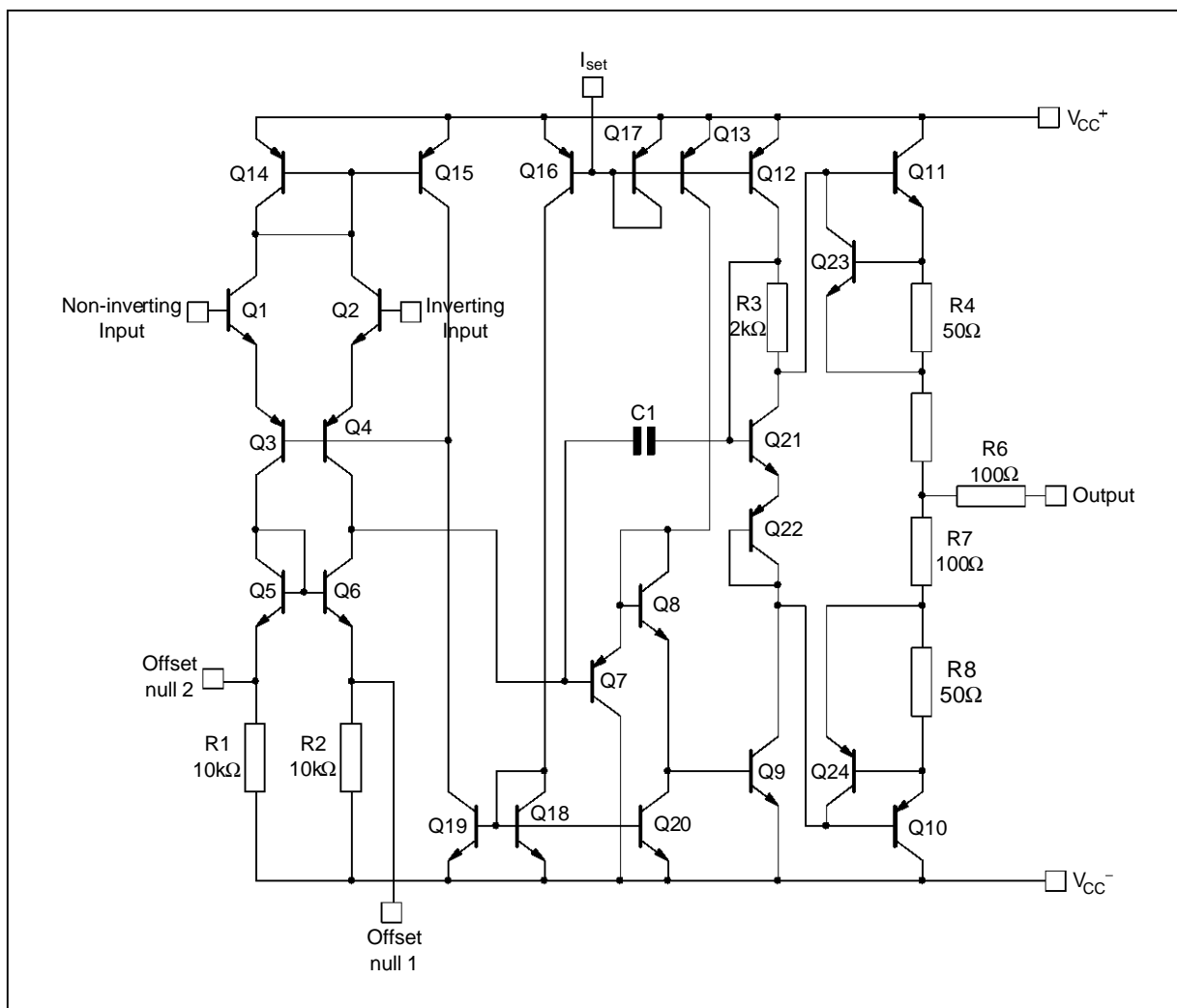

**ABSOLUTE MAXIMUM RATINGS**

Symbol	Parameter	UA776M	UA776I	UA776C	Unit
V <sub>cc</sub>	Supply Voltage	±18	±18	±18	V
V <sub>i</sub>	Input Voltage - (note 1)	±15	±15	±15	V
V <sub>id</sub>	Differential Input Voltage	±30	±30	±30	V
P <sub>tot</sub>	Power Dissipation	500	310	310	mW
	Output Short-circuit Duration	Infinite			
T <sub>oper</sub>	Operating Free Air Temperature Range	-55 to +125	-40 to +105	0 to +70	°C
T <sub>stg</sub>	Storage Temperature Range	-65 to +150	-65 to +150	-65 to +150	°C

Note : 1. For supply voltages less than ±15V, the absolute maximum input voltage is equal to the supply voltage.



**ELECTRICAL CHARACTERISTICS**

V<sub>CC</sub> = ±3V, T<sub>amb</sub> = 25°C (unless otherwise specified)

Symbol	Parameter	I <sub>set</sub> = 1.5μA			I <sub>set</sub> = 15μA			Unit
		Min.	Typ.	Max.	Min.	Typ.	Max.	
V <sub>io</sub>	Input Offset Voltage T <sub>amb</sub> = 25°C T <sub>min.</sub> ≤ T <sub>amb</sub> ≤ T <sub>max.</sub>		2	5 6		2	5 6	mV
I <sub>io</sub>	Input Offset Current T <sub>amb</sub> = 25°C T <sub>min.</sub> ≤ T <sub>amb</sub> ≤ T <sub>max.</sub>		0.7	3 10		2	15 40	nA
I <sub>ib</sub>	Input Bias Current T <sub>amb</sub> = 25°C T <sub>min.</sub> ≤ T <sub>amb</sub> ≤ T <sub>max.</sub> UA776M UA776I,C		2 2	7 10 20		15 15	50 50 100	nA
A <sub>vd</sub>	Large Signal Voltage Gain (V <sub>o</sub> = ±1V) T <sub>amb</sub> = 25°C R <sub>L</sub> = 5kΩ R <sub>L</sub> = 75kΩ T <sub>min.</sub> ≤ T <sub>amb</sub> ≤ T <sub>max.</sub> R <sub>L</sub> = 5kΩ R <sub>L</sub> = 75kΩ	50 25	200		50 25	200		V/mV
SVR	Supply Voltage Rejection Ratio (R <sub>s</sub> ≤ 10kΩ) T <sub>amb</sub> = 25°C T <sub>min.</sub> ≤ T <sub>amb</sub> ≤ T <sub>max.</sub>	77 77	92		77 77	92		dB
I <sub>CC</sub>	Supply Current, no load T <sub>amb</sub> = 25°C T <sub>min.</sub> ≤ T <sub>amb</sub> ≤ T <sub>max.</sub>		13	20 25		130	160 180	μA
V <sub>icm</sub>	Input Common Mode Voltage Range	±1			±1			V
CMR	Common Mode Rejection Ratio (R <sub>s</sub> ≤ 10kΩ) T <sub>amb</sub> = 25°C T <sub>min.</sub> ≤ T <sub>amb</sub> ≤ T <sub>max.</sub>	70 70	90		70 70	90		dB
I <sub>os</sub>	Output Short-circuit Current	0.5	3	15	2	5	20	mA
±V <sub>OPP</sub>	Output Voltage Swing T <sub>amb</sub> = 25°C T <sub>min.</sub> ≤ T <sub>amb</sub> ≤ T <sub>max.</sub> R <sub>L</sub> = 75kΩ R <sub>L</sub> = 5kΩ R <sub>L</sub> = 75kΩ R <sub>L</sub> = 5kΩ	2 2	2.4		2 1.9 2 1.9	2.4 2.1		V
V <sub>ior</sub>	Offset Voltage Adjustment Range		9			18		mV
SR	Slew Rate (V <sub>i</sub> = ±1V, C <sub>L</sub> = 100pF, unity gain) R <sub>L</sub> = 5kΩ R <sub>L</sub> = 75kΩ		0.03			0.35		V/μs
t <sub>r</sub>	Rise Time (V <sub>i</sub> = ±20mV, C <sub>L</sub> = 100pF, unity gain) R <sub>L</sub> = 5kΩ R <sub>L</sub> = 75kΩ		3			0.6		μs
K <sub>ov</sub>	Overshoot (V <sub>i</sub> = ±20mV, C <sub>L</sub> = 100pF, unity gain) R <sub>L</sub> = 5kΩ R <sub>L</sub> = 75kΩ		0			5		%
R <sub>i</sub>	Input Resistance		50			5		MΩ
C <sub>id</sub>	Differential Input Capacitance		2			2		pF
R <sub>o</sub>	Output Resistance		5			1		kΩ
GBP	Gain Bandwidth Product (T <sub>amb</sub> = 25°C, C <sub>L</sub> = 100pF) f = 100kHz f = 10kHz R <sub>L</sub> = 5kΩ R <sub>L</sub> = 75kΩ		0.075			0.5		MHz
THD	Total Harmonic Distortion (f = 1kHz, A <sub>v</sub> = 20dB, V <sub>o</sub> = 1V <sub>PP</sub> , C <sub>L</sub> = 100pF, T <sub>amb</sub> = 25°C) R <sub>L</sub> = 5kΩ R <sub>L</sub> = 75kΩ		1			0.03		%
e <sub>n</sub>	Equivalent Input Noise Voltage (f = 1kHz, R <sub>s</sub> = 100Ω)		20			20		$\frac{nV}{\sqrt{Hz}}$

776-04.TBL

**BIASING CIRCUITS**

**RESISTOR BIASING**

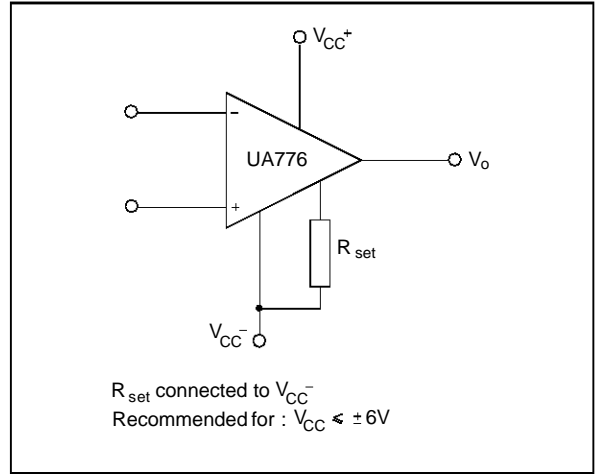
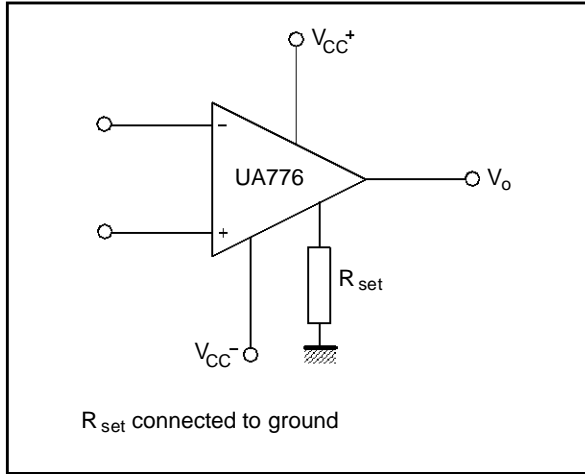

**TRANSISTOR CURRENT SOURCE BIASING**

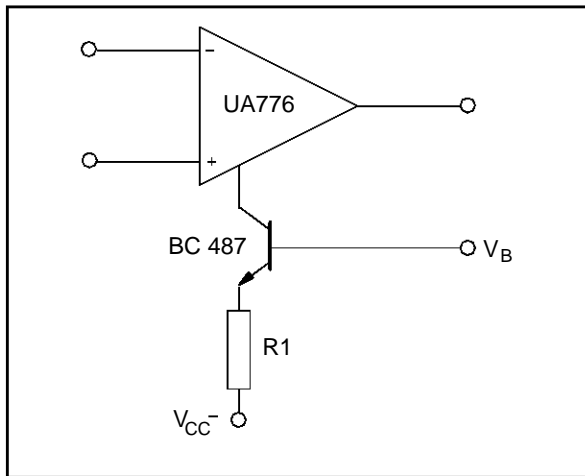

**FET CURRENT SOURCE BIASING**

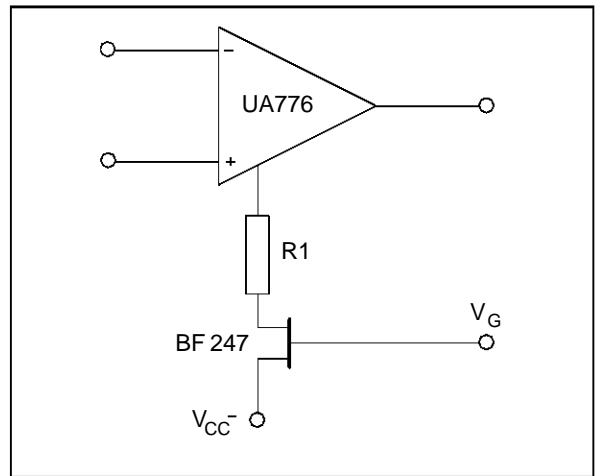

**OFFSET VOLTAGE NULL CIRCUIT**

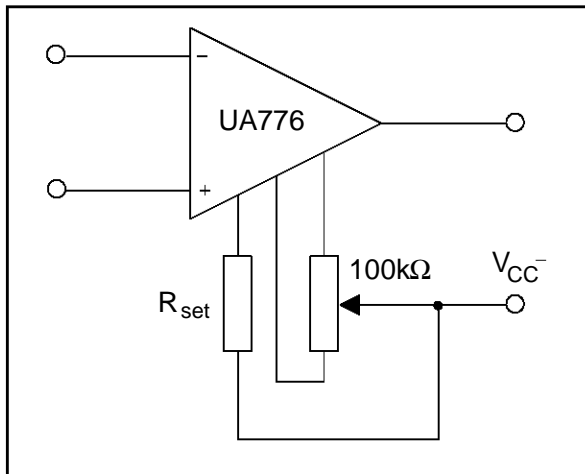

**TRANSIENT RESPONSE TIME TEST CIRCUIT**

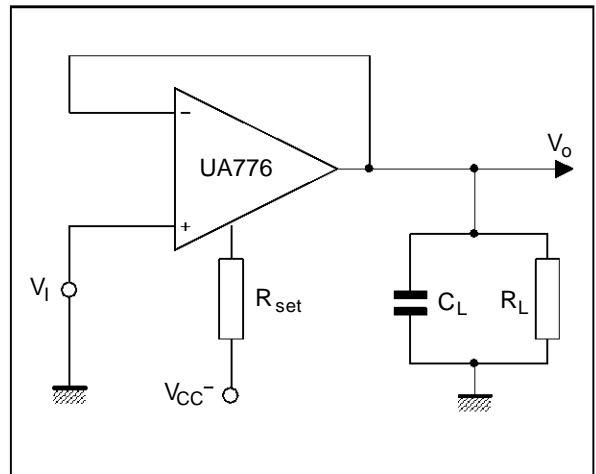

TYPICAL APPLICATIONS

HIGH ACCURACY SAMPLE AND HOLD

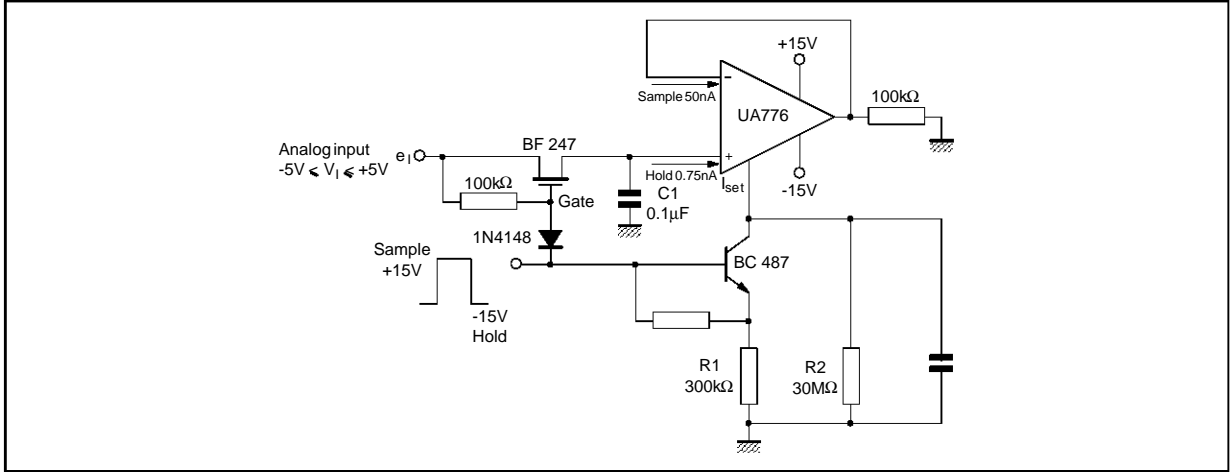

776-10.EPS

MULTIPLEXING AND SIGNAL CONDITIONING WITHOUT FETs

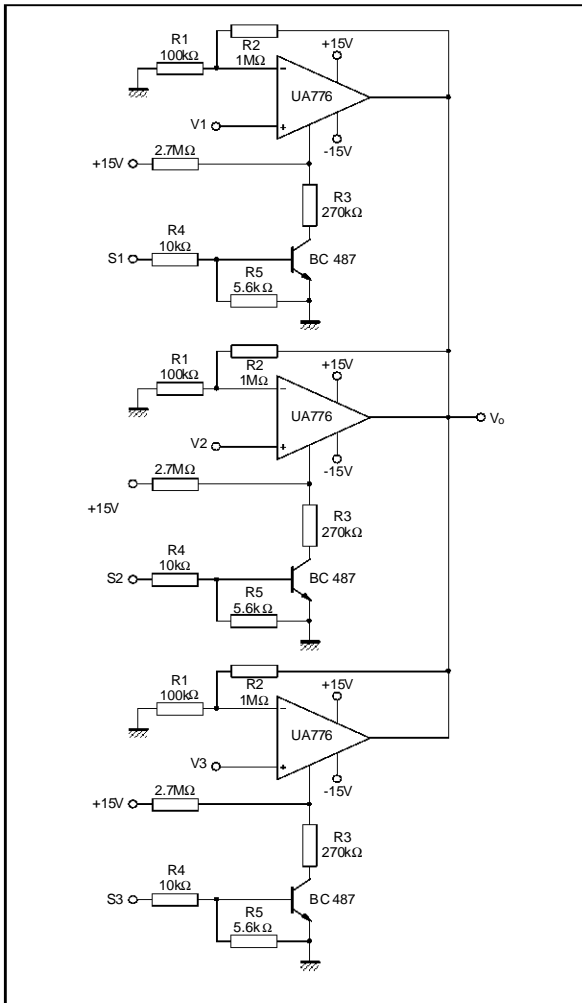

776-11.EPS

NANO-WATT AMPLIFIER

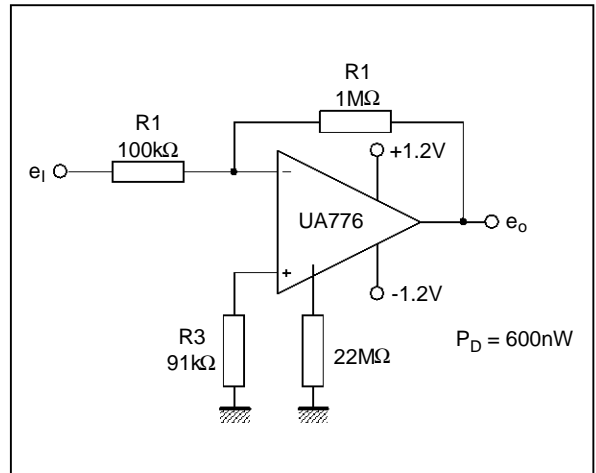

776-12.EPS

HIGH INPUT IMPEDANCE AMPLIFIER

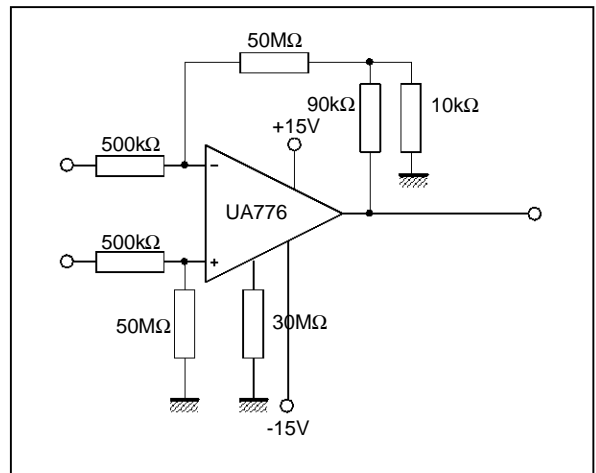

776-13.EPS

**PACKAGE MECHANICAL DATA**  
8 PINS - PLASTIC DIP

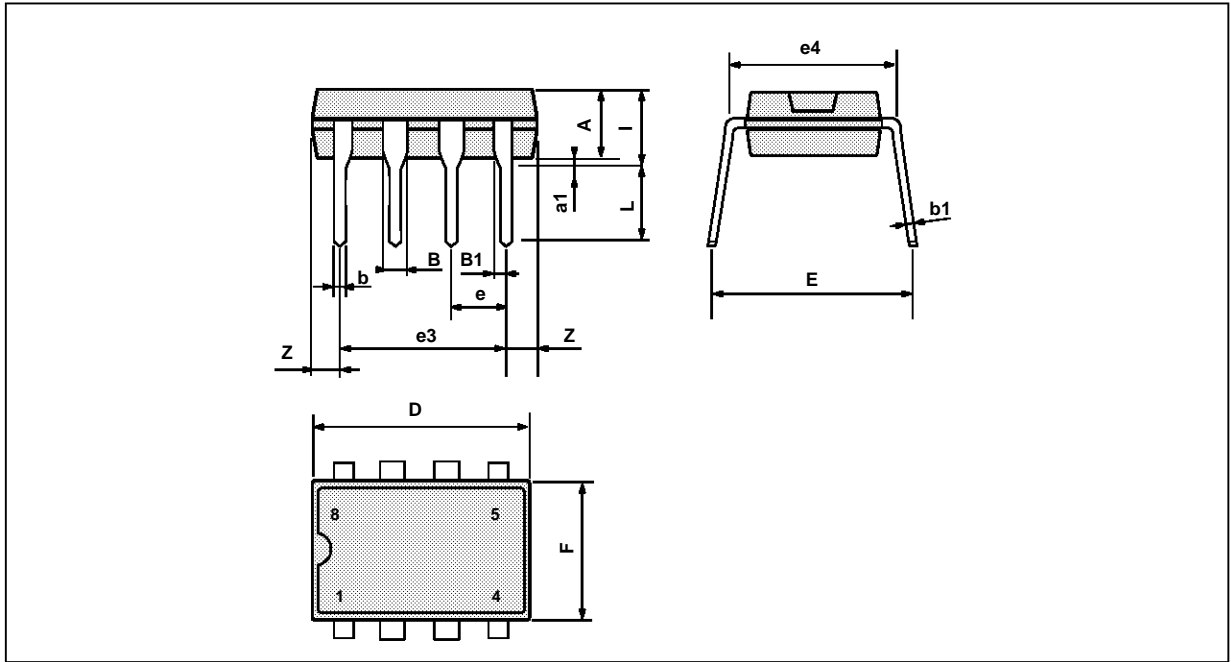

PM-DIP8.EPS

Dimensions	Millimeters			Inches		
	Min.	Typ.	Max.	Min.	Typ.	Max.
A		3.32			0.131	
a1	0.51			0.020		
B	1.15		1.65	0.045		0.065
b	0.356		0.55	0.014		0.022
b1	0.204		0.304	0.008		0.012
D			10.92			0.430
E	7.95		9.75	0.313		0.384
e		2.54			0.100	
e3		7.62			0.300	
e4		7.62			0.300	
F			6.6			0.260
i			5.08			0.200
L	3.18		3.81	0.125		0.150
Z			1.52			0.060

DIP8.TBL

**PACKAGE MECHANICAL DATA**  
8 PINS - PLASTIC MICROPACKAGE (SO)

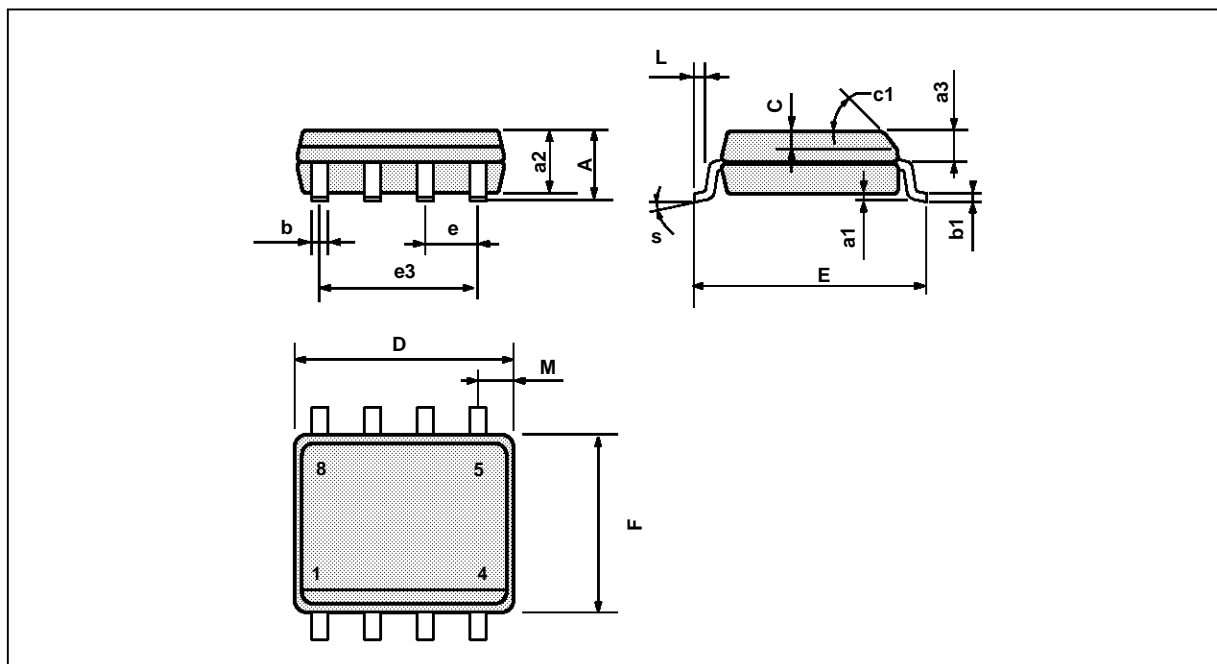

PM-SO8.EPS

Dimensions	Millimeters			Inches		
	Min.	Typ.	Max.	Min.	Typ.	Max.
A			1.75			0.069
a1	0.1		0.25	0.004		0.010
a2			1.65			0.065
a3	0.65		0.85	0.026		0.033
b	0.35		0.48	0.014		0.019
b1	0.19		0.25	0.007		0.010
C	0.25		0.5	0.010		0.020
c1	45° (typ.)					
D	4.8		5.0	0.189		0.197
E	5.8		6.2	0.228		0.244
e		1.27			0.050	
e3		3.81			0.150	
F	3.8		4.0	0.150		0.157
L	0.4		1.27	0.016		0.050
M			0.6			0.024
S	8° (max.)					

SO8.TBL

Information furnished is believed to be accurate and reliable. However, SGS-THOMSON Microelectronics assumes no responsibility for the consequences of use of such information nor for any infringement of patents or other rights of third parties which may result from its use. No licence is granted by implication or otherwise under any patent or patent rights of SGS-THOMSON Microelectronics. Specifications mentioned in this publication are subject to change without notice. This publication supersedes and replaces all information previously supplied. SGS-THOMSON Microelectronics products are not authorized for use as critical components in life support devices or systems without express written approval of SGS-THOMSON Microelectronics.

© 1995 SGS-THOMSON Microelectronics - All Rights Reserved

SGS-THOMSON Microelectronics GROUP OF COMPANIES

Australia - Brazil - France - Germany - Hong Kong - Italy - Japan - Korea - Malaysia - Malta - Morocco - The Netherlands  
Singapore - Spain - Sweden - Switzerland - Taiwan - Thailand - United Kingdom - U.S.A.

ORDER CODE :